

smooth. good. advised.



## SOLUTIONS IN PLASTICS

CUSTOM FINISHED PRODUCTS | SEMI-FINISHED PRODUCTS | CHAIN GUIDES | CHAIN TENSIONERS



## PRINT UPDATE

For up-to-date information about the available Murtfeldt print products, see: [murtfeldt.com/services/print-media-updates](https://murtfeldt.com/services/print-media-updates)

Here, you can check online at all times to see whether there have been any changes to existing Murtfeldt catalogues, brochures and calendars.





# INNOVATION AND TRADITION

Murtfeldt paved the way for success more than 60 years ago when Original Material "S"<sup>®</sup> green was introduced. Today, this brand remains synonymous with excellent slide properties, high abrasion and wear resistance, and a long lifetime.

Although Murtfeldt started life as merely a trading partner, it soon established itself as a competent contact partner for the production of individual components and began advising customers and designing and developing its own plastics. At present, Murtfeldt uses both machining techniques and 3D printing. The chosen production method is based on individual consulting, whereby Murtfeldt's design engineers cost the machining possibilities and plastics before formulating their recommendation.

One thing always remains unchanged: Customers see us as a reliable partner for all industrial plastic applications. Furthermore, they connect the name Murtfeldt with terms such as reliability, security, commitment, and friendliness. These are values that play a major role for us – both now and in the future.



## MURTFELDT – THE COMPANY

# 1

5 – 14

Murtfeldt – innovation and tradition :: Impressions of Murtfeldt :: Local to you – across Europe



## PLASTICS

# 2

15 – 48

General :: Food safe [FS] plastics :: Material "S"<sup>®</sup> group :: Technical plastics :: High-performance plastics



## INDIVIDUAL SOLUTIONS

# 3

49 – 62

Jointly designed :: Murtfeldt machinery :: 3D-printing :: Plastic conveyor screws :: Cog wheels :: Product turners :: Ram protection :: Quality management :: Environmental & energy management



## CHAIN, BELT AND SLIDING GUIDES

# 4

63 – 112

General :: Chain guides :: Belt guides :: Chain racks :: Special profiles :: Accessories



## TENSIONING SYSTEMS

# 5

113 – 148

Function, principles, handling :: Chain tensioners :: Belt tensioners :: Fastening brackets :: Special tensioners



## TECHNICAL INFORMATION

# 6

149 – 172

Sheet dimensions :: Rod dimensions :: Plastic characteristics :: Plastics compared :: Information on the behaviour of plastics





# MURTFELDT – THE COMPANY



## MURTFELDT – 15 GOOD REASONS

■ More than 60 years of experience, growth, and innovation

---

■ The highest quality standards and optimum quality management

---

■ A consolidated, area-wide national network of advisers

---

■ Representatives throughout Europe and the world

---

■ Consulting services and project supervision in technical application and design

---

■ All consulting services are free and non-binding and are provided by permanent points of contact in Germany and worldwide

---

■ Quick and flexible delivery of standard parts – within 24 hours on request

---

■ Custom manufacturing from drawings

---

■ The latest production plants for machining and 3D printing

---

■ Help with material selection

---

■ Material analysis and development in Murtfeldt's own laboratories

---

■ Smooth multi-shift production

---

■ Short response and reaction times

---

■ The status of orders can be queried at any time, thus providing maximum transparency

---

■ Environmentally aware thinking and trade

# MURTFELDT IMPRESSIONS



MURTFELDT - THE COMPANY









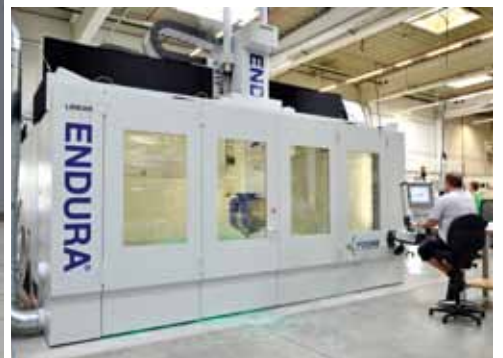
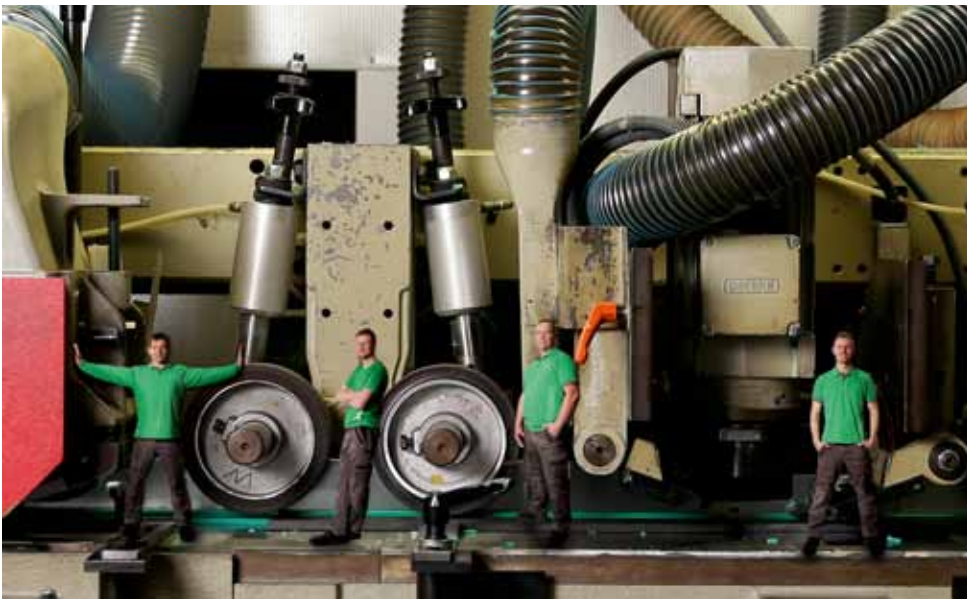









OUR WORLD IS GREEN!

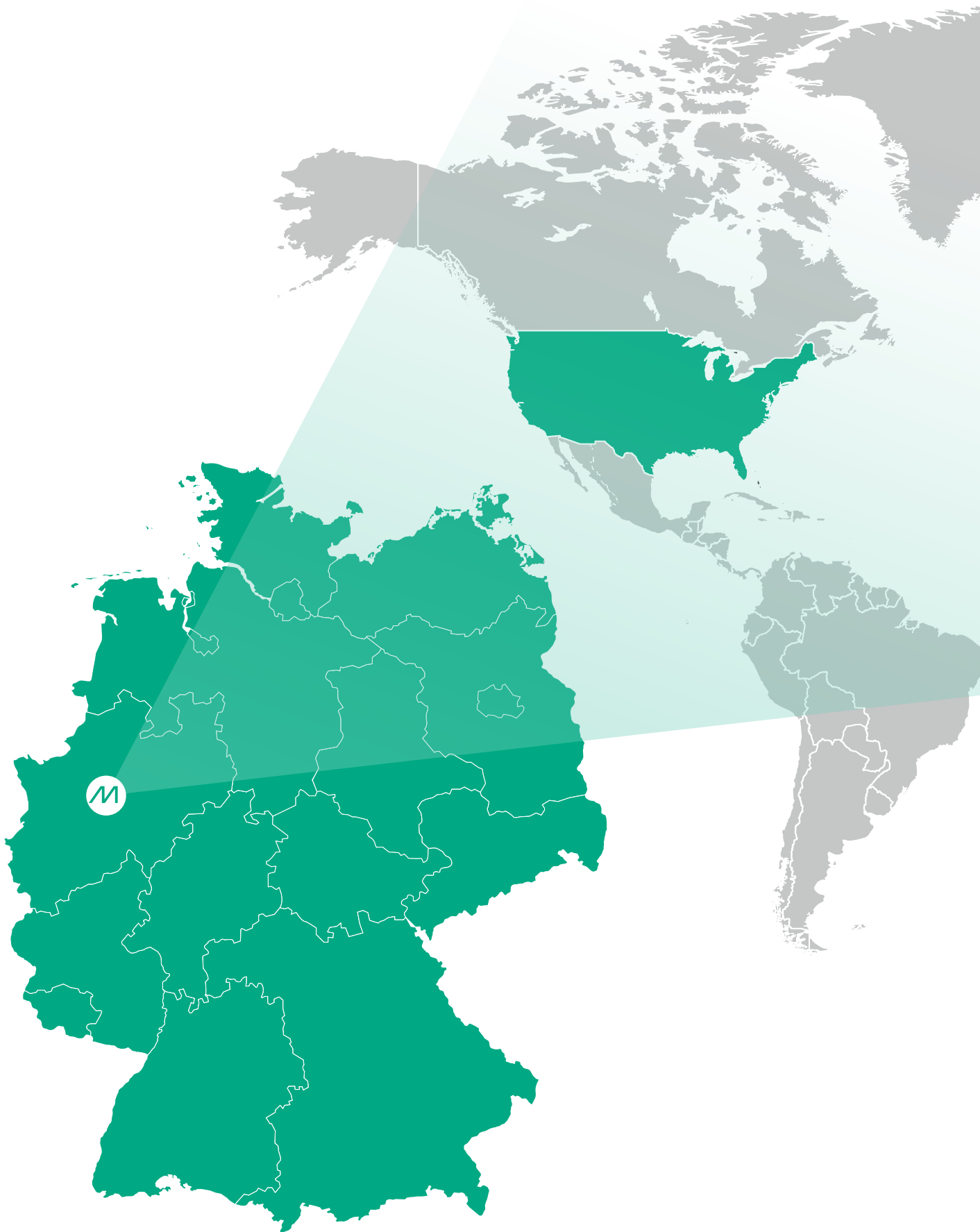

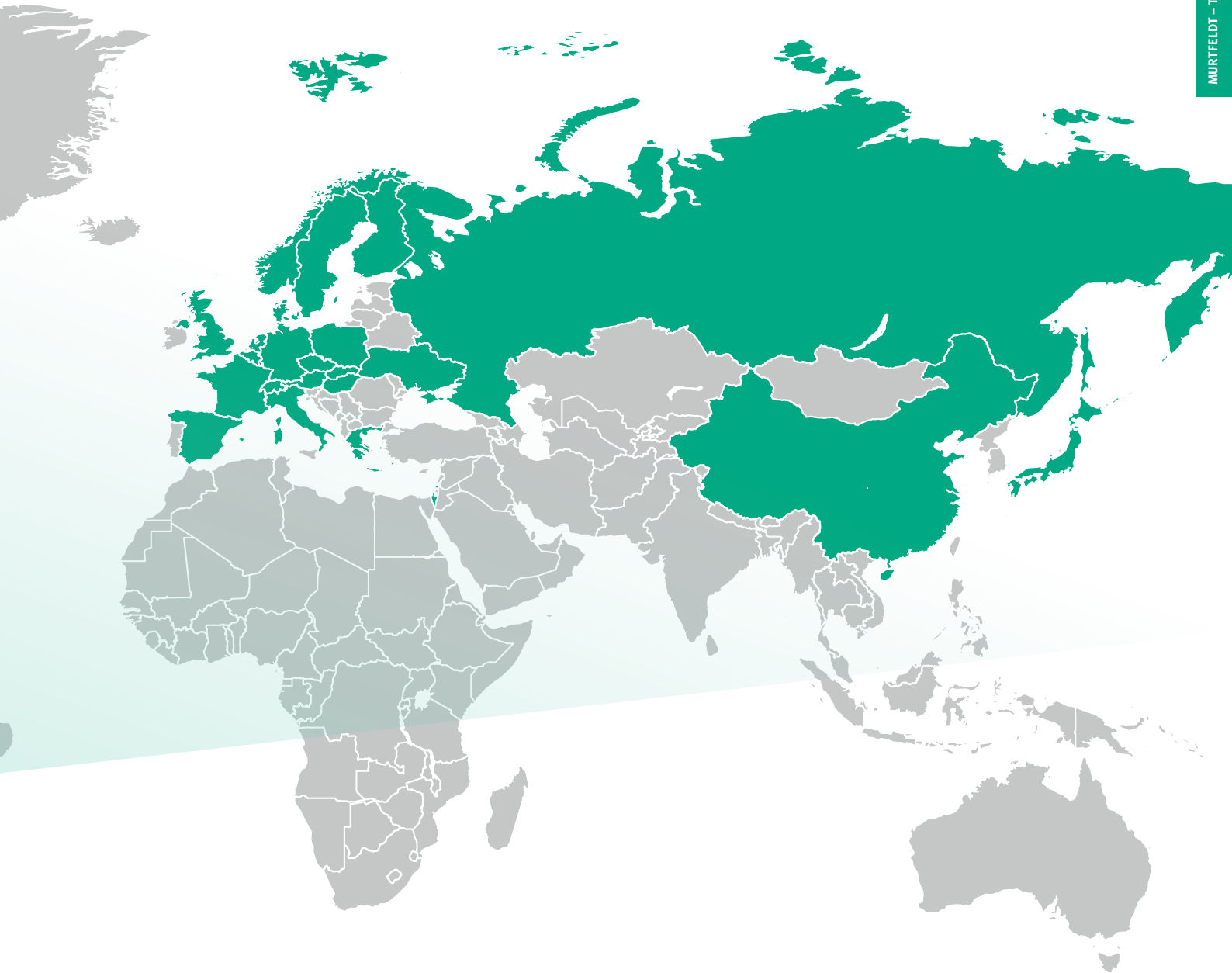

Just three clicks to the contact you need:  
At [murtfeldt.de/en/contact-us](https://murtfeldt.de/en/contact-us) you'll find the contact partner you need at home and abroad.  
**Give us a try – we'll be happy to provide all the advice you need!**









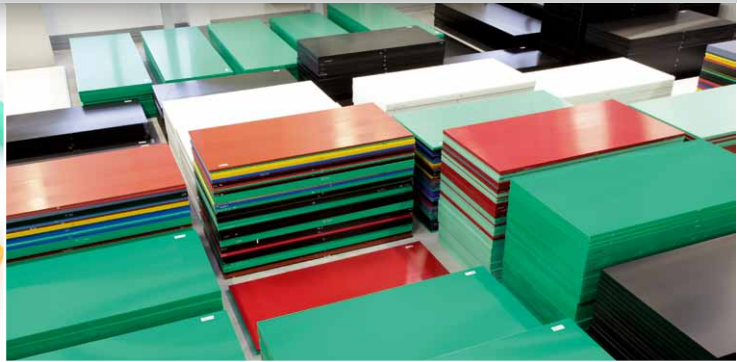























# PLASTICS



# PLASTICS – TABLE OF CONTENTS

Introduction	17
Food Safe Plastics	18 – 21
Material "S" <sup>®</sup> Group	22 – 35
Original Material "S" <sup>®</sup> green  / Original Material "S" <sup>®</sup> natural 	22
Original Material "S" <sup>®</sup> black 	23
Material "S" <sup>®</sup> 1000	24
Muralen <sup>®</sup>  / Muralen <sup>®</sup> black  / Muralen <sup>®</sup> plus + AB 	25
Original Material "S" plus + <sup>®</sup> ESD 	26
Original Material "S" plus + <sup>®</sup> LF 	27
Original Material "S" plus + <sup>®</sup> LF ESD 	28
Original Material "S" plus + <sup>®</sup> LFP ESD  	29
Material "S" <sup>®</sup> 8000 <sup>®</sup>	30
Original Material "S" plus + <sup>®</sup> Bright ESD	31
Original Material "S" plus + <sup>®</sup> AB 	32
Original Material "S" plus + <sup>®</sup> FP [FS] <sup>®</sup> 	33
Original Material "S" plus + <sup>®</sup> GB 	34
Original Material "S" plus + <sup>®</sup> TLS 	35
Technical Plastics	36 – 42
Murlubric <sup>®</sup> / Murlubric <sup>®</sup> blue [FS] <sup>®</sup> 	36
Murylon <sup>®</sup> B  / Murylon <sup>®</sup> A 	37
Murylon <sup>®</sup> AGF / Murylon <sup>®</sup> 6 Cast	38
Murdopol <sup>®</sup>	39
Murytal <sup>®</sup> C / MurytalC natural [FS] <sup>®</sup>  / MurytalC blue [FS] <sup>®</sup> 	40
Murytal <sup>®</sup> H / Murytal <sup>®</sup> ESD	41
Murylat <sup>®</sup>  / Murylat <sup>®</sup> SP 	42
„High-Performance“ Plastics	43 – 48
Murylon <sup>®</sup> HT	43
Murinyl <sup>®</sup> 	44
Murflor <sup>®</sup> 	45
Murflor <sup>®</sup> + Carbon / Murflor <sup>®</sup> + Bronze / Murflor <sup>®</sup> + Glass	46
Murinit <sup>®</sup> SP 	47
Murpec <sup>®</sup>  / Murpec <sup>®</sup> SP	48

# PLASTICS

## The best material for every application

Our range constitutes the basis for optimized machining and production processes and includes specially designed materials that are carefully tuned for use in an extremely wide range of applications.

### The most important factors of our materials' success

- Excellent slide properties
- High wear resistance
- Great mechanical and chemical resistance
- Long lifetime

### Our service

- Pre-cut custom parts from sheets and rods
- Individual solutions
- Large warehouse stock of semi-finished parts with different dimensions
- Short delivery times thanks to ample warehouse capacities



**Plastics for use in the food industry ::** EC Regulation 10/2011, which has been in force since 2011, currently forms part of EC Regulation 1935/2004. It stipulates rules for dealing with materials and items made from plastic and intended to come into contact with foods. Murtfeldt has certified its relevant plastics and now indicates materials which are suitable for contact with foods using the letters [FS] „Food Safe“.

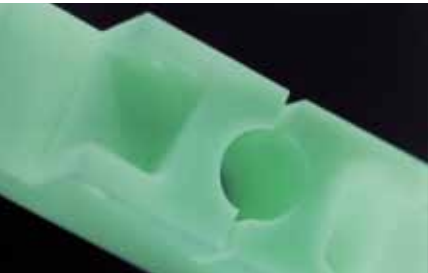

**Group "S"® Plastics ::** This Murtfeldt group of plastics was developed on the basis of the tried-and-tested Original Material "S"® green. These materials are made from high-quality UHMW polyethylene. They boast properties that have been specifically adjusted for various application areas.



**Technical Plastics ::** Each sector and application has specific requirements for machines and plants. Quality is important in even the smallest components, since it influences subsequent production and machining processes. We have always concentrated on the task of developing forward-looking products for a wide application spectrum. Our technical materials are primarily characterized by good slide properties and high wear resistance. This means that we are able to guarantee a long lifetime for our materials and low maintenance requirements for your plants.



**High-Performance Plastics ::** Our high-performance materials are designed to meet unusual requirements and high stresses and stains. They are the result of the consistent development of our technical materials. They are characterized by exceptional chemical, mechanical, and thermal resistance and resilience in situations of dynamic stress. Murtfeldt high-performance materials are therefore ideally suited for extremely customized tasks.

# FOOD SAFE PRODUCTS

## FOOD SAFE [FS]

### REGULATION (EC) NO. 1935/2004

#### What's allowed in food products?

Plasticisers in olive oil or pesto sauces, heavy metals from ceramic glazes, and ink components in drinks: Unappetising or even unhealthy examples of food impurities that really make consumers see red. But in fact, there are justifiable and functional reasons why foods come into contact with certain substances. This might be during production with special machines, during filling, whilst being transported in designated containers, during storage, or whilst being delivered.

**Nevertheless:** There are risks involved in the interaction of foods and impurities, and these risks must be kept to a minimum. Since 2004, Regulation (EC) No. 1935/2004 – which is still in force today – has governed these risks. Its most important relevant statement here: Raw materials and items must be manufactured in a way that ensures that – in normal, foreseeable usage conditions – their components only pass into foods in levels that cannot endanger the health of the consumer.



### REGULATION (EU) NO. 10/2011

#### New requirements for manufacturers of plastics

In January 2011, the European Commission adopted a new regulation on materials and items made from plastic and intended to come into contact with foods. This new regulation – Regulation (EU) No. 10/2011 – is in force since the 1st of May 2011 and forms part of Regulation (EC) No. 1935/2004.

#### Its most important content?

---

A list of source materials (monomers) and a list of auxiliary materials (additives) that can be used to manufacture plastics

---

Migration processes based on limit values and purity specifications

---

Conformity declarations

---

Batch tracking

---

Manufacturing as per Regulation (EC) No. 2023/2006 (Good Manufacturing Practice)

---



## WHAT IS THE MEANING OF... EU CONFORMITY?

It is confirmed by the manufacturer/entity placing materials on the market in accordance with Regulation (EU) No. 10/2011.

Constituent substances must comply with the Union List as set out in the regulation.

Specific and global migration must be tested on the finished product by an independent, accredited laboratory.

Traceability must be assured at every stage.

It is compulsory within the EU.

## FDA CONFORMITY?

It is confirmed in accordance with Title 21 of the Code of Federal Regulations (CFR) issued by the U.S. Food and Drug Administration (FDA).

The recipe/constituent substances are deemed and confirmed as individual substances in accordance with the Positive List.

It is compulsory within the United States of America.

## LET'S GET DOWN TO THE NITTY-GRITTY!

### Which source materials and additives can be used?

The substance lists for monomers and additives contain more than 900 source materials that are approved at EU level. Only these substances may be used to manufacture materials and plastic products in accordance with their specific migration values.

### What happens in the "migration process"?

For plastics, there are substance-specific limit values for the transition of these substances to foods. These are called "migration values". These values are determined by means of migration tests that are carried out by independent institutions. If the result of a migration process is successful, the manufacturer is entitled to issue the required certificate of conformity for the outgoing goods.

A declaration of conformity is valid until changes are made to the composition of the material or to the production process that consequently alter the migration of substances from the material or plastic product or until new scientific knowledge is available. The migration process consists of two tests:

Part of the migration process is the overall migration limit test (OML) and the specific migration limit test (SML). In the case of the overall migration limit, the total of all migrating substances may not exceed 60 ppm. The specific migration test determines specific migration values for individual monomers and additives cited in the regulation on plastics.

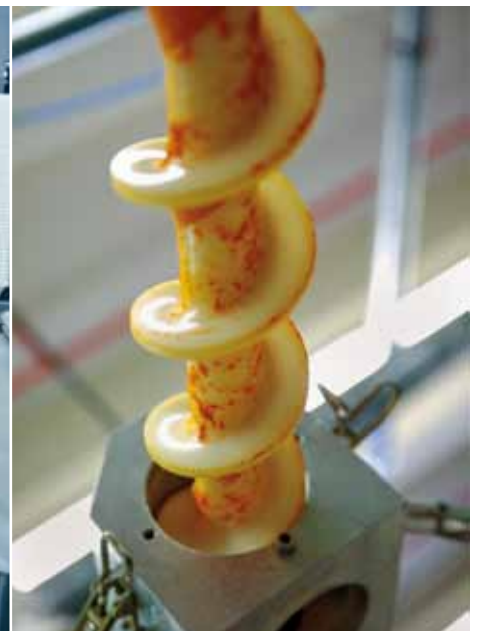



# FOOD SAFE PRODUCTS

## FOOD SAFE [FS]

### THE DECLARATION OF CONFORMITY

In accordance with the stipulations of the new EU regulation, each manufacturer or importer of commodities that are made from plastics and that come into contact with foods must enclose a written declaration of conformity with each product.

The main aim of this declaration of conformity is to enable the easy identification and thus traceability of the used materials for which it is issued. It should ensure that there is sufficient information on the substances used and their decomposition products over the entire supply chain as well as information on the use of the material.

### THE TRACEABILITY

**In other words: Where did the plastic come from?  
And where is it going to?**

The following was mentioned already in the section on the declaration of conformity: Traceability. This refers to the mandatory requirement to identify an item and enable the tracing of its manufacturing, processing, and sales stages. In each case, at least one prior and one subsequent stage must be identifiable. This is achieved by labelling the plastic and placing information on the manufacturer, date of production, production process etc. on the label.

### GOOD MANUFACTURING PRACTICE (GMP)

#### Quality management

Good Manufacturing Practice (GMP) – which means ensuring good production by means of quality assurance – emanates from Regulation (EC) No. 2023/2006, which is embedded in Regulation (EC) No. 1935/2004. According to this concept, manufacturing is a part of a quality system that ensures the safe and traceable production of products in the pharmaceutical and food industries. In practice, an ISO quality system that is already in place must be supplemented by the GMP directives.



The pages above have made one thing clear: The new regulation requires companies to make a high investment in time, employee know-how, and capital. Murtfeldt Plastics has risen up to meet these challenges, and was able to conclude the

required migration processes for its products that are intended for use in the food industry. The below mentioned plastic are approved for use according to the EU regulation as well as FDA regulation.

---

**Overview of Murtfeldt PE plastics that are approved for use in the food industry as per Regulation (EC) No. 1935/2004 and Regulation (EU) No. 10/2011**

---

**Original Material "S"® green [FS]®**  
Production based on PE-UHMW SG 1.2

---

**Original Material "S"® natural [FS]®**  
Production based on PE-UHMW SG 1.2

---

**Original Material "S"® black [FS]®**  
Production based on PE-UHMW SG 1.2

---

**Original Material "S" plus +® FP [FS]® (sky-blue)**  
Production based on PE-UHMW SG 1.1

---

**Original Material "S" plus +® LF [FS]® (cobalt blue)**  
Production based on PE-UHMW SG 1.1

---

**Original Material "S" plus +® LF ESD [FS]® (black)**  
Production based on PE-UHMW SG 1.1

---

**Original Material "S" plus +® AB [FS]® (sky-blue)**  
Production based on PE-UHMW SG 1.2

---

**Original Material "S" plus +® TLS [FS]® (ruby red)**  
Production based on PE-UHMW SG 1.1

---

**Original Material "S" plus +® GB [FS]® (light-green)**  
Production based on PE-UHMW SG 1.1

---

**Original Material "S" plus +® ESD [FS]® (black)**  
Production based on PE-UHMW SG 1.2

---

**Muralen® green [FS]®**  
Production based on PE-HMW SG 2.1

---

**Muralen® natural [FS]®**  
Production based on PE-HMW SG 2.1

---

**Muralen® black antistatic [FS]®**  
Production based on PE-HMW SG 2.1

---

**Muralen® coloured [FS]®**  
Production based on PE-HMW SG 2.1

---

**Muralen® plus + AB [FS]® (sky-blue)**  
Production based on PE-HMW SG 2.1

---



---

**Overview of Murtfeldt technical plastics that are approved for use in the food industry as per Regulation (EC) No. 1935/2004 and Regulation (EU) No. 10/2011**

---

**Murlubric® blue [FS]®**  
Production based on PA6C/Oil

---

**Murylon® B natural [FS]®**  
Production based on PA6

---

**Murylon® A natural [FS]®**  
Production based on PA66

---

**Murytal® C natural [FS]®**  
Production based on POM-C

---

**Murytal® C blue [FS]®**  
Production based on POM-C

---

**Murylat® [FS]® (natural and black)**  
Production based on PET

---

**Murylat® SP [FS]® (light-grey)**  
Production based on PETP

---



---

**Overview of Murtfeldt high-performance plastics that are approved for use in the food industry as per Regulation (EC) No. 1935/2004 and Regulation (EU) No. 10/2011**

---

**Murinyl® [FS]® natural**  
Production based on PVDF

---

**Murflor® [FS]® natural**  
Production based on PTFE

---

**Murinit® SP [FS]® (blue)**  
Production based on PPS-SP

---

**Murpec® natural [FS]®**  
Production based on PEEK

---

[FS] ("food-safe") will be added to the names of these products. In addition, on request Murtfeldt is able to carry out individual migration tests for customers for other colours or types of technical plastics.

**If you require more detailed information on the content of Regulation (EC) No. 1935/2004 and Regulation (EU) No. 10/2011, please visit us at [murtfeldt.com](http://murtfeldt.com)!**



ORIGINAL MATERIAL "S"® green / ORIGINAL MATERIAL "S"® natural  
 ORIGINAL MATERIAL "S"® green [FS]® / ORIGINAL MATERIAL "S"® natural [FS]®

Since the 1950s, Material "S"® has been tried and tested a thousand times over for a wide range of applications in power engineering and conveyor technology.

Material "S"® is based on virgin, ultra-high molecular weight low pressure polyethylene and significantly exceeds the requirements of DIN 16972. Original Material "S"® is one of the most successful groups of materials in the industrial plastics sector.

In particular, Original Material "S"® green has established itself as a branded product in the plastics sector. It is used in all applications where a technical, high-performance plastic is required. Original Material "S"® green is synonymous with excellent slide properties, high wear resistance, and a long lifetime.

**SPECIAL PROPERTIES**

- Extremely high wear resistance – even in abrasive applications
- Excellent slide properties
- High impact strength
- Extremely good resistance to chemicals
- Excellent shock and impact absorption
- Good anti-adhesion properties
- No moisture absorption
- Available in all RAL colours (minimum purchase quantity of 600kg for materials not kept on stock)

- Electrically isolating ("S" green, natural, and colours)
- Approved for use in the food industry (EU and FDA)
- Original Material "S"® is also available with a molecular weight of up to 9 million g/mol.

**POSSIBILITIES OF USE**

- Slide bearings
- Chain guides
- Highly wear-resistant antistatic slide segments
- Slide profiles

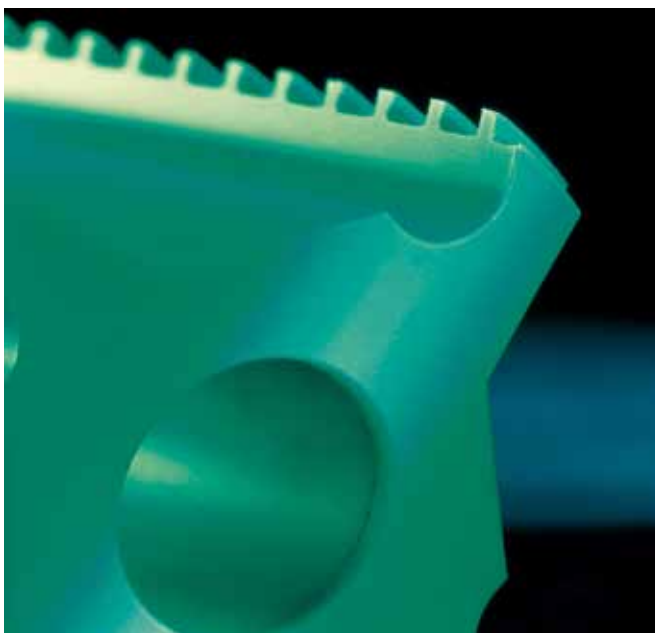

# ORIGINAL MATERIAL "S"<sup>®</sup> black ORIGINAL MATERIAL "S"<sup>®</sup> black [FS]<sup>®</sup>

Original Material "S"<sup>®</sup> black has the same properties as Original Material "S"<sup>®</sup> green/natural. In addition, it is also electrostatically conductive due to the addition of additives.

## SPECIAL PROPERTIES

- Extremely high wear resistance – even in abrasive applications
- Antistatic
- Excellent slide properties
- High impact strength
- Very good resistance to chemicals
- Excellent impact/shock resistance
- Good anti-adhesion properties
- No moisture absorption
- Suitable for all devices and machines that are subject to Directive 94/9/EC (ATEX 95)

## POSSIBILITIES OF USE

- Belt guides
- Highly wear-resistant antistatic slide segments
- Slide profiles



## MATERIAL "S"<sup>®</sup> 1000

This material is exclusively produced from ultra-high molecular weight polyethylene powder that is mixed with finely milled Original Material "S"<sup>®</sup>. The mixing process is computer-monitored. The fine milled material is compression-moulded at high pressure and temperatures to form new semi-finished products. This results in a high-quality material with an exceptional price/performance ratio that is characterized by exceptional abrasion resistance and good slide properties. Material "S"<sup>®</sup> 1000 is physiologically safe.

### SPECIAL PROPERTIES

- Good wear resistance properties
- Good slide properties
- Good anti-adhesion properties
- No moisture absorption
- Electrically isolating  
(Original Material "S"<sup>®</sup> 1000 green)
- Antistatic  
(Original Material "S"<sup>®</sup> 1000 black)
- Economical environmentally friendly

### POSSIBILITIES OF USE

- Slide bearings
- Chain guides
- Wear-resistant slide segments
- Slide profiles







## MURALEN® MURALEN® [FS]®

Muralen® is based on high molecular weight polyethylene (PE-HMW) and is ideally suited for use in applications that require the generally impressive material properties of polyethylene. However, it is only used in cases where the excellent slide and wear resistance properties of Original Material "S"® are not required. Because of its great cut, impact, and shock resistance, this material is often used to make underlays for cutting and punching machines and for ram guards.



## MURALEN® black antistatic MURALEN® black antistatic [FS]®

This material has the same properties as Muralen® but also has an antistatic effect.

### POSSIBILITIES OF USE

- Chopping boards/underlays for cutting machines
- Ram guards in supermarkets, cold stores, and abattoirs



## MURALEN® plus+ AB MURALEN® plus+ AB [FS]®



This material has the same properties as Muralen® but also has an antimicrobial effect.

### SPECIAL PROPERTIES

- High cut resistance
- Good shock and impact absorption
- Good resistance to chemicals
- Good anti-adhesion properties
- Approved for use in the food industry (EU and FDA)
- Available in all RAL colours (minimum purchase quantity of 600kg for materials not kept on stock)
- Good weldability
- Antibacterial properties (Muralen® plus+ AB)
- Antistatic (Muralen® Black)



# ORIGINAL MATERIAL "S" plus+<sup>®</sup> ESD ORIGINAL MATERIAL "S" plus+<sup>®</sup> ESD [FS]<sup>®</sup>

Thanks to its extremely low electrical resistance, Material "S"<sup>®</sup> plus+ ESD is an optimum conductor. Full voltage dissipation for earthed components at maximum speed enables safe, spark-free work. This material provides a cost-effective alternative to carbon-filled PTFE.

## SPECIAL PROPERTIES

- Very good conductivity (surface resistance of  $< 10^4 \Omega$ )
- Voltage dissipation on surface in less than 0.1s
- Cost-effective alternative to carbon-filled PTFE
- Suitable for devices and machines subject to Directive 94/9/EC (ATEX 95)
- Approved for use in the food industry (EU and FDA)

## POSSIBILITIES OF USE

- In the automotive and semiconductor sectors as, for example, full-surface sliding bases for modular link belts
- As work piece carriers for sensitive electronic components



# ORIGINAL MATERIAL "S" plus+<sup>®</sup> LF ORIGINAL MATERIAL "S" plus+<sup>®</sup> LF [FS]<sup>®</sup>

When developing this material Murtfeldt managed to further slash the sliding friction coefficient by half. The particularly great feature of this material is that this value is constant and is achieved even at low friction intensities. The required driving force is drastically reduced, meaning that your motors need less energy and are thus significantly more economical to run. This innovative material enables an increased machine running speed at the same time as less abrasion and thus a lower maintenance requirement. As a result, the material significantly contributes to an increase in your productivity.

## SPECIAL PROPERTIES

- Constantly low sliding friction coefficient during operation
- Energy saving of up to 50%
- No stick/slip effect
- Self-lubricating
- Protects the sliding partner
- Excellent acoustic insulation
- No water absorption
- Reduction in drive power with no reduction in performance
- Approved for use in the food industry (EU and FDA)

## POSSIBILITIES OF USE

- Guides for PET bottle conveyors
- Ideal wherever high slide speeds are required

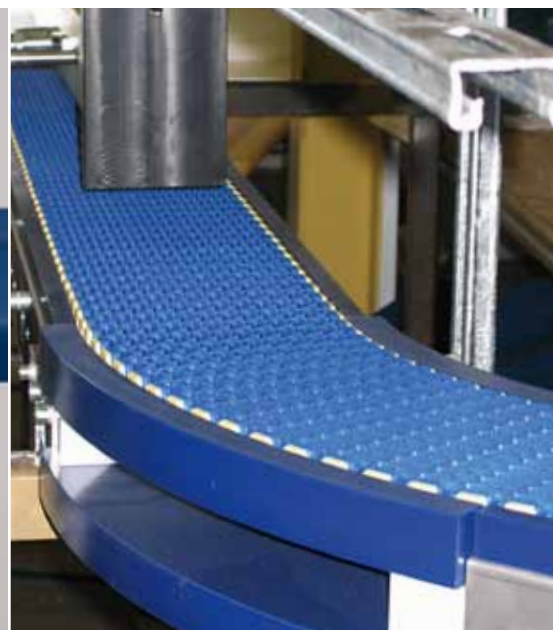



# ORIGINAL MATERIAL "S" plus+<sup>®</sup> LF ESD ORIGINAL MATERIAL "S" plus+<sup>®</sup> LF ESD [FS]<sup>®</sup>

The use of this plastic saves energy and improves the efficiency of your machines thanks to its low friction resistance. The sliding friction coefficient is reduced by up to 50 percent with this material – and so too the energy consumption for the drive power required. This plastic offers real energy-saving potential. Thanks to the additive used, Original Material "S"<sup>®</sup> plus+ LF ESD is electrically conductive, enabling voltage to be dissipated at maximum speed with the same maximum friction resistance.

## SPECIAL PROPERTIES

- Extremely high conductivity
- Voltage dissipation on the surface in less than 0.1s
- Reduction in drive power with no reduction in performance
- Saves up to 50% energy
- Minimal and constant sliding friction coefficient even in continuous operation
- Self-lubricating
- Approved for use in the food industry (EU and/or FDA)

## POSSIBILITIES OF USE

- As a solid sliding base in the semi-conductor industry
- For modular chain and conveyor belts
- Guides for PET bottle conveyors
- As workpiece carriers for sensitive electronic components
- Guides and slide elements for machine construction



## ORIGINAL MATERIAL "S" plus+® LFP ESD

Like its „siblings“ Original Material "S" plus+® LF and LF ESD, this plastic also impresses users with its low-friction properties and high wear resistance thanks to a constantly low sliding friction coefficient. In particular, its slide optimization properties come into their own with a sliding partner made from POM or PP, enabling an increased dynamic load-bearing capacity for conveyors in comparison with Original Material "S" plus+® ESD. At the same time, abrasion and thus the maintenance intensity are reduced. However, unlike the two „LF“ materials, Original Material "S" plus+® LFP ESD has no additive containing silicone. For this reason, this material is particularly suitable for use in the automotive sector, where attitudes towards substances that are detrimental to paint adhesion are particularly critical.

### SPECIAL PROPERTIES

- **Electrical conductivity (compliant with ATEX 95)**
- **Free from substances that disrupt paint adhesion**
- **Very good slide properties when used with POM and PP**
- **Very good wear and abrasion resistance**
- **Self-lubricating**
- **Low and constant sliding friction coefficient, even in continuous operation**
- **Up to 50% energy conservation**
- **Increased dynamic load-bearing capacity**

### POSSIBILITIES OF USE

- **Use in production plants for the automotive industry**
- **Sliding base for slat band chains, modular link belts, and much more**

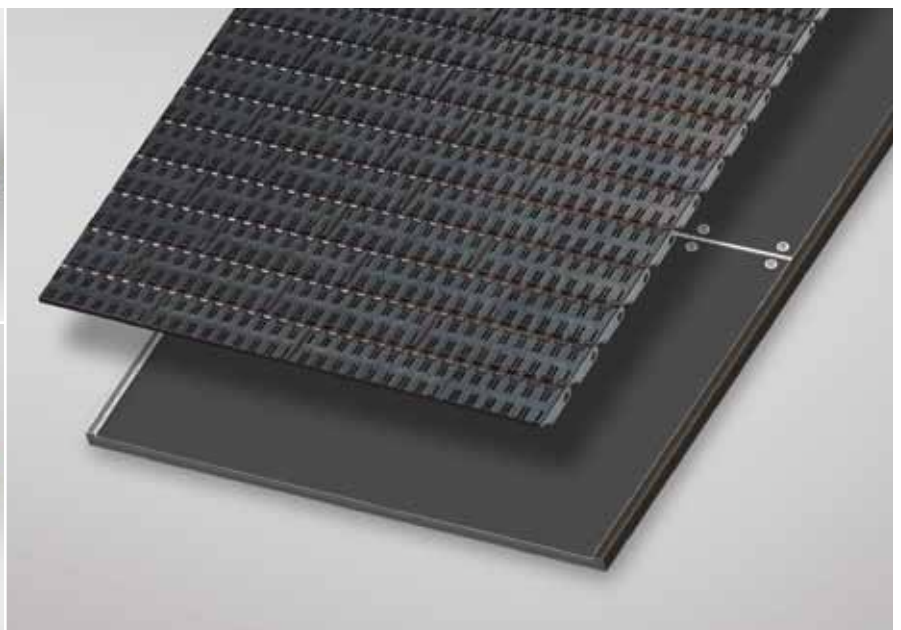
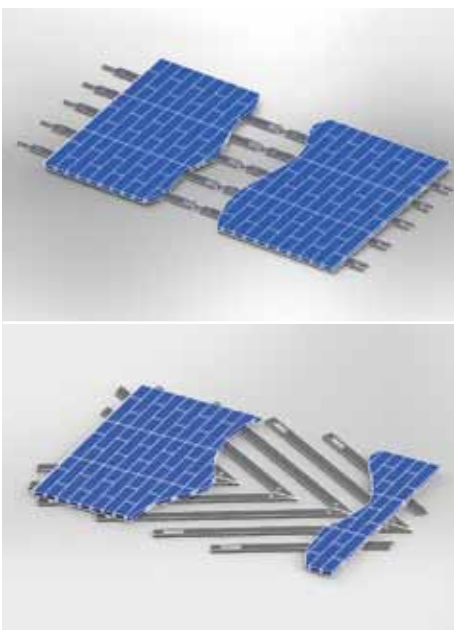

## MATERIAL "S"<sup>®</sup> 8000

This material results from the further development of a tried-and-tested material. Experiences of over 50 years of producing Original Material "S"<sup>®</sup> have contributed to the development of this material. This involved improving already impressive material properties. For example, the self-lubricating character of this material has resulted in an improved sliding friction coefficient in comparison with Original Material "S". Original Material "S"<sup>®</sup> 8000 is ideally suited for use in sliding guides, slide segments, and slide bearings.

### SPECIAL PROPERTIES

- Self-lubricating - lower sliding friction coefficient
- Increased wear resistance
- Excellent impact/shock resistance
- Good resistance to chemicals
- Good anti-adhesion properties
- Electrically isolating
- Better resistance to UV rays than Original Material "S"<sup>®</sup> green/natural

### POSSIBILITIES OF USE

- Highly wear-resistant slide elements
- Sliding guides, slide segments, and sliding bearings





## ORIGINAL MATERIAL "S"® plus+ Bright ESD

For the first time, it has been possible to develop a light plastic with high conductivity and a voltage-dissipating effect on earthed components. This combination was not previously possible. This material is ideal for use in applications where a high value is placed on hygiene and antistatic characteristics.

In many work environments, light surfaces are mandatory. The conductivity of Material "S"® plus+ Bright ESD provides optimum safety. Its properties largely match those of Material "S"® plus+ ESD.

### SPECIAL PROPERTIES

- Very good conductivity (surface resistance of  $\leq 10^5 \Omega$ )
- Ideally suited to light, dust-free environments
- Suitable for devices and machines subject to Directive 94/9/EC (ATEX95)

### POSSIBILITIES OF USE

- Clean room technology
- Medicine
- Laboratories



# ORIGINAL MATERIAL "S" plus+<sup>®</sup> AB ORIGINAL MATERIAL "S" plus+<sup>®</sup> AB [FS]<sup>®</sup>

Material "S"<sup>®</sup> plus+ AB contains special substances that prevent the growth of bacteria and other microbes at the same time as protecting the environment and people. The material is thus ideally suited for use when manufacturing and processing foods. It can reduce the growth of microbes on surfaces by between 99.96 to 99.99% in comparison with materials with no special additives. This means that it can virtually eradicate unpleasant smells and the formation of biofilms. "S"<sup>®</sup> plus+ AB combines antibacterial properties with the exceptional characteristics of the "S"<sup>®</sup> plus+ range.

## SPECIAL PROPERTIES

- Reduces bacteria and microbe growth by around 99.99 %
- Approved for use in the food industry (EU and FDA)
- High wear resistance
- Long lifetime
- Good resistance to chemicals
- Good acoustic insulation
- No moisture absorption

## POSSIBILITIES OF USE

- Curve and chain guides and slide bars or components in the food and beverage industry (especially in the meat sector and in dairies and breweries)
- Slide and drive elements in medical and food technology
- In areas where high standards of hygiene are required, such as the storage and handling of food, cosmetics, and drugs



## ORIGINAL MATERIAL "S" plus+® FP [FS]®

Original Material "S"® plus+ FP [FS] is a new technical plastic that completely meets the requirements of the food sector for the detectability of plastic foreign bodies in foods. "FP" stands for "food protect" and embodies two vital properties: This product is both food-safe and metal-detectable. Metallic foreign bodies in foods are safely detected by metal detectors and removed. However, plastic particles from plant components can be problematic. Thanks to the use of additives in Original Material "S"® plus+ FP [FS], all commonly used metal detectors in the food industry can now detect and remove plastic particles.

### SPECIAL PROPERTIES

- Metal-detectable in all commonly used industrial detectors
- Approved for use in the food industry (EU and FDA)
- Very good wear and abrasion resistance
- Extremely good machinability
- Excellent chemical resistance
- Increased continuous use temperature of 100°C

### POSSIBILITIES OF USE

- Curve and chain guides, slide bars, or components used for food production/in the beverage industry
- Slide and drive elements in medical and food technology
- In all areas where hygiene and metal-detectability are required

#### Information on its use

The detection capability of Original Material "S"® plus+ FP [FS] is determined by the "product effect" of the products to be tested and the sensitivity of the detector. As a precise adjustment of your detector is required, we will be happy to send you test samples of our Original Material "S"® plus+ FP [FS].





# ORIGINAL MATERIAL "S" plus+® GB ORIGINAL MATERIAL "S" plus+® GB [FS]®

This material is used for applications that involve manufacturing and transportation at high pressure. The balanced quantity of micro glass beads in Material "S" plus+ GB provides the combined benefits of extremely high molecular weight polyethylene and glass. The glass beads that protrude from the surface give a rounded and hard sliding surface.

## SPECIAL PROPERTIES

- Protects the sliding partner (unlike glass-fibre reinforced plastics)
- Extremely good resistance to chemicals
- Approved for use in the food industry (EU and FDA)

## POSSIBILITIES OF USE

- Guides for PET bottle necks in the beverage industry
- In abrasive environments (for example, environments where lint is present)

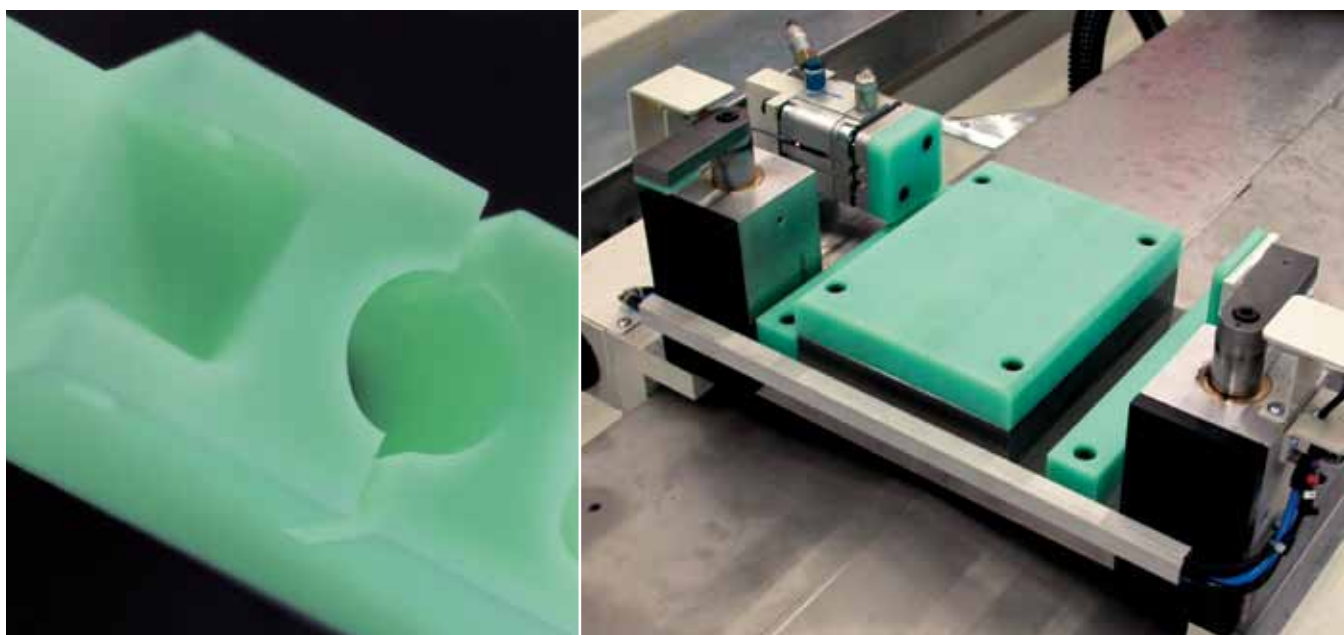

# ORIGINAL MATERIAL "S" plus+<sup>®</sup> TLS ORIGINAL MATERIAL "S" plus+<sup>®</sup> TLS [FS]<sup>®</sup>

Industrial applications are often subject to high temperatures at which Original Material "S"<sup>®</sup> could previously not be used. Such applications require materials with familiar characteristics such as wear, impact, and chemical resistance. The new Original Material "S"<sup>®</sup> plus+ TLS now offers – for the first time – a material that can be used in situations for which Original Material "S"<sup>®</sup> was not suited. Even at high operating temperatures of up to 120°C for short periods of time and constant service temperatures of up to 100°C, the molecular structure of this ultra-high molecular weight low-density polyethylene does not change. This is because the thermal oxidation point has been increased through the use of a newly developed additive. "S"<sup>®</sup> plus+ TLS is thus suitable for a wide range of industrial applications that are subject to sustained high temperatures.

## SPECIAL PROPERTIES

- Increased constant service temperature of 100°C
- Extremely good wear and abrasion resistance
- Excellent resistance to chemicals
- Excellent machinability

## POSSIBILITIES OF USE

- Slide and guide elements for many different industrial applications in the middle temperature ranges, e.g. drying ovens and chain trough conveyors.



# MURLUBRIC®



# MURLUBRIC® blue [FS]®



Mineral oil is integrated into this modified cast polyamide during polymerization. As a result, the material has self-lubricating properties and retains its excellent characteristics for its entire lifetime. This significantly reduces operating and maintenance costs.

This material has practically the best slide properties of our entire range. In addition, Murlubric® is extremely wear-resistant and is suitable for use in high-stress slide and wearing applications even at high speeds.

Murlubric® blue [FS] is approved for use in the food industry (EU and FDA) compared with black Murlubric®.

## SPECIAL PROPERTIES

- Excellent slide properties
- Wear-resistant, even in abrasive applications
- High mechanical strength
- Self-lubricating
- Vibration-free running
- Low residual stress
- Good lubricant resistance
- High dynamic load-bearing capacity

## POSSIBILITIES OF USE

- Rollers
- Highly-stressed slide elements (lifetime is 5 to 10 times longer than for normal polyamide)
- Chain guide rails
- Radial sliding bearings
- Murlubric® blue [FS] is approved for use in the food industry (EU und FDA/only [FS] type)





MURYLON® B  
MURYLON® B natur [FS]®

Murylon® B natural has the best impact resistance of all Murylon materials. This material is especially suited for use in machine construction thanks to an excellent combination of mechanical properties.

SPECIAL PROPERTIES

- Exceptional resistance
- Good impact strength
- Low cold flow characteristics
- Approved for use in the food industry (EU and FDA)

POSSIBILITIES OF USE

- Rollers
- Slide bearings
- Parts subject to high impacts and shocks

MURYLON® A  
MURYLON® A natur [FS]®

This material combines the excellent properties of the Murylon® range with additional high tensile and compressive strength, increased wear resistance, and a lower level of moisture absorption than Murylon® B.

SPECIAL PROPERTIES

- Better wear resistance than Murylon® B
- Improved tensile and compressive strength
- Better temperature resistance than Murylon® B
- Extremely good fatigue strength
- Low cold flow characteristics
- Approved for use in the food industry (EU and FDA)



POSSIBILITIES OF USE

- Rollers
- Slide bearings
- Slide elements
- Components under varying stress
- Parts subject to high impacts and shocks



## MURYLON® A GF

The properties of this material surpass the already impressive characteristics of Murylon® A. This is possible thanks to admixed glass fibres. The result: a clear improvement in cold flow behaviour and dimensional stability. This enables higher static pressure loads to be endured.

### SPECIAL PROPERTIES

- Improved compressive strength
- Excellent cold flow behaviour
- Increased rigidity
- Better dimensional stability than other Murylon® materials
- Can be used at higher temperatures (+120°C)
- Low moisture absorption

### POSSIBILITIES OF USE

- Highly stressed load-bearing machine parts

## MURYLON® 6 Cast

Murylon® 6 CAST has extremely low levels of residual stress thanks to the casting procedure used to produce it. This material is therefore ideally suited to extensively processed components.

### SPECIAL PROPERTIES

- Good impact resistance
- Low cold flow characteristics
- Optimized wear properties (similar to those of Murylon® A)
- Low residual stress
- Flexible production of large-volume products possible
- Good fatigue strength

### POSSIBILITIES OF USE

- Runners
- Slide elements
- Parts subject to high impacts
- Cog and chain wheels
- Pulleys



## MURDOPOL®

The main advantage of this material is its fantastic ability to create firm plastic/metal connections. This is made possible by the casting procedure used in its production, which involves casting around a steel core. The plastic and metal cutting deformation provides an absolutely accurate rotation for cog wheels and rollers. Murdopol® has extremely high shock and impact resistance characteristics and good emergency running characteristics thanks to its high wear resistance.

### SPECIAL PROPERTIES

- Good shock and impact resistance
- Low residual stress
- Metal core surrounded by cast plastic available
- Good damping and vibration behaviour
- Lowest moisture absorption of all polyamides
- Good resistance to chemicals
- Dimensionally stable

### POSSIBILITIES OF USE

- Cog wheels with steel core
- Pulleys
- Humid usage sites
- Parts subject to high impacts
- Cam disks and sprockets





MURYTAL® C  
 MURYTAL® C natural [FS]® MURYTAL® C blue [FS]®

Thanks to their extremely low absorption of moisture, Murytal® materials are ideally suited for use as electronic isolation components. A fine crystalline structure and high yield strength mean that Murytal® C has a high ability to regain its original form.

Provided with the same properties as Murytal® C natural, the blue plastic is ideal for use in the food sector thanks to its colour.

**SPECIAL PROPERTIES**

- High rigidity
- Excellent ability to regain its form
- Extremely good electric isolation properties
- Practically no moisture absorption
- Good resistance to chemicals (pH 4 – 13)
- Approved for use in the food industry (EU and FDA) (Natural)
- Extremely good machinability
- Hydrolysis resistant to 80°C

**SPECIAL PROPERTIES**

- High rigidity
- Excellent ability to regain its form
- Extremely good electric isolation properties
- Practically no moisture absorption
- Good resistance to chemicals (pH 4 – 13)
- Approved for use in the food industry (EU and FDA)
- Extremely good machinability
- Hydrolysis resistant to 80°C

**POSSIBILITIES OF USE FOR ALL MURYTAL® MATERIALS**

- Slide elements
- Cog wheels
- Cams
- Snap-on connections



## MURYTAL® H

In addition to the excellent properties of Murytal® C, Murytal® H is stronger and more rigid with a lower expansion coefficient.

### SPECIAL PROPERTIES

- Higher rigidity than Murytal® C
- Excellent ability to regain its form
- Extremely good electric isolation properties
- Practically no moisture absorption
- Good resistance to chemicals (pH 4 – 9)
- Extremely good machinability

## MURYTAL® ESD

Additives make this material conductive. The mechanical properties of the material are retained almost in their entirety.

### SPECIAL PROPERTIES

- Suitable for devices and machines subject to Directive 94/9/EC (ATEX95)

### POSSIBILITIES OF USE FOR ALL MURYTAL® MATERIALS

- Slide elements
- Cog wheels
- Cams
- Snap-on connections

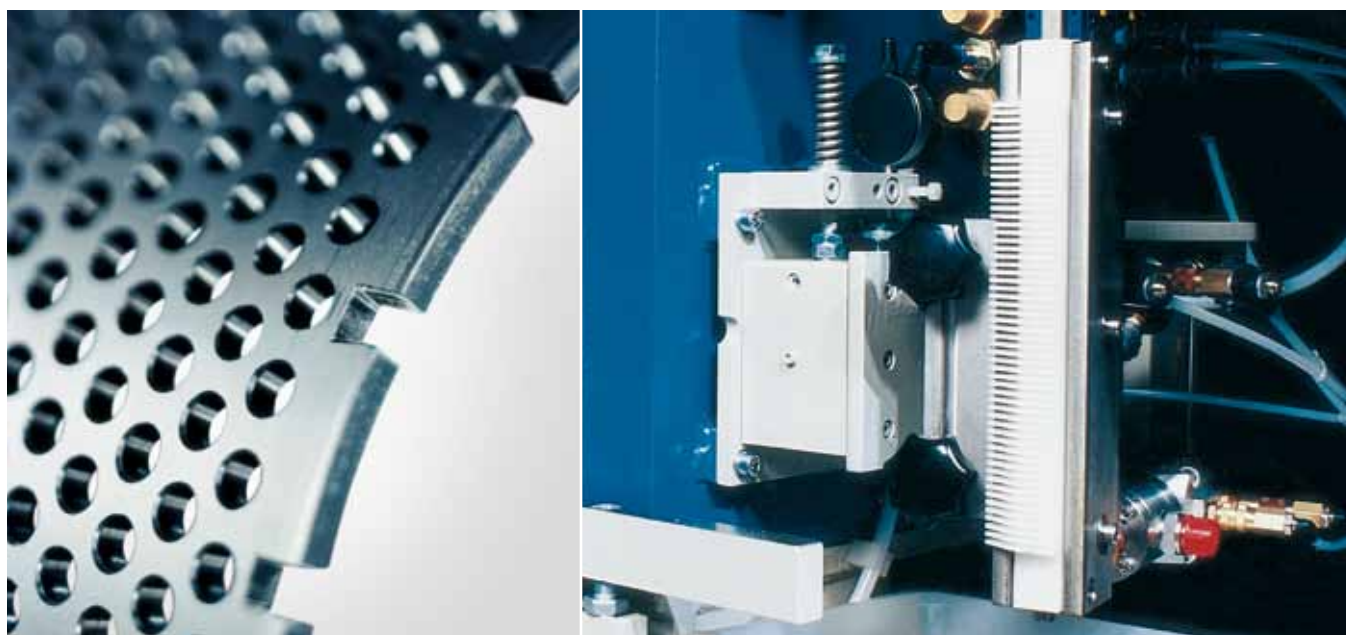

MURYLAT®  
MURYLAT® [FS]®

MURYLAT® SP  
MURYLAT® SP [FS]®

Thanks to its extremely low absorption of moisture and low expansion coefficient, Murylat® is ideally suited for the processing of precision parts. Murylat® has an extremely high hardness grade and can withstand extreme static stresses exceptionally well.

Murylat® SP combines the properties of Murylat® with improved wear and friction characteristics. It also has increased dynamic resilience which, for example, significantly reduces the required drive power for your plants. This is made possible by the homogeneous distribution of solid lubricant.

POSSIBILITIES OF USE FOR MURYLAT®

- Machine parts with narrow tolerances
- Bearing and transmission elements
- Highly stressed chain guide rails
- Chain wheels

SPECIAL PROPERTIES

- High creep strength – even at high temperatures
- Very good dimensional stability
- Low moisture absorption
- Approved for use in the food industry (EU and FDA) (Natural)
- Extremely good electric isolation properties

SPECIAL PROPERTIES

- Increased wear resistance
- Better slide properties
- High creep strength – even at high temperatures
- Very good dimensional stability
- High dynamic load-bearing capacity
- Low moisture absorption
- Approved for use in the food industry (EU and FDA)

POSSIBILITIES OF USE FOR MURYLAT® SP

- Wear-resistant, highly stressed slide elements with narrow tolerances
- Bushes/sliding bearings
- Guides





## MURYLON® HT



The use of this highly temperature-resistant polyamide enables reliable operation up to a constant service temperature of +155°C. The material retains its rigidity and creep strength over the entire temperature range far better than other Murylon® types. Thanks to its increased resistance against oxidative degradation, it is usually used in applications at above +80°C.

### SPECIAL PROPERTIES

- Highly wear-resistant and good slide properties, especially at high temperatures
- Good resistance to thermal aging
- High creep resistance

### POSSIBILITIES OF USE

- Sliding bearings
- Chain guide rails and guides for use at high temperatures

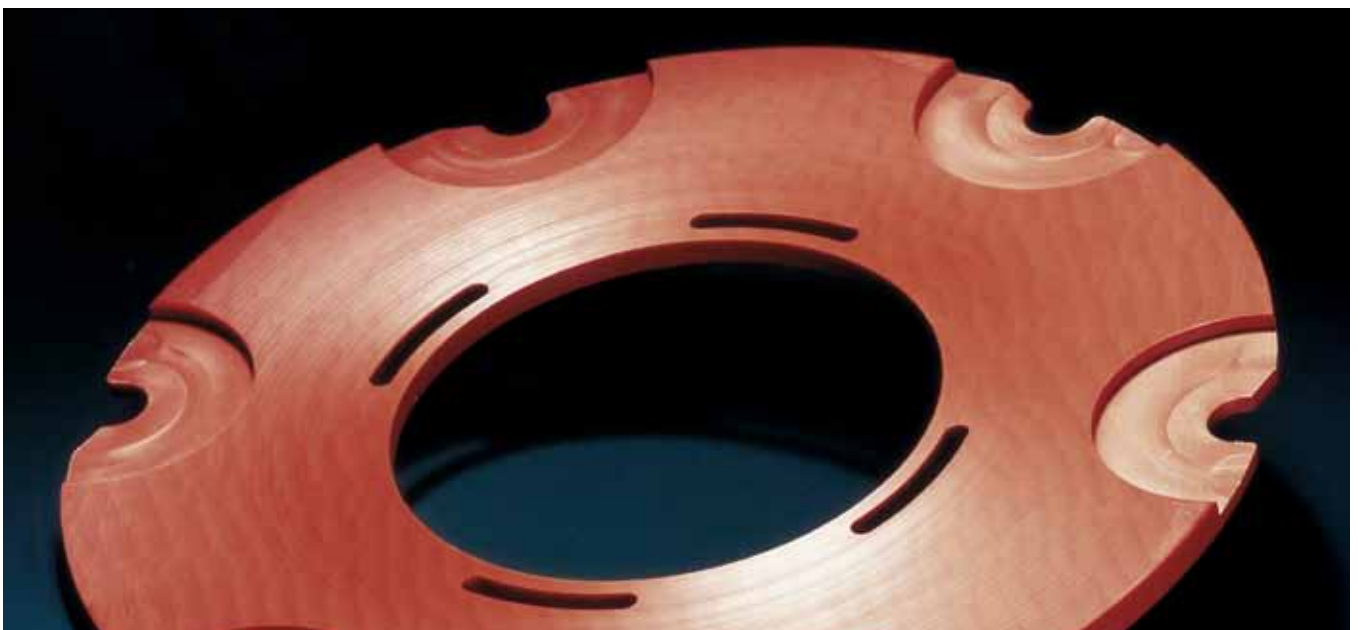



# MURINYL®

## MURINYL® [FS]®

This material is ideally suited for use in the food sector and medical industry. As a fluorinated plastic, Murinyl® is exceptionally resistant to chemicals, hydrolysis, and sterilization. Moreover, the properties of the material change very little even at high service temperatures and after long-term exposure to UV radiation, meaning that Murinyl® is ideally suited for a wealth of applications both inside and outside.

### SPECIAL PROPERTIES

- Good wear resistance
- Good rigidity
- Higher compressive strength than Murflor®
- High constant service temperature
- Good resistance to chemicals
- Resistant to sterilization
- No stress corrosion possible
- Very good resistance to UV rays and adverse weather conditions
- No moisture absorption
- Approved for use in the food industry (EU and FDA)

### POSSIBILITIES OF USE

- Construction of chemical apparatus
- Valve and pump parts
- Pharmaceutical and food sectors



# MURFLOR®

## MURFLOR® [FS]®

Murflor® materials are ideally suited to use in applications that require an excellent resistance to chemicals and heating steam. Murflor®'s working range starts at -200°C and can extend to +260°C with no mechanical load. Murflor® also has the lowest dynamic friction coefficient of all thermoplastics.

### SPECIAL PROPERTIES

- Best dynamic friction properties of all thermoplastics
- No stick/slip effect
- Very good anti-adhesion properties
- Electrically isolating
- Very high resistance to chemicals
- Very high resistance to hydrolysis
- Very tough, even at low temperatures
- Approved for use in the food industry (FDA)

### POSSIBILITIES OF USE

- Construction of chemical apparatus
- Sliding guides and seals for use at high temperatures
- Slide bearings



## MURFLOR® + Carbon

The integration of 25% carbon increases the wear resistance, hardness, and creep strength of this material. Murflor® + Carbon is used, for example, when electrical conductivity is required and Material "S"® Black Antistatic cannot be used because the ambient temperature is too high.

### SPECIAL PROPERTIES

- Higher wear resistance than Murflor®
- Very good slide properties
- Low stick/slip effect
- Electrically conductive
- Suitable for devices and machines subject to Directive 94/9/EC (ATEX95)

### POSSIBILITIES OF USE

- Sliding guides and slide bearings

## MURFLOR® + Bronze

The addition of 60% bronze to the base material reduces the expansion coefficient and gives lower sliding wear.

### SPECIAL PROPERTIES

- Lower sliding wear than Murflor®
- Good slide properties
- Low stick/slip effect
- Higher compressive strength than Murflor®

### POSSIBILITIES OF USE

- Sliding guides and slide bearings

## MURFLOR® + Glass

The use of 25% glass fibres in the Murflor® base material improves its mechanical properties. The increased compressive strength and improved rigidity allow applications that are subject to heightened stress.

### SPECIAL PROPERTIES

- Higher burst strength than Murflor®
- Higher rigidity than Murflor®
- Reduced cold flow behaviour
- Extremely good wear resistance

### POSSIBILITIES OF USE

- Slide bars and plates
- Gaskets

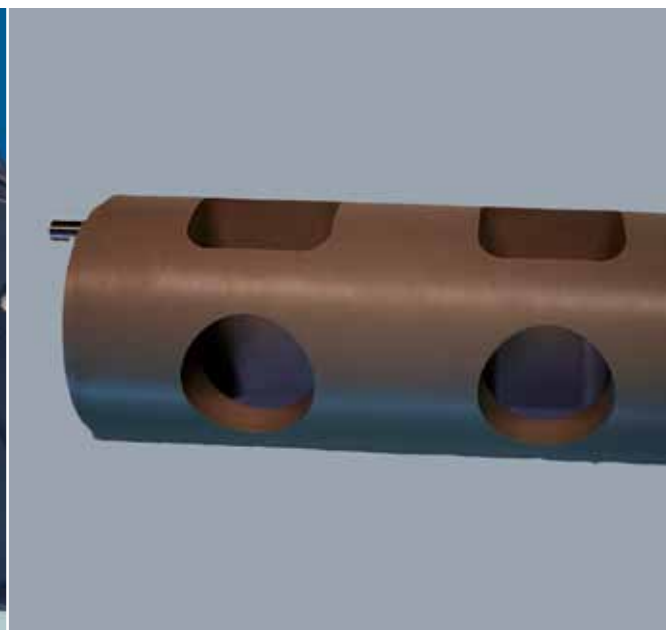

# MURINIT® SP MURINIT® SP [FS]®

Thanks to the low fibre content and integrated solid lubricant, this high-performance material offers an excellent combination of good slide and wear behaviour, high strength, and dimensional stability – even at high temperatures. Murinit® SP also has a good resistance to chemicals and hydrolysis.

## SPECIAL PROPERTIES

- High wear resistance
- Good slide properties
- Good resistance to chemicals and hydrolysis
- Excellent creep and compressive strength
- Good electrical isolation properties
- Low thermal expansion coefficient
- Approved for use in the food industry (EU and/or FDA)

## POSSIBILITIES OF USE

- Wear parts subject to temperature stress
- Slide elements





# MURPEC® MURPEC® [FS]®

In comparison with other thermoplastics, Murpec® has an exceptionally low thermal expansion coefficient. This property provides optimum dimensional stability and means that dimensions do not change even if used in wet environments. Because of the high glass transition temperature, the material's rigidity and strength are retained almost in their entirety even at high temperatures. Murpec® materials are extremely resistant to deformation and exceptionally abrasion-proof.

### SPECIAL PROPERTIES

- High wear resistance
- Low expansion coefficient
- Electrically isolating
- High temperature resistance
- Flame-resistant
- High compressive strength
- High resistance to energy radiation

- Excellent resistance to chemicals and heating steam
- Approved for use in the food industry (EU and/or FDA)

### POSSIBILITIES OF USE

- Sliding guides
- Cog wheels
- Parts subject to temperature stress

### POSSIBILITIES OF USE MURPEC® SP

- Highly-stressed wear parts
- Sliding guides
- Slide bearings

# MURPEC® SP

Modified Murpec® SP provides excellent slide properties in addition to good mechanical properties. This material variant also offers improved wear behaviour due to its special additives.

### SPECIAL PROPERTIES

- Better slide properties
- Increased wear resistance
- Very low expansion coefficient
- High temperature resistance
- Flame-resistant
- High compressive strength
- High resistance to energy radiation
- Excellent resistance to chemicals and heating steam



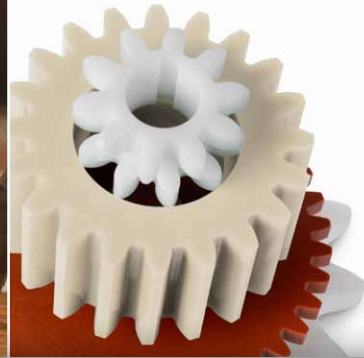

## INDIVIDUAL SOLUTIONS

# INDIVIDUAL SOLUTIONS

**Different need not be expensive**

## Leading the way

In more than 60 years of Murtfeldt's history, we have repeatedly seen that our success is a result of carefully watching the markets and their requirements. Whereas our company initially produced products for which there was a general demand, like new plastics or innovative chain tensioning systems, today we are seeing a new trend. Increasingly, companies are specialising to creating niche markets, offering custom products and using specific equipment and machinery for this. This orientation towards custom products is crucial for any business that wants to remain a successful player on the market in the long term.

## Designing individual finished parts together

A key focus at Murtfeldt is on custom manufacture. Our products are based on drawings or digital drawing files that we obtain from the customer or compile in collaboration with the customer. Our application engineers and technicians provide advice here. If machine elements are too complex or if it is difficult to sketch the actual situation on the phone or by e-mail, then our application advisers will call in to your office to obtain the specific data.

## Machining or 3D printing

We offer production by means of 3D printing in addition to our extensive machining possibilities. The range of the parts that we can produce is wide, from small series components to functional models and spare parts or visual or operational prototypes made from plastic.

## Innovative and sector-specific

Our products are aimed at practically any sector that uses high-quality industrial plastics, ranging from the food and packaging sectors to automation technology and medical technology. The possibilities are limited only by today's technology – not by the application.

The benefits for you
■ Parts manufactured in line with your own specification
■ Even small batches can be produced at economical prices
■ Parts produced from drawings or samples – which either you or we have provided
■ Free of charge advice on the material selection, material-appropriate design and, above all, relating to the use of our plastics



### State-of-the-art production facilities

Whether for cutting, milling, turning, profiling, drilling, vibratory grinding, welding or tempering – our machines and systems are state-of-the-art and offer a wide range of machining options. We can even produce the smallest batch sizes or individual parts at cost-effective prices. We focus, above all, on plastic-appropriate processing. There is therefore an ongoing dialogue at Murtfeldt between Research and Production.

### Here is an example: Traverse paths of our conventional and CNC milling cutters:

X-axis: up to 4000 mm

Y-axis: up to 2200 mm

Z-axis: up to 800 mm



### Our machinery at a glance

- 17 CNC milling stations
- 3 CNC universal milling machines
- 8 NC universal milling machines
- 7 CNC lathes
- 2 cyclic lathes
- 6 L and Z lathes
- 8 coordinate drilling machines
- 7 automatic profiling machines
- 7 table undercutters
- 4 panel dividing systems
- 5 format circular saws
- 2 four-sided planing machines
- 3 planers
- 1 rotary planer





## THE LATEST MANUFACTURING PROCEDURE: 3D PRINTING

Following an intensive test phase, Murtfeldt is now using „additive manufacturing“ as its latest production method – more commonly known as 3D printing. This new production process has proven itself to be an excellent enhancement of our existing manufacturing procedure, the machining of plastic parts. It is ideally suited to consolidating our core business offering in the area of small and ultra-small series of parts made from technical plastics.

In conjunction with our pool of service providers, we offer all common 3D printing procedures. The range of the parts that we can produce is wide, from small series components to functional models and spare parts or visual or operational prototypes made from plastic.

Murtfeldt has created its own upload tool for this for the company's Website. It quickly and easily loads 3D data to the Murtfeldt servers, where we're waiting for it to arrive. The potential customer quickly receives an individual quotation that is tailored to his or her specific needs. Murtfeldt Plastics checks the product to be manufactured, including a check of the production method. The type of production that is most beneficial to the customer dictates whether 3D printing or machining is used. If the customer does not have any 3D data, the Murtfeldt team of application engineers and technicians can naturally create this data in accordance with the specifications of the customer.

In addition, as of Automatica 2016, Murtfeldt itself has the world's latest additive manufacturing process. Here, carbon, Kevlar, and glass fibres are printed as continuous filaments. These strengthening fibres are added to the base material nylon/PA6 during the production process – also in an FDM procedure. This results in a really resilient component that remains highly flexible and is ideally suited to the manufacturing of individual machine parts for the production of mechanisms, tools, and assembly aids.

In the case of all 3D printing procedures, the integration of insert components such as threaded inserts and hexagon nuts is possible afterwards. Murtfeldt has a broad spectrum of further finishing procedures such as gluing, filling, grinding, painting, and laser marking.

**For more information about this topic, see [www.murprint.com](http://www.murprint.com).**



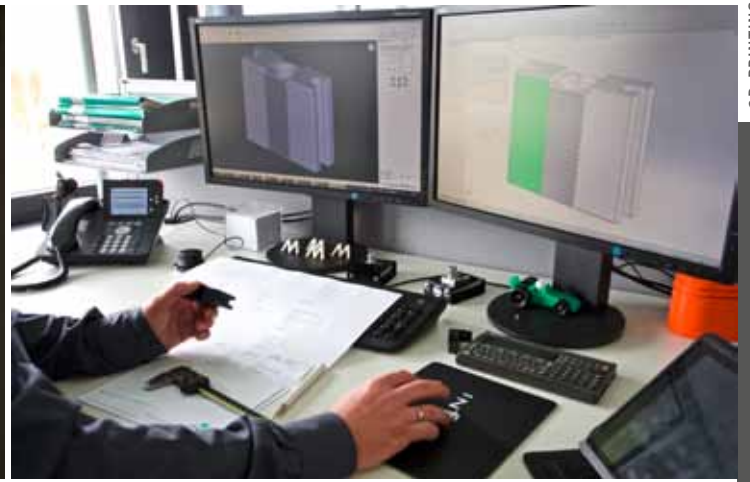
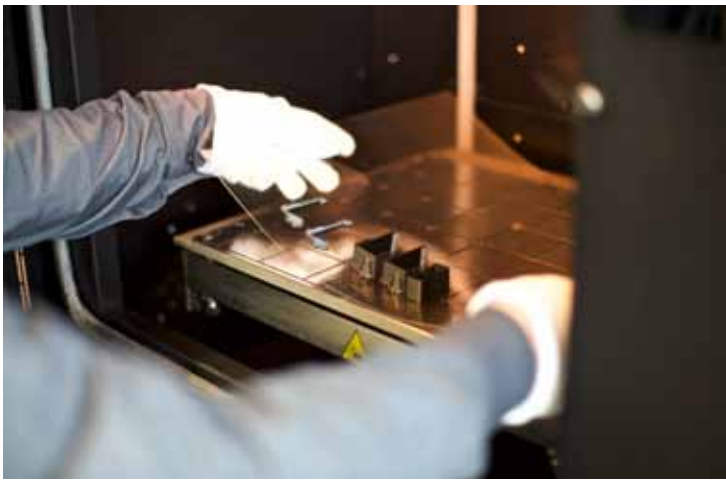
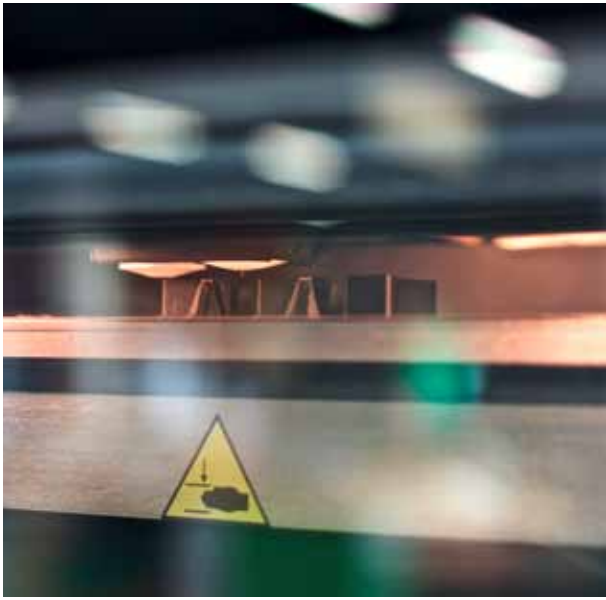

## PLASTIC CONVEYOR SCREWS

Murtfeldt tailor-made transport and conveyor screws are used in place of many construction parts, custom-manufactured to meet their users' needs – and stand out, not on account of their high cost, but rather because of their outstanding quality.

Murtfeldt offers a wide production range of individual conveyor screws – e.g. separation screws, grouping screws, 1-to-2 strand screws, 2-to-1 strand screws, dosing and conveying screws, turning screws or turning and grouping screws. They all transport goods constantly, quickly, and gently.

Murtfeldt also produces individually manufactured screws with drive properties. In addition to conveying goods, these screws use external tothing to drive other screws. Murtfeldt produces clockwise and anticlockwise screw elements.

Thanks to a new screw milling machine, Murtfeldt is able to produce screws of up to 2.5 metres. The 6-axis machining centre with traverse paths of  $x = 4,000$  mm,  $Y = 800$  mm, and  $Z = 800$  mm also has a special axis structure for the production of parts that are clamped on both sides with a diameter of 400 mm and a length of up to 2,500 mm. Moreover, there is special equipment for the production of the most complex of screws. The new plant is connected with special CAM software that is required for the production of custom screws.

### The benefits of plastic screws in comparison with metal screws

- less operating noise
- considerably lower weight
- easy to clean
- low centrifugal forces
- high resistance to impact and abrasion
- high impact toughness
- excellent glide behaviour
- high surface quality (important for protecting products)
- long lifetime
- And do not forget: Murtfeldt Plastics offers 100% reproducibility of its produced screws.





# COG WHEELS

## Top, demonstrable quality – tooth by tooth

Cog wheels are important functional parts that are subject to the highest quality requirements. The excellent material properties and almost unlimited possibilities with regard to shape make plastic cog wheels so successful.

Murtfeldt Plastics produces cog wheels through machining its own semi-finished products or by means of 3D printing (prototyping). We use the latest machine to carry out tailored production and achieve our high quality standards thanks to optimum material properties and current measurement methods.

Murtfeldt also uses current measurement methods to determine tooth values and shapes etc. 100% correctly. Among other equipment, we use a robot-assisted Mori Seiki NT X2000. This works on five axes at once, is extremely precise, and significantly reduces thermal displacement. A particular highlight of this machine is its six-sided machining: After the production cycle, the operator has a completely finished component in his or her hands.

### Main advantages for plastic cog wheels

- Corrosion-resistant
- Low-noise
- Maintenance-free
- Optimum emergency running characteristics
- Vibration-damping running
- Abrasion-resistant
- Impact-resistant
- Really tough

### Murtfeldt produces:

- Spur gears
- Inner sprockets
- Bevel gears
- Sprockets
- Special gearing
- Chain racks





# PRODUCT TURNERS

Murtfeldt Plastics develops and produces a wide range of product turners. These are turners for e.g. commercially available drinks cans and also for special formats that are developed completely in accordance with the individual requirements of the customer.

## We produce turners for e.g.:

- Folding boxes, cartons, and cardboard boxes
- Cans, bottles, and glasses
- Glass or plastic jars

## For the following sectors, among others:

- Food sector
- Pharmaceuticals and cosmetics industry
- Automotive sector
- Beverage industry
- Electrical industry

## Murtfeldt manufactures product turners with any turning angle and direction that can be used in virtually any production and processing stage:

- For alignment before or after filling or packaging
- For pre-filling cleaning
- Before and after labelling
- For sterilization by means of turning after filling

## Used material

We use our highly wear-resistant Original Material "S"<sup>®</sup> (PE-UHMW) to produce our turners. On request, this can also meet further requirements (temperature resistance, electrical conductivity, compliant with legal requirements for use in the food industry etc.).



One-part 90° turner

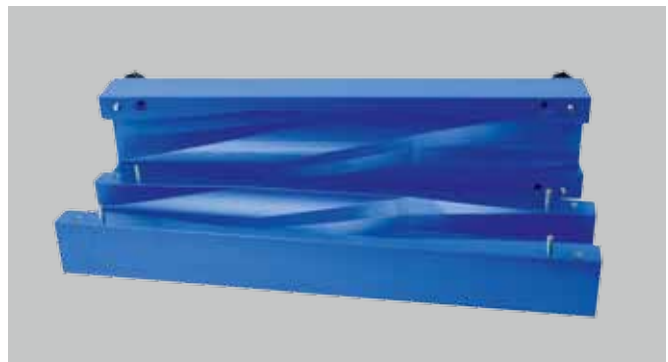

Closed 90° turner for the further processing of loose product units



2 × 180° turning station for cleaning glasses



Hinged 180° turner for drinks cans

**Individual assembly options for turners:**

- On an existing conveyor belt
- Between two conveyor belts
- For assembly with a low angle of inclination (10-15 degrees depending on the product) to ensure jam-free conveyance

**Advantages of Murtfeldt product turners:**

- Production on 5-axis machines with a cooling mechanism
- Guarantees a really good surface quality
- Only a low dynamic pressure due to excellent slide properties of the processed plastics
- Turners generally only consist of one or two plastic elements
- Seamless internal contour enables really quiet and gentle product running
- Stainless steel connection elements support hygienic requirements
- Use of plastics that are compliant with legal requirements for use in the food industry [FS] at the request of the customer
- Suitability of one turner for many product formats

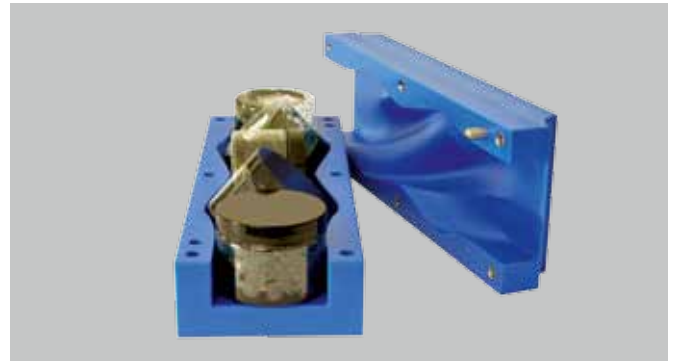

2 x 180° turning station for cleaning glasses

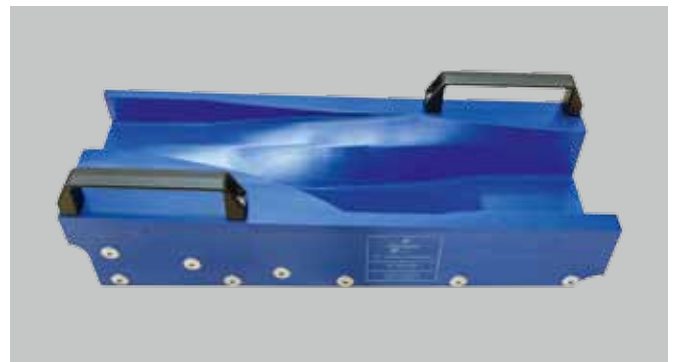

Open 90° turner ...



... for different folding box formats

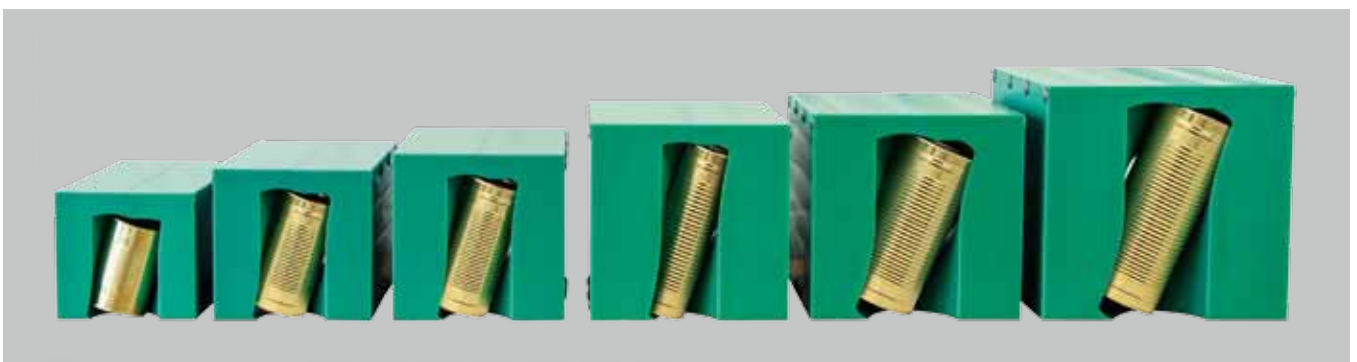

180° attachment turner in different sizes to be used depending on the product being manufactured

# RAM GUARDS

## Tailored plastic solutions

**Our plastic ram guards offer an impact-resistant alternative to solutions made from wood or metal.**

Murtfeldt's tailored solutions for ram protection and impact protection are already used in many areas. Unlike traditional solutions made from metal or wood, the design of ram protection profiles made from high-quality plastics offers a range of material-related advantages. These guards generally feature high durability and extreme impact resistance whilst retaining cost effectiveness

### RAM PROTECTION: ONE OBJECTIVE, LOTS OF SOLUTIONS!

Protect parts of buildings, plants, and your equipment using custom ram protection or impact protection by Murtfeldt that has been tailored to your needs in order to avoid high repair and maintenance costs.

Low moisture absorption, antistatic properties, high resistance to the cold or heat, or great slide properties? Murtfeldt uses the right plastics for your application in accordance with the requirements of the place of use. After all, not all materials are created equal. You can also benefit from the advantages of our EU and FDA-certified plastics that are compliant with legal requirements for use in the food industry for ram protection solutions in, for example, food-processing enterprises or the health/laboratory sector.

The Murtfeldt Application Technology team is there to provide you with free and non-binding advice about all of the possibilities open to you. We produce the required ram protection in accordance with your data and drawings or work with you to formulate the optimum solution and all files that are required for the production process. We do this online using TeamViewer.



### APPLICATION AREAS OF MURTFELDT'S RAM GUARDS

- Fitting out production halls to protect facilities near to forklift paths

---

- Wall and building protection (for example, shop-fitting, schools, sport facilities, and public buildings)

---

- Tray trolleys

---

- Industrial elevators

---

- Trolley storage

---

- Airports and railway stations

---

- Forklift fairing

---

- Cold stores, abattoirs, and warehouses

---

- Hospitals and care homes

---

- Food-processing enterprises

---

- Equipping transport trolleys

---

### ADVANTAGES OF RAM PROTECTION SOLUTIONS MADE FROM PLASTIC

- Production in accordance with your individual requirements

---

- Even small batches are possible

---

- Production in accordance with drawings or samples – made by you or by us

---

- Free advice regarding plastic selection, design appropriate for plastics, and all questions about the application of our plastics

---

- Depending on the used plastic: Extremely impact-resistant, high durability unlike solutions made from metal or wood, no water absorption, physiologically safe (FDA), good slide properties, low material wear, and cost-effective

---





# QUALITY MANAGEMENT

**By quality management, we do not only mean the stringent assurance of quality in the Production department. For us, quality management also encompasses the personal responsibility of all employees in all corporate divisions to do a quality job.**

## QUALITY IS WHEN THE CUSTOMER COMES BACK – NOT THE PRODUCT!

Each Murtfeldt product is subjected to checks to make sure that it has been correctly produced prior to delivery. Our quality assurance staff are not solely responsible for ensuring that the material, quantity, dimensions, and tolerances of a product are correct. In addition, each work piece is subjected to a second check in line with our dual control principle. In line with our employee self-monitoring principle, each employee at our production centre is responsible for carrying out a quality check right after completing his or her order-related task. The employee in question and a colleague then sign to confirm that the task has been carried out correctly.

In the case of products that are particularly challenging from a technical point of view, quality assurance employees will carry out an additional final check with documentation at the request of the customer. Our quality standards are based on a quality

assurance system that was again certified in accordance with DIN ISO 9001 in 2013.

This QA system guarantees that our customers receive a constantly high level of qualified, optimized advice and services - from all contact partners and in all areas. This holds true whether you are looking for advice or placing an order, talking with in-house personnel or field staff, conducting joint developments of new constructions with our Application Technology department, or making a customer complaint. Our employees receive optimal training in accordance with DIN ISO stipulations and use tried and tested procedures to advise you. Ongoing training courses keep them on their toes. We believe that interaction should always leave room for the personal touch. Thus, our quality assurance team always takes customer requirements into account when creating process descriptions. This is in our interests as well as in yours.

### Quality Management Certificates

- Quality Management System DIN EN ISO 9001:2015
- Quality Management IQNet



## ENVIRONMENTAL AND ENERGY MANAGEMENT SYSTEM

### Our world is green

Murtfeldt's philosophy is written in green. This is not only because our traditional plastic, Original Material „S“® green, dominates our daily business; it is primarily because of our willingness to carry out all business activities within the framework of an environmentally friendly concept. Murtfeldt is aware of its obligation to protect the environment, a task which is gladly undertaken by the company. We believe that a company should have a spiritual and social value to its surrounding environment in addition to its economic worth. Taking responsibility for one's environment in no way conflicts with economic success.

Statutory norms help companies to find their way through a multitude of regulations. Murtfeldt is well ahead of most norms. For example, as early as 1997, we implemented an environmental management system in accordance with DIN EN ISO 14001. In practical terms, this means the following: During production, chippings are collected up and then processed at our Murdotec subsidiary to produce semi-finished products of a defined quality that are returned to Murtfeldt's production lines.

The purchasing of new machines is also subject to strict environmental criteria. Furthermore, the solar panels on the roof of the company's premises prove our commitment to the environment: In addition to using energy, at Murtfeldt we also generate it. In 2015, the company produced an impressive 151,000 kilowatt hours.

We take our commitment to the environment seriously: As a result of our company's efficient use of resources and sustained consideration of the environment, Murtfeldt was awarded Dortmund's ÖKOPROFIT award already in 2006. For us, this indicates the consistent continuation of our environmental and energy management philosophy.

### Quality Management Certificates

---

■ Environmental Management System  
DIN EN ISO 14001:2015

---

■ Energy management system  
DIN EN ISO 50001:2011

---





## CHAIN, BELT AND SLIDING GUIDES

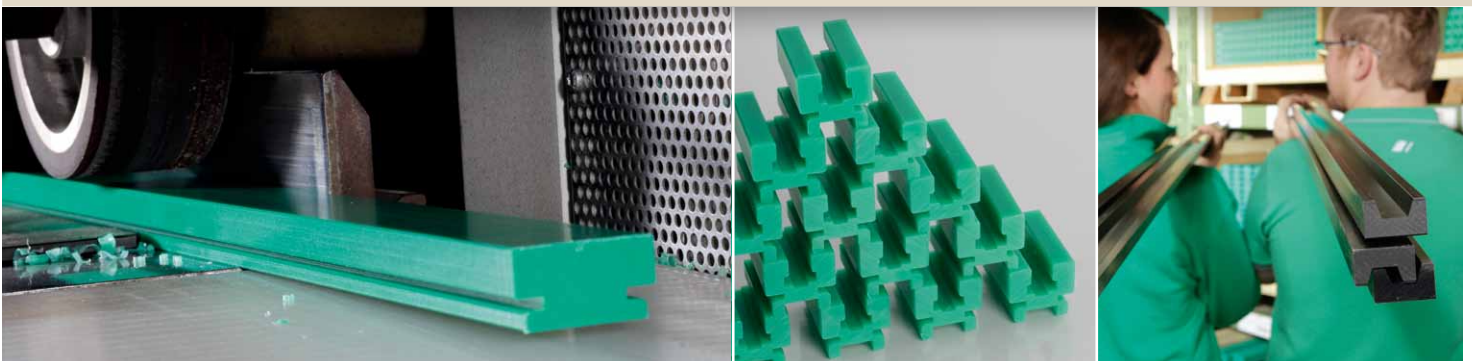



## CHAIN, BELT, AND SLIDING GUIDES – TABLE OF CONTENTS

Introduction	<b>64</b>
Overview of Chain Guides	<b>65</b>
Special Profiles	<b>66 – 67</b>
Chain, Belt, and Sliding Guides	<b>68</b>
Construction with Plastic Guides	<b>69</b>
Steel C Profiles	<b>70</b>
Selection Table for Steel C Profiles	<b>71</b>
Fastening of Steel C Profiles	<b>72</b>
T-Head Bolts	<b>73</b>
Fixing the Steel C-Profile with stud welding bolts	<b>74</b>
Chain Guides for Roller Chains as per DIN 8187	<b>75 – 91</b>
Types: T, CT, T-Duplex, CT-Duplex, T-Triplex, CT-Triplex, TU, CTU, TS, CTS, U, CU, K, CK, CKG, CKG 14H, CKG 15V, ETA	
Chain Guides for Round Link Chains as per DIN 766/764	<b>92 – 93</b>
Types: R, CRU, CRG, CRO	
Overview of Belt Guides/Belt Guides	<b>94 – 99</b>
Types: RR, RRC, KR, KRC, FR, FRC, FK, FKC	
Chain Racks	<b>100</b>
Profiles for Conveying and Transportation	<b>101 – 109</b>
Sliding Guides, Type CF, Rail guides as insertion and Clip Profiles, Bands, Slip-On Profiles, Profiles for Slat Band Chains, Curve Guides for Slat Band Chains	
Guides for modular belts	<b>110 – 112</b>

# OVERVIEW OF CHAIN GUIDES

For roller chains (DIN 8187) and round link chains (DIN 766/764)

Murtfeldt offers an extensive standard range of guides for roller chains. We have a total of 20 different types of guide for roller chains and four for round link chains. You can also choose between our high-quality Original Material "S"<sup>®</sup> green and our more economical Material "S"<sup>®</sup> 1000 green.

## Chain guides for roller chains as per DIN 8187 (DIN 8188 catalogue on request)

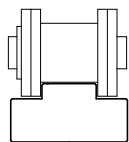

Type T – page 75

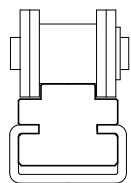

Type CT – page 76

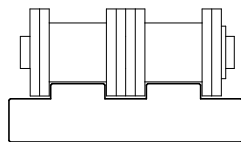

Type T-Duplex – page 77

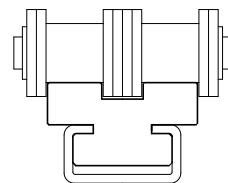

Type CT-Duplex – page 78

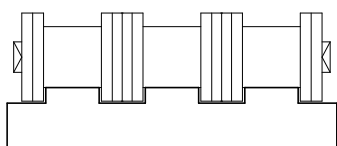

Type T-Triplex – page 79

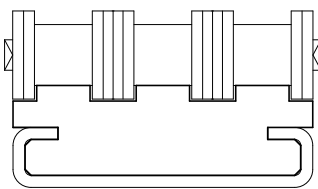

Type CT-Triplex – page 80

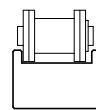

Type TU – page 81

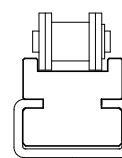

Type CTU – page 81

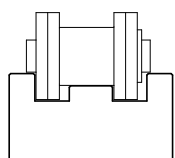

Type TS – page 82

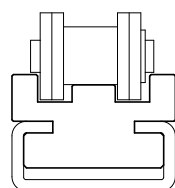

Type CTS – page 83

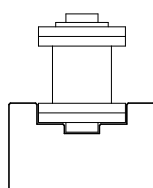

Type U – page 84

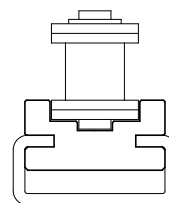

Type CU – page 85

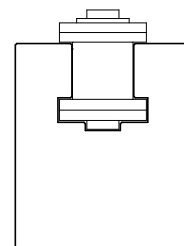

Type K – page 86

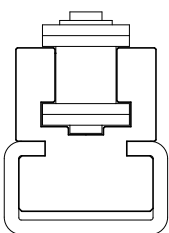

Type CK – page 87

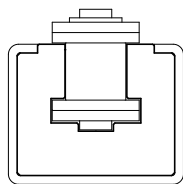

Type CKG – page 88

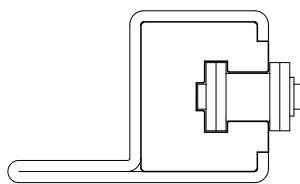

Type CKG 14H – page 89

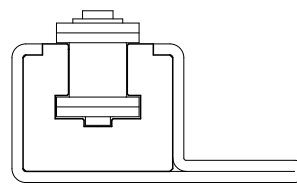

Type CKG 15V – page 90

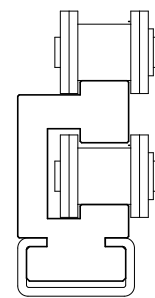

Type ETA – page 91

## Chain guides for round link chains as per DIN 766/764

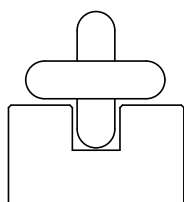

Type R – page 92

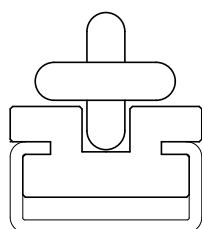

Type CRU – page 92

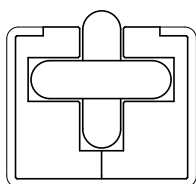

Type CRG – page 93

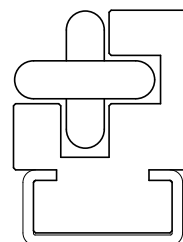

Type CRO – page 93

## SPECIAL PROFILES

When the standard designs are not enough

Our standard range of profiles offers many solutions for equipping your machines. Should we not have the design you require in our range, we would be happy to manufacture it to your individual specification. Get in touch with our application engineers or our Field Sales team.

We can also offer you the option of processing documents and drawings online and in real time together with our staff.

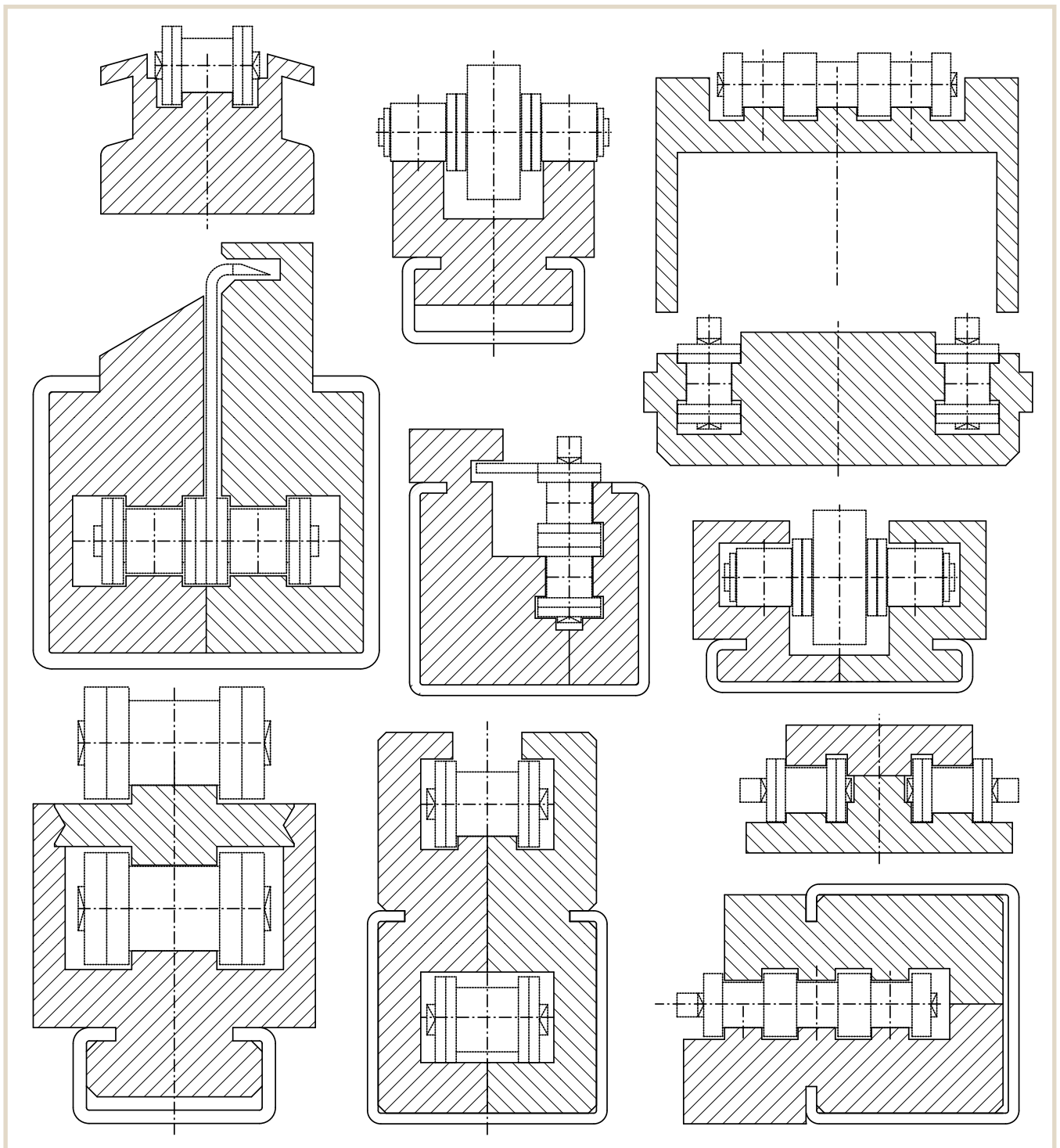

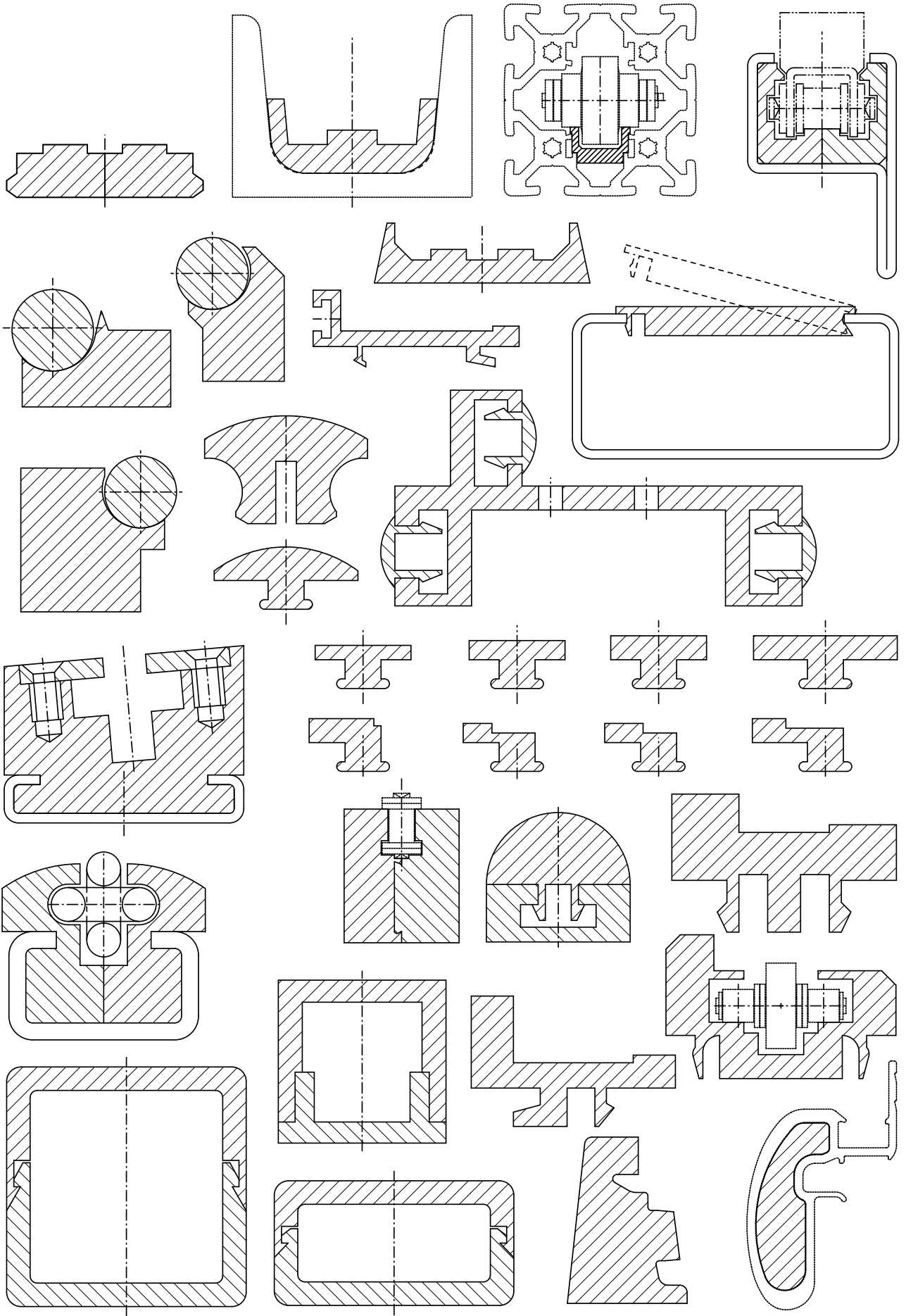



# CHAIN, BELT, AND SLIDING GUIDES

## Chain guides

Where there is friction, there is wear. This is especially the case for applications where metallic materials are used. For example, for chains that run on metal guides, regular lubrication is absolutely vital. The aim is to achieve quiet, smooth running and long-term functional reliability.

Murtfeldt chain guides protect your chains. They guarantee optimum running properties at the same time as extremely high wear resistance. The tried-and-tested Material "S"<sup>®</sup> and the economical alternative "S"<sup>®</sup>1000 have ideal material properties that make them well-suited for use as guides for roller and round link chains.

## Stock and individual production

Our warehouse stocks an extensive range of guides for roller chains that comply with DIN 8187 and round link chains that comply with DIN 766 and DIN 764.

In addition, we can manufacture economical and reliable special guides in accordance with your specifications – even in small lot sizes.

## Advantages of Murtfeldt chain guides

- High wear resistance
- Very good slide properties
- Self-lubricating (no need for any oil lubrication at all)
- Extremely impact and break resistant, even at very low temperatures (up to -250°C)
- High chemical resistance
- Vibration-reducing properties
- No moisture absorption
- No corrosion
- Approved for use in the food industry – EU and FDA (Original Material "S"<sup>®</sup> [FS])

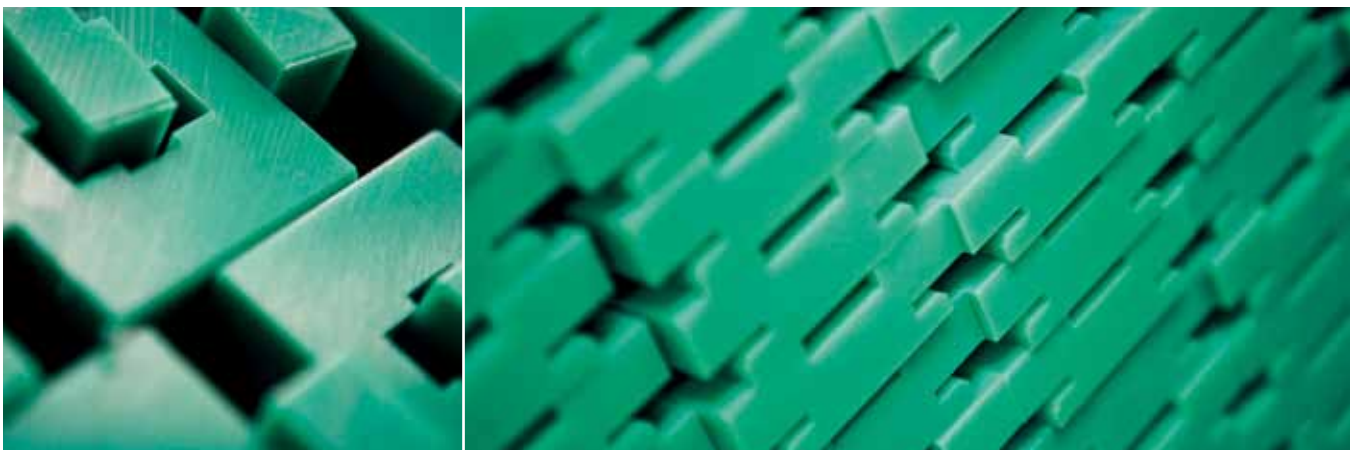

## CONSTRUCTION WITH PLASTIC GUIDES

Construction using thermoplastics requires careful consideration beforehand. The conditions of use have a direct influence on the material selection and design of the plastic guides. You should answer the following questions in advance:

- 
- To what static and dynamic loads will the guide be exposed?

---

  - To what environmental factors, such as chemicals, hot or cold water, steam, or contaminants will the material be exposed?

---

  - Will there be direct contact with foods?

---

  - How high is the working temperature?

---

  - How is the guide to be attached to a C profile (screwed on or inserted)?

---

In comparison with metallic materials, thermoplastics have a higher coefficient of linear thermal expansion.

### Calculation

When calculating the expansion, the anticipated difference between the assembly and minimum and maximum working temperatures is to be taken into account. The coefficient of linear thermal expansion of the material is used to precisely calculate the maximum elongation when the temperature rises and the reduction when the temperature drops (see formula below). The required movement space for the material can thus be taken into account before installation takes place. There are different fastening options depending on the application.

#### Formula for calculating elongation

$$\Delta L = L \times \alpha \times \Delta T$$

$\Delta L$  = Elongation

$L$  = Initial length

$\alpha$  = Coefficient of linear thermal expansion

$\Delta T$  = Temperature difference in °C



# STEEL C PROFILES

Regardless of the fastening method chosen, you should design your plant so that the material can expand. The easiest and most efficient fastening method is to fasten the guide using our steel C profiles. Unlike metals, thermoplastics are particularly predisposed to an increase/reduction in length when temperature variations occur. Mounting a guide in a steel C profile makes sense because of the freedom of movement afforded to the slide bar. This method also makes it easy to replace plastic guides. Steel C profiles also act as stable fasteners and can be welded or screwed on as required. We recommend the use of DIN screws or special assembly using T-head bolts (see page 66). We also offer fixing of steel C profiles with stud welding bolts.

## AVAILABLE VARIANTS

- Galvanized (Stocked)
- Stainless steel (Stocked)
- Untreated/nongalvanized (upon request)

## The advantages of Murtfeldt steel C profiles

- Simple assembly/disassembly of the guide system
- Quick replacement procedure if wear occurs
- Plastic profiles only need to be secured against being pushed out once
- Simple alignment of the guide system
- No distortion occurs when mounting the steel C profile if screws are used
- Guide can increase/decrease in length if temperature variations occur

## Single or varying chain/belt/cargo direction

When expansion takes place, the plastic guide moves up in the opposite direction to the running/conveying direction. You should therefore make sure that sufficient space for the anticipated expansion is provided at the start of the plastic guide.

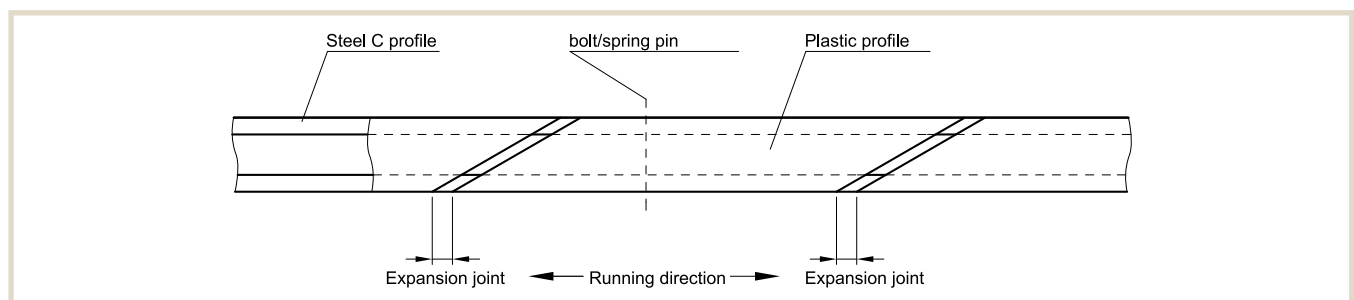
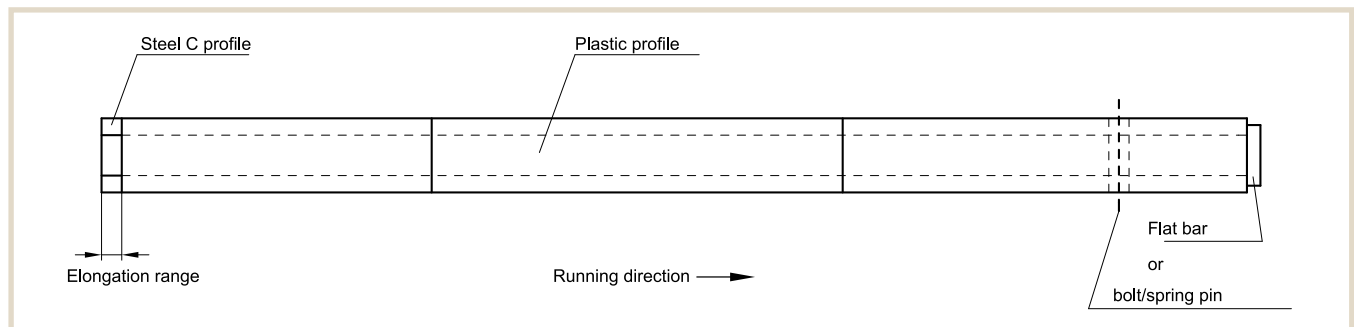

# SELECTION TABLE

Galvanized, untreated/nongalvanized or stainless steel C profiles

Profile No.	B	H	b	s	L	Length	Article no. galvanized	Article no. stainless steel	Article no. nongalvanized
C1	24	5.2	17.5	1	-	2000	351 020 001	351 020 101	
						3000	351 030 001	351 030 101	
						6000	351 060 001	351 060 101	
C3	20	10	10	1.5	-	2000	351 020 003	351 020 103	
						3000	351 030 003	351 030 103	
						6000	351 060 003	351 060 103	351 060 203
C4	50	10	35	2	-	2000	351 020 004	351 020 104	
						6000	351 060 004	351 060 104	
C5	28	12	14	2	-	2000	351 020 005	351 020 105	
						3000	351 030 005	351 030 105	
						6000	351 060 005	351 060 105	351 060 205
C6	80	10	65	2	-	2000	351 020 006	351 020 106	
						6000	351 060 006	351 060 106	
C7	28	16	14	2.5	-	2000	351 020 007	351 020 107	
						6000	351 060 007	351 060 107	351 060 207
C9	38	18	22	2.5	-	2000	351 020 009	351 020 109	
						3000	351 030 009	351 030 109	
						6000	351 060 009	351 060 109	351 060 209
C10	30	24	20	1.5	-	2000	351 020 010	351 020 110	
						6000	351 060 010	351 060 110	351 060 210
C11	45	40	31	2	-	2000	351 020 011	351 020 111	
						6000	351 060 011	351 060 111	351 060 211
C12	60	20	36	2.5	-	2000	351 020 012	351 020 112	
						6000	351 060 012	351 060 112	
C13	65	55	40	3	-	2000	351 020 013	351 020 113	
						6000	351 060 013	351 060 113	
C14 H	31	25	20	2	47	2000	351 020 014	351 020 114	
						3000	351 030 014	351 030 114	
						6000	351 060 014	351 060 114	
C15 V	31	25	20	2	53	2000	351 020 015	351 020 115	
						3000	351 030 015	351 030 115	
						6000	351 060 015	351 060 115	

Dimensions in mm

## C 14H and C 15V steel profiles with punch hole in mounting rail

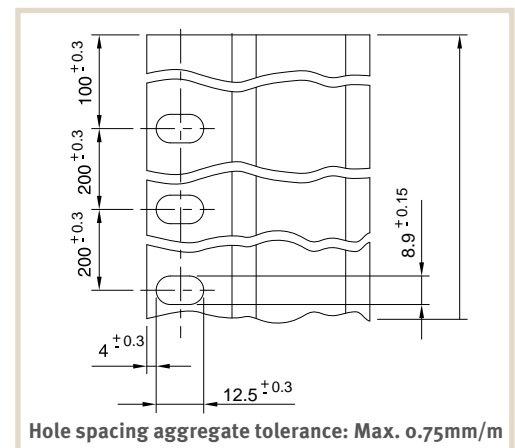
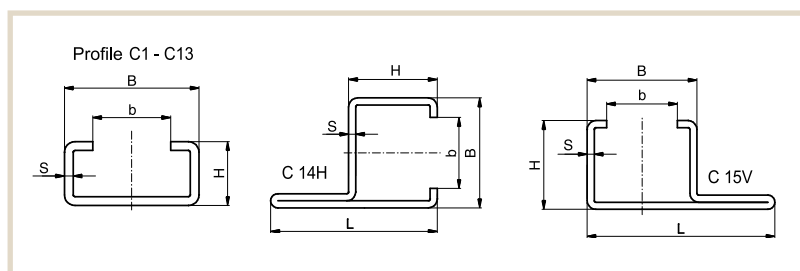



# FASTENING OF STEEL C PROFILES

## With T-head bolts

T-head bolts provide a secure connection between your machine element and our C profiles. As a rule, a simplex connection is used. Duplex connections are available if desired. Our application technology department will be glad to advise you to ensure that you obtain the best implementation for your requirements.

We can bore or punch individual hole patterns if you provide us with an appropriate drawing. For T-head bolt dimensions, see the following page.

---

■ Milled groove for bolt head prevents simultaneous turning of T-head bolt

---

■ Fastening of screw nuts from below (with T-head bolts)

---

■ Punching and boring of required hole pattern in accordance with individual drawings

---

### One-track fastening (standard)

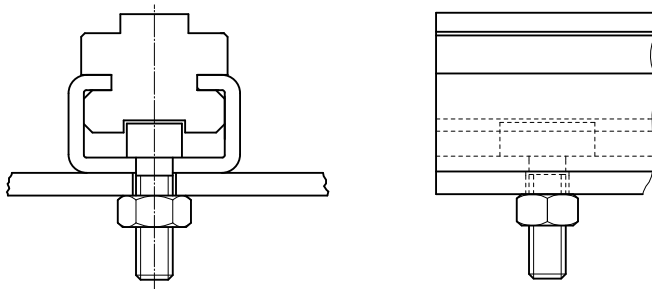

### Two-track fastening

(optional for wide C6 and C12 profiles)

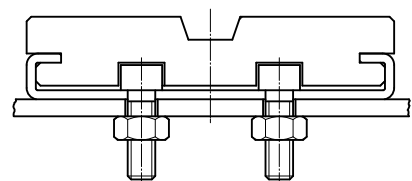

# T-HEAD BOLTS

Galvanized/stainless steel

Thread (M x L)	Suitable for these steel C profiles	A in mm	B in mm	h in mm	Material	Article no.	Type
M6x20	C1, C3, C4, C5, C6, C7, C9, C10, C11, C12, C13	18.0	9.5	4	galvanized	352010001	-
M6x20	C1, C4, C5, C6, C7, C9, C12	15.5	9.0	6	galvanized	352010005	20/12
M6x30	C1, C4, C5, C6, C7, C9, C12	15.5	9.0	6	galvanized	352010003	20/12
M6x40	C1, C4, C5, C6, C7, C9, C12	15.5	9.0	6	galvanized	352010004	20/12
M8x20	C4, C6, C7, C9, C12	15.5	9.0	6	galvanized	352010008	20/12
M8x30	C4, C6, C7, C9, C12	15.5	9.0	6	galvanized	352010006	20/12
M8x40	C4, C6, C7, C9, C12	15.5	9.0	6	galvanized	352010007	20/12
M8x20	C4, C6, C7, C9, C12	23.0	11.0	6	galvanized	352010011	28/15
M8x30	C4, C6, C7, C9, C12	23.0	11.0	6	galvanized	352010019	28/15
M8x40	C4, C6, C7, C9, C12	23.0	11.0	6	galvanized	352010014	28/15
M10x20	C4, C6, C7, C9, C11, C12, C13	23.0	11.0	7	galvanized	352010020	28/15
M10x30	C4, C6, C7, C9, C11, C12, C13	23.0	11.0	7	galvanized	352010012	28/15
M10x40	C4, C6, C7, C9, C11, C12, C13	23.0	11.0	7	galvanized	352010013	28/15
M10x20	C6, C9, C12	31.0	13.5	9	galvanized	352010015	38/17
M10x30	C6, C9, C12	31.0	13.5	9	galvanized	352010016	38/17
M12x40	C6, C11, C12, C13	31.0	13.5	9	galvanized	352010017	38/17
M6x20	C1, C3, C4, C5, C6, C7, C9, C10, C11, C12, C13	18.0	9.5	4	stainless steel	352010002	-
M8x20	C4, C6, C7, C9, C12	15.5	9.0	6	stainless steel	352010025	20/12
M8x30	C4, C6, C7, C9, C12	15.5	9.0	6	stainless steel	352010026	20/12

Please speak with our application technology department to determine the best T-head screw for your needs. We can provide the appropriate models including nuts for one-track and two-track connections.

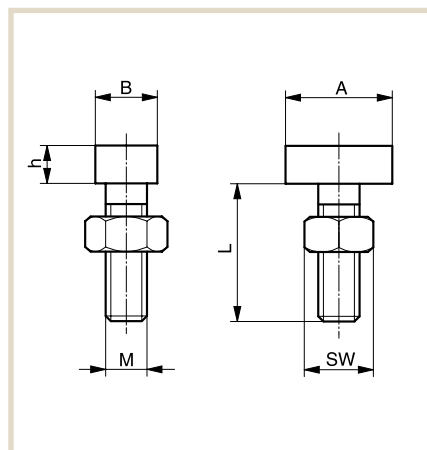

# FIXING THE STEEL C-PROFILE WITH STUD WELDING BOLTS TECHNOLOGY



- Individual fixing of the welded bolt to your specification at any position on the steel-C-profile
- Cost-effective process as no need for complex preparatory work
- Available for galvanized and stainless steel profiles
- Threaded bolts up to M8
- Max. bolt length 40 mm

Thread size	Length	Material
M4	12	stainless steel
M5	8	stainless steel
M5	20	stainless steel
M5	20	steel
M6	25	stainless steel
M6	25	steel
M8	15	stainless steel
M8	15	steel
M8	20	stainless steel
M8	20	steel
M8	30	stainless steel
M8	30	steel

Other dimensions on request.

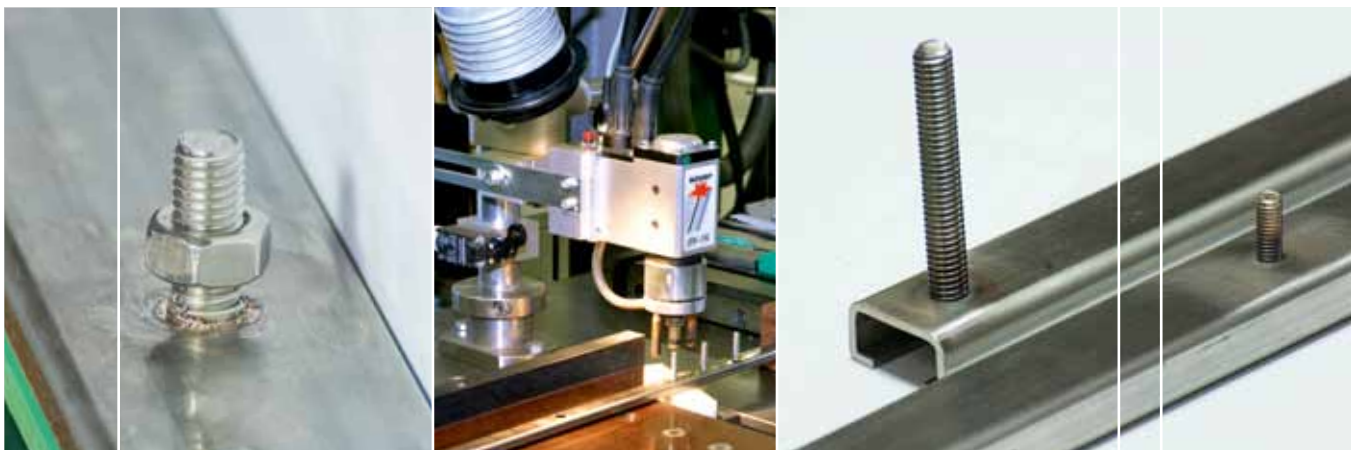

# Chain Guides for Roller Chains as per DIN 8187

## TYPE T



DIN 8187 chain no.	Chain dimensions in inches	B	H	b	h	Article no.
06B-1	3/8" x 7/32"	15	10	5,4	1,5	221 010 002
083-1	1/2" x 3/16"	15	10	4,5	1,5	221 010 003
085-1	1/2" x 1/4"	20	10	6,2	2,2	221 010 004
08B-1	1/2" x 5/16"	20	10	7,4	2,2	221 010 005
08B-1	1/2" x 5/16"	20	15	7,4	2,2	221 010 006
08B-1	1/2" x 5/16"	20	20	7,4	2,2	221 010 007
08B-1	1/2" x 5/16"	20	30	7,4	2,2	221 010 008
-	5/8" x 1/4"	20	10	6,2	2,6	221 010 009
10B-1	5/8" x 3/8"	20	10	9,3	2,6	221 010 010
10B-1	5/8" x 3/8"	20	15	9,3	2,6	221 010 011
10B-1	5/8" x 3/8"	20	20	9,3	2,6	221 010 012
10B-1	5/8" x 3/8"	20	30	9,3	2,6	221 010 013
12B-1	3/4" x 7/16"	25	10	11,3	2,4	221 010 014
12B-1	3/4" x 7/16"	25	15	11,3	2,4	221 010 015
12B-1	3/4" x 7/16"	25	20	11,3	2,4	221 010 016
12B-1	3/4" x 7/16"	25	30	11,3	2,4	221 010 017
16B-1	1" x 17 mm	40	15	16,0	3,5	221 010 018
16B-1	1" x 17 mm	40	20	16,0	3,5	221 010 019
16B-1	1" x 17 mm	40	30	16,0	3,5	221 010 020
20B-1	1 1/4" x 3/4"	45	15	18,0	4,2	221 010 021
24B-1	1 1/2" x 1"	60	15	24,0	5,5	221 010 022
28B-1	1 3/4" x 31 mm	75	20	30,0	6,8	221 010 023
32B-1	2" x 31 mm	80	20	30,0	7,7	221 010 024

Dimensions in mm - Separate ASA/JIS product catalogue available.

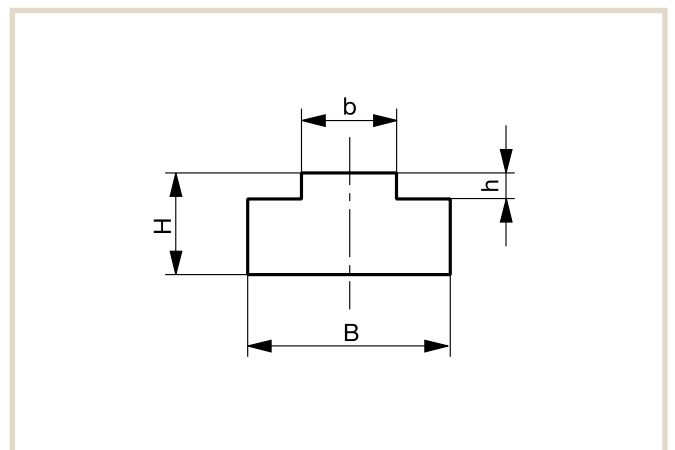



# TYPE CT



DIN 8187 chain no.	Chain dimensions in inches	C profile type	B1	B2	H	Hc	b	h	Article no.
06B-1	3/8" x 7/32"	C3	17	20	14	17	5.4	1.5	221 210 015 351 020 003
083-1	1/2" x 3/16"	C3	17	20	14	17	4.5	1.5	221 210 002 351 020 003
085-1	1/2" x 1/4"	C3	17	20	14	17	6.2	2.2	221 210 003 351 020 003
08B-1	1/2" x 5/16"	C1	20	24	10	11	7.4	2.2	221 210 001 351 020 001
08B-1	1/2" x 5/16"	C3	17	20	14	17	7.4	2.2	221 210 004 351 020 003
-	5/8" x 1/4"	C3	17	20	14	17	6.2	2.6	221 210 005 351 020 003
10B-1	5/8" x 3/8"	C3	17	20	14	17	9.3	2.6	221 210 006 351 020 003
12B-1	3/4" x 7/16"	C3	20	20	14	17	11.3	2.4	221 210 007 351 020 003
12B-1	3/4" x 7/16"	C5	24	28	14	18	11.3	2.4	221 210 008 351 020 005
16B-1	1" x 17 mm	C5	24	28	14	18	16	3.5	221 210 009 351 020 005
20B-1	1 1/4" x 3/4"	C5	28	28	14	18	18	4.2	221 210 010 351 020 005
24B-1	1 1/2" x 1"	C9	33	38	23	30	24	5.5	221 210 011 351 020 009
28B-1	1 3/4" x 31 mm	C9	38	38	23	30	30	6.8	221 210 012 351 020 009
32B-1	2" x 31 mm	C9	38	38	23	30	30	7.7	221 210 013 351 020 009
32B-1	2" x 31 mm	C12	60	60	25	35	30	7.7	221 210 014 351 020 012

Dimensions in mm - Separate ASA/JIS product catalogue available.

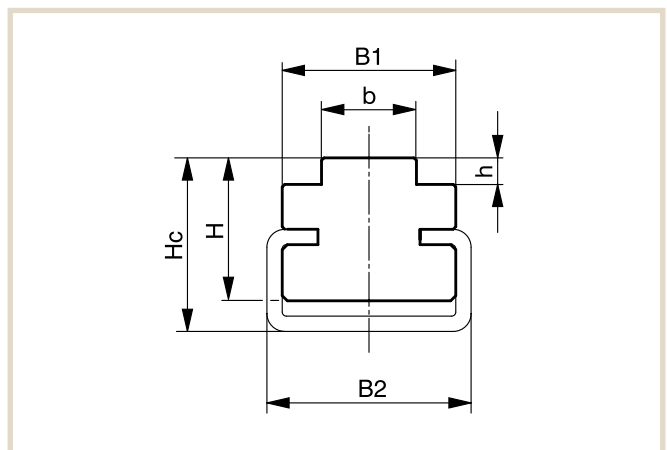

# TYPE T-DUPLEX



DIN 8187 chain no.	Chain dimensions in inches	B	H	b	h	e+b	Article no.
06B-2	3/8" x 7/32"	25.0	10	5.3	1.5	15.6	221 010 025
08B-2	1/2" x 5/16"	35.0	10	7.2	2.2	21.2	221 010 026
08B-2	1/2" x 5/16"	35.0	15	7.2	2.2	21.2	221 010 027
08B-2	1/2" x 5/16"	35.0	20	7.2	2.2	21.2	221 010 028
08B-2	1/2" x 5/16"	35.0	30	7.2	2.2	21.2	221 010 029
10B-2	5/8" x 3/8"	40.0	10	9.0	2.6	25.6	221 010 030
12B-2	3/4" x 7/16"	45.0	15	10.9	2.4	30.4	221 010 031
12B-2	3/4" x 7/16"	45.0	10	10.9	2.4	30.4	221 010 032
16B-2	1" x 17 mm	47.8	15	15.8	3.5	47.8	221 010 033
20B-2	1 1/4" x 3/4"	54.7	15	18.2	4.2	54.7	221 010 034
24B-2	1 1/2" x 1"	72.0	20	23.6	5.5	72.0	221 010 035
28B-2	1 3/4" x 31 mm	88.4	25	28.8	6.8	88.4	221 010 036
32B-2	2" x 31 mm	87.4	30	28.8	7.7	87.4	221 010 037

Dimensions in mm - Separate ASA/JIS product catalogue available.

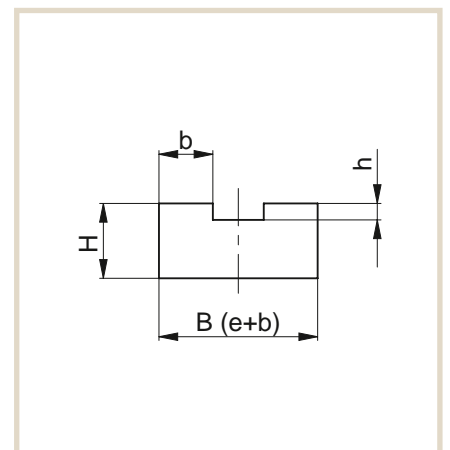
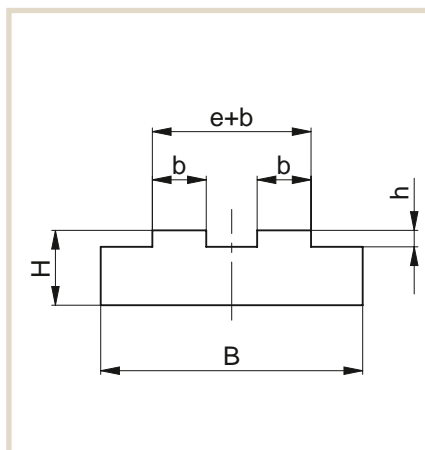

# TYPE CT-DUPLEX



DIN 8187 chain no.	Chain dimensions in inches	C profile type 	B1	B2	H	Hc	b	h	Article no.
06B-2	3/8" x 7/32"	C3	15.6	20	14	17	5.3	1.5	221 210 022 351 020 003
08B-2	1/2" x 5/16"	C3	21.2	20	14	17	7.2	2.2	221 210 016 351 020 003
10B-2	5/8" x 3/8"	C3	25.6	20	14	17	9.0	2.6	221 210 017 351 020 003
12B-2	3/4" x 7/16"	C5	30.4	28	15	20	10.9	2.4	221 210 018 351 020 005
16B-2	1" x 17 mm	C9	47.8	38	20	27	15.8	3.5	221 210 019 351 020 009
20B-2	1 1/4" x 3/4"	C12	54.7	60	22	30	18.2	4.2	221 210 020 351 020 012
24B-2	1 1/2" x 1"	C12	72.0	60	25	35	23.6	5.5	221 210 021 351 020 012

Dimensions in mm - Separate ASA/JIS product catalogue available.

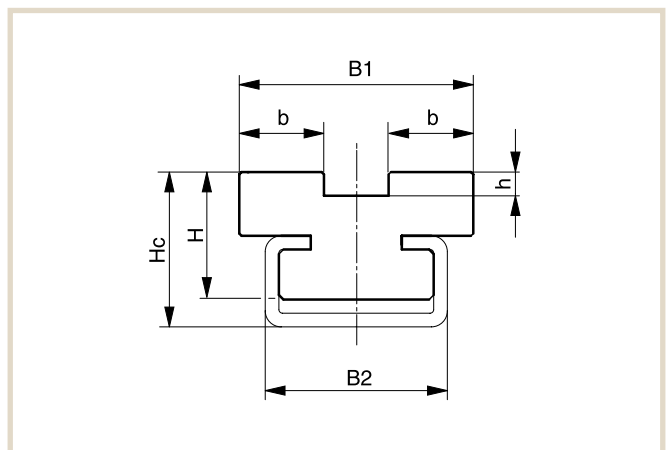
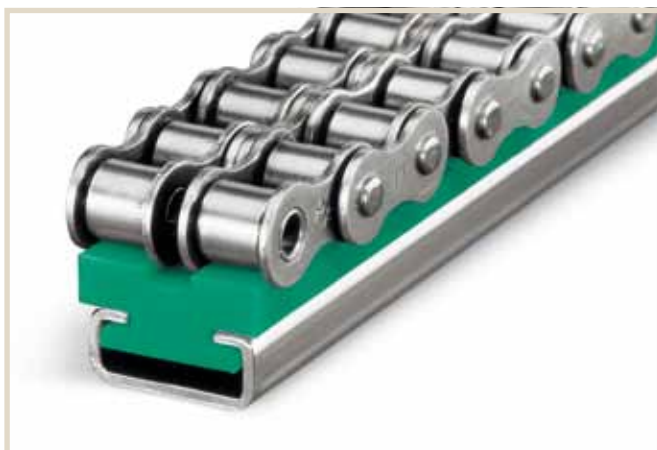

# TYPE T-TRIPLEX



DIN 8187 chain no.	Chain dimensions in inches	B	H	b	h	2e+b	Article no.
06B-3	3/8" x 7/32"	35.0	10	5.3	1.5	25.9	221 010 038
08B-3	1/2" x 5/16"	45.0	10	7.1	2.2	34.9	221 010 039
10B-3	5/8" x 3/8"	55.0	10	8.9	2.6	42.1	221 010 040
12B-3	3/4" x 7/16"	60.0	15	10.7	2.4	49.7	221 010 041
16B-3	1" x 17 mm	79.5	20	15.7	3.5	79.5	221 010 042
20B-3	1 1/4" x 3/4"	91.0	20	18.0	4.2	91.0	221 010 043
24B-3	1 1/2" x 1"	120.0	25	23.4	5.5	120.0	221 010 044

Dimensions in mm - Separate ASA/JIS product catalogue available.

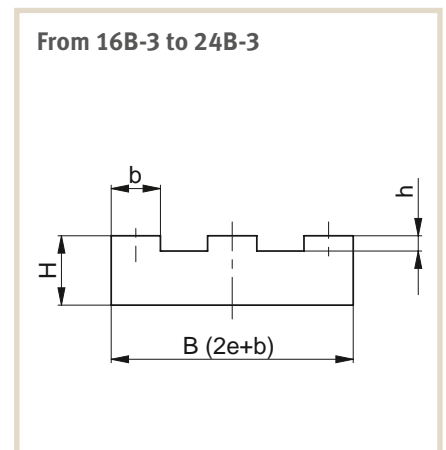
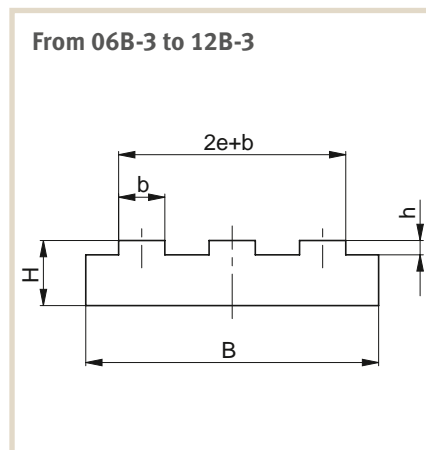



# TYPE CT-TRIPLEX



DIN 8187 chain no.	Chain dimensions in inches	C profile type 	B1	B2	H	Hc	b	h	2e + b	Article no.
06B-3	3/8" x 7/32"		30.0		15	20	5.3	1.5	25.9	221 210 023
		C5		28						351 020 005
08B-3	1/2" x 5/16"		34.9		15	20	7.1	2.2	34.9	221 210 024
		C5		28						351 020 005
10B-3	5/8" x 3/8"		50.0		15	17	8.9	2.6	42.1	221 210 025
		C4		50						351 020 004
12B-3	3/4" x 7/16"		49.7		18	20	10.7	2.4	49.7	221 210 026
		C4		50						351 020 004
16B-3	1" x 17 mm		79.5		20	22	15.7	3.5	79.5	221 210 027
		C6		80						351 020 006
20B-3	1 1/4" x 3/4"		91.0		20	22	18.0	4.2	91.0	221 210 028
		C6		80						351 020 006

Dimensions in mm - Separate ASA/JIS product catalogue available.

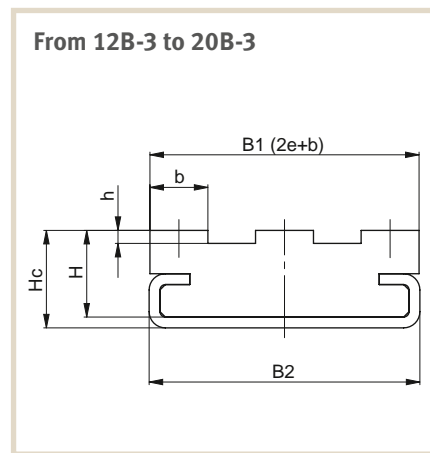
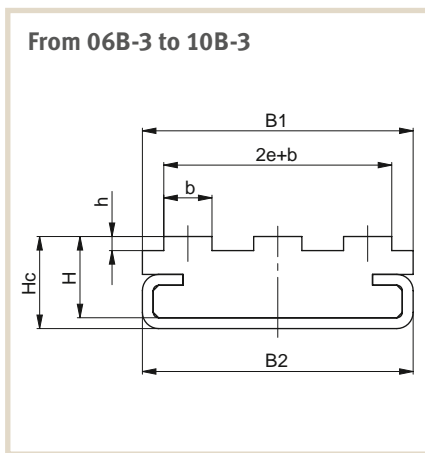

# TYPE TU



DIN 8187 chain no.	Chain dimensions in inches	B	H	b	h	Article no.
-	3/8" x 5/32"	15	10	12	2.2	221 110 010
083-1	1/2" x 3/16"	15	10	12	2.2	221 110 011

Dimensions in mm · Separate ASA/JIS product catalogue available.

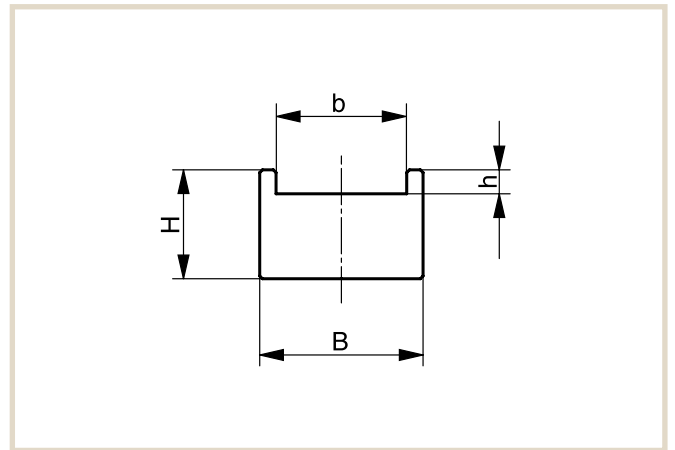

# TYPE CTU



DIN 8187 chain no.	Chain dimensions in inches	C profile type	B1	B2	H	Hc	b	h	Article no.
-	3/8" x 5/32"	C3	17	20	14	17	12	2.2	221 310 010
									351 020 003
083-1	1/2" x 3/16"	C3	17	20	14	17	12	2.2	221 310 010
									351 020 003

Dimensions in mm · Separate ASA/JIS product catalogue available.

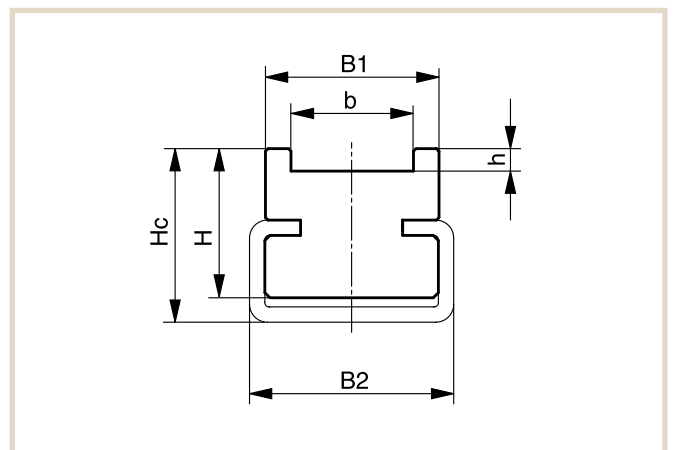

# TYPE TS



DIN 8187 chain no.	Chain dimensions in inches	B	H	b1	b2	h1	h2	Article no.
06B-1	3/8" x 7/32"	20	10	3.8	13.0	1.5	1.1	221 110 001
083-1	1/2" x 3/16"	20	10	3.0	12.4	1.6	1.4	221 110 002
085-1	1/2" x 1/4"	22	10	4.5	15.1	2.2	1.6	221 110 003
08B-1	1/2" x 5/16"	25	15	5.7	16.3	2.2	1.6	221 110 004
-	5/8" x 1/4"	25	15	4.1	16.1	2.6	2.1	221 110 005
10B-1	5/8" x 3/8"	28	15	7.4	19.2	2.6	2.1	221 110 006
12B-1	3/4" x 7/16"	30	20	9.2	21.8	2.4	2.8	221 110 007
16B-1	1" x 17 mm	42	25	15.0	35.0	3.5	3.3	221 110 008
20B-1	1 1/4" x 3/4"	50	25	16.8	40.0	4.2	4.0	221 110 009

Dimensions in mm · Separate ASA/JIS product catalogue available.

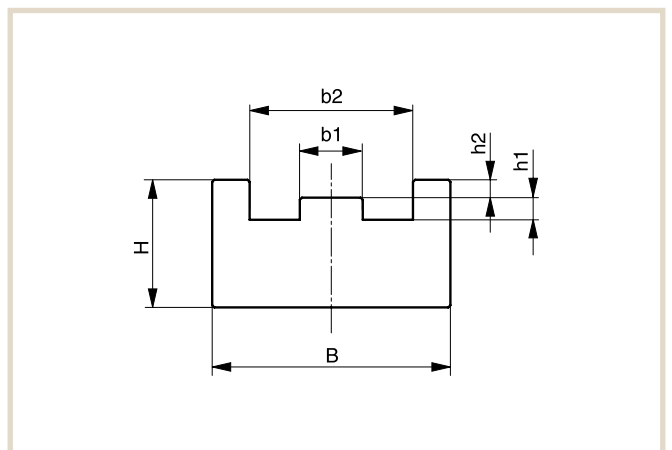

# TYPE CTS



DIN 8187 chain no.	Chain dimensions in inches	C profile type	B1	B2	H	Hc	b1	b2	h1	h2	Article no.
06B-1	3/8" x 7/32"	C3	20	20	14	17	3.8	13.0	1.5	1.1	221 310 001 351 020 003
083-1	1/2" x 3/16"	C3	20	20	14	17	3.0	12.4	1.6	1.4	221 310 002 351 020 003
085-1	1/2" x 1/4"	C3	22	20	14	17	4.5	15.1	2.2	1.6	221 310 003 351 020 003
08B-1	1/2" x 5/16"	C3	25	20	16	20	5.7	16.3	2.2	1.6	221 310 004 351 020 003
-	5/8" x 1/4"	C3	25	20	16	20	4.1	16.1	2.6	2.1	221 310 005 351 020 003
10B-1	5/8" x 3/8"	C5	28	28	16	20	7.4	19.2	2.6	2.1	221 310 006 351 020 005
12B-1	3/4" x 7/16"	C5	30	28	18	22	9.2	21.8	2.4	2.8	221 310 007 351 020 005
16B-1	1" x 17 mm	C9	42	38	25	30	15.0	35.0	3.5	3.3	221 310 008 351 020 009
20B-1	1 1/4" x 3/4"	C9	50	38	30	35	16.8	40.0	4.2	4.0	221 310 009 351 020 009

Dimensions in mm - Separate ASA/JIS product catalogue available.

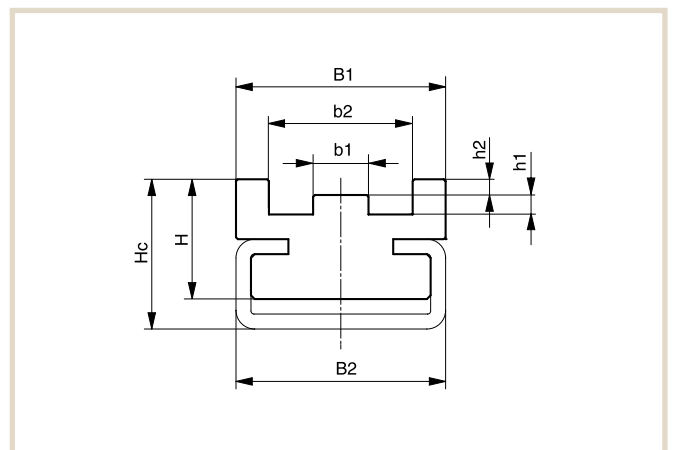



# TYPE U



DIN 8187 chain no.	Chain dimensions in inches	B	H	d2	g	h2	h3	Article no.
-	3/8" x 5/32"	20	15	4	9.4	2.8	4.2	221 110 012
06B-1	3/8" x 7/32"	20	15	4	9.4	2.8	4.2	221 110 013
083-1	1/2" x 3/16"	20	15	5	10.8	2.3	3.8	221 110 014
g=12,8mm	1/2" x 1/4"	25	15	5	12.8	3.5	5.0	221 110 015
08B-1	1/2" x 5/16"	25	15	5	12.8	3.5	5.0	221 110 017
-	5/8" x 1/4"	25	15	6	15.4	3.6	5.2	221 110 016
085-1	1/2 x 1/4"	20	15	5	11.8	3.2	4.7	221 110 018
10B-1	5/8" x 3/8"	25	15	6	15.4	3.6	5.0	221 110 019
12B-1	3/4" x 7/16"	25	20	7	17.0	3.9	5.7	221 110 020
16B-1	1" x 17 mm	33	25	10	24.0	8.4	10.6	221 110 021
20B-1	1 1/4" x 3/4"	55	25	11	28.0	10.0	12.2	221 110 022
24B-1	1 1/2" x 1"	60	30	16	36.6	13.0	16.0	221 110 023
28B-1	1 3/4" x 31 mm	65	30	17	40.0	16.0	18.0	221 110 024
32B-1	2" x 31 mm	70	30	20	44.6	16.0	20.0	221 110 025

Dimensions in mm · Separate ASA/JIS product catalogue available.

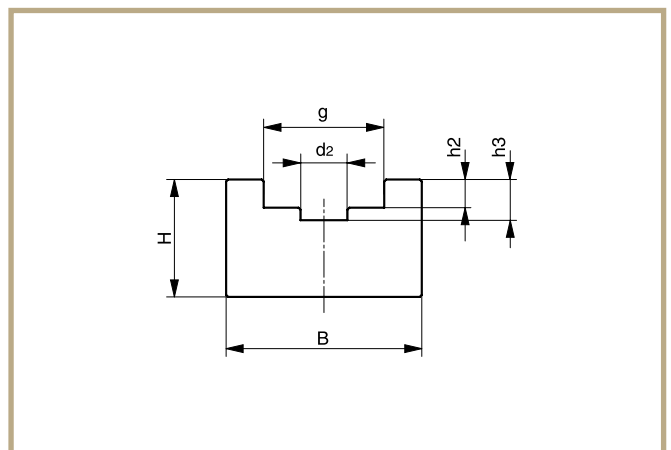

# TYPE CU



DIN 8187 chain no.	Chain dimensions in inches	C profile type	B1	B2	H	Hc	d2	g	h2	h3	Article no.
-	3/8" x 5/32"	C3	20	20	14	17	4	9.4	2.8	4.2	221 310 011 351 020 003
06B-1	3/8" x 7/32"	C3	20	20	14	17	4	9.4	2.8	4.2	221 310 013 351 020 003
083-1	1/2" x 3/16"	C3	20	20	14	17	5	10.8	2.3	3.8	221 310 015 351 020 003
085-1	1/2" x 1/4"	C5	28	28	14	18	5	11.8	3.2	4.7	221 310 017 351 020 005
g=12,8mm	1/2" x 1/4"	C5	28	28	14	18	5	12.8	3.5	5.0	221 310 019 351 020 005
08B-1	1/2" x 5/16"	C1	20	24	10	11	5	12.8	3.5	5.0	221 310 012 351 020 001
-	5/8" x 1/4"	C5	24	28	12	18	6	15.4	3.6	5.2	221 310 021 351 020 005
10B-1	5/8" x 3/8"	C5	24	28	12	18	6	15.4	3.6	5.0	221 310 014 351 020 005
12B-1	3/4" x 7/16"	C5	24	28	12	18	7	17.0	3.9	5.7	221 310 016 351 020 005
16B-1	1" x 17 mm	C9	33	38	20	30	10	24.0	8.4	10.6	221 310 018 351 020 009
20B-1	1 1/4" x 3/4"	C12	60	60	25	35	11	28.0	10.0	12.2	221 310 020 351 020 012
24B-1	1 1/2" x 1"	C12	60	60	30	40	16	36.6	13.0	16.0	221 310 022 351 020 012
28B-1	1 3/4" x 31 mm	C12	65	60	38	45	17	40.0	16.0	18.0	221 310 023 351 020 012
32B-1	2" x 31 mm	C12	70	60	38	45	20	44.6	16.0	20.0	221 310 024 351 020 012

Dimensions in mm · Separate ASA/JIS product catalogue available.

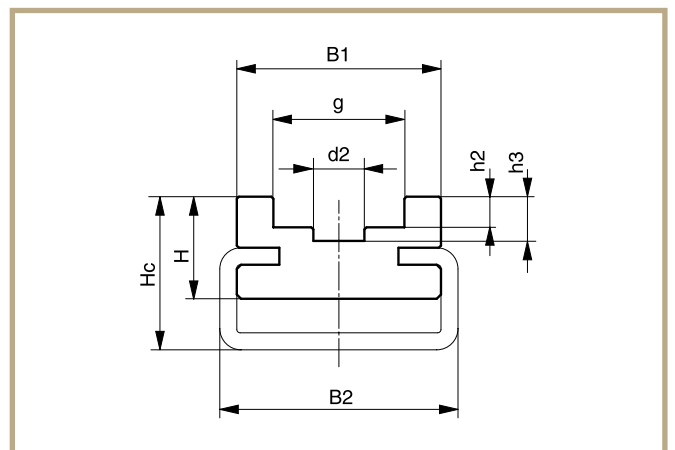

# TYPE K



DIN 8187 chain no.	Chain dimensions in inches	B	H	d1	d2	g	h1	h2	h3	Article no.
-	3/8" x 5/32"	20	25	6.6	4	9.4	3.6	7.0	8.0	221 110 026
06B-1	3/8" x 7/32"	20	25	6.6	4	9.4	5.5	8.9	10.0	221 110 027
083-1	1/2" x 3/16"	20	25	8.0	5	10.8	4.5	8.0	9.5	221 110 028
085-1	1/2" x 1/4"	24	30	8.0	5	11.8	6.2	9.8	11.3	221 110 029
g=12,8mm	1/2" x 1/4"	24	30	8.8	5	12.8	6.2	10.2	11.7	221 110 030
08B-1	1/2" x 5/16"	24	30	8.9	5	12.8	7.4	11.5	13.0	221 110 031
-	5/8" x 1/4"	30	30	10.6	6	15.4	6.2	10.2	11.6	221 110 032
10B-1	5/8" x 3/8"	30	35	10.6	6	15.4	9.3	13.5	14.9	221 110 033
12B-1	3/4" x 7/16"	40	35	12.4	7	17.0	11.3	15.9	17.5	221 110 034
16B-1	1" x 17 mm	40	45	16.4	10	24.0	16.0	25.7	27.7	221 110 035
20B-1	1 1/4" x 3/4"	50	50	20.0	11	28.0	18.0	29.5	31.7	221 110 036
24B-1	1 1/2" x 1"	60	60	27.0	16	36.6	24.0	38.2	41.2	221 110 037
28B-1	1 3/4" x 31 mm	60	70	30.0	17	41.0	30.0	47.0	49.0	221 110 038
32B-1	2" x 31 mm	70	75	31.0	19	44.6	30.0	47.3	50.0	221 110 039

Dimensions in mm - Separate ASA/JIS product catalogue available.

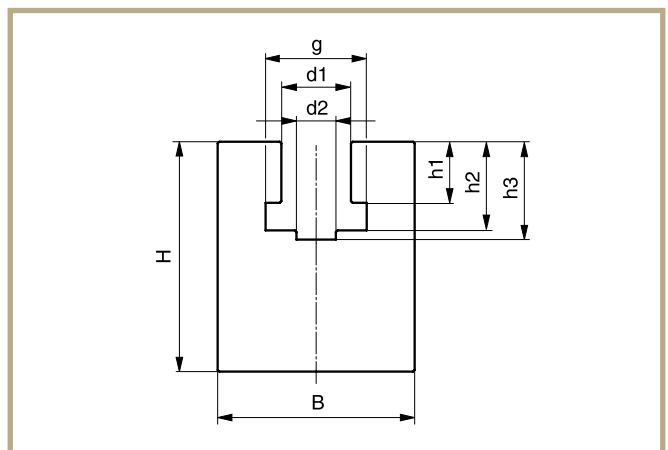

# TYPE CK



DIN 8187 chain no.	Chain dimensions in inches	C profile type	B1	B2	H	Hc	d1	d2	g	h1	h2	h3	Article no.
-	3/8" x 5/32"	C3	20	20	18	21	6.6	4	9.4	3.6	7.0	8.0	221 310 025 351 020 003
06B-1	3/8" x 7/32"	C3	20	20	18	21	6.6	4	9.4	5.5	8.9	10.0	221 310 026 351 020 003
083-1	1/2" x 3/16"	C3	20	20	18	21	8.0	5	10.8	4.5	8.0	9.5	221 310 027 351 020 003
085-1	1/2" x 1/4"	C7	24	28	28	32	8.0	5	11.8	6.2	9.8	11.3	221 310 028 351 020 007
g=12,8mm	1/2" x 1/4"	C7	24	28	28	32	8.8	5	12.8	6.2	10.2	11.7	221 310 029 351 020 007
08B-1	1/2" x 5/16"	C7	24	28	28	32	8.9	5	12.8	7.4	11.5	13.0	221 310 030 351 020 007
-	5/8" x 1/4"	C7	24	28	28	32	10.6	6	15.4	6.2	10.2	11.6	221 310 031 351 020 007
10B-1	5/8" x 3/8"	C7	24	28	28	32	10.6	6	15.4	9.3	13.5	14.9	221 310 032 351 020 007
12B-1	3/4" x 7/16"	C9	32	38	35	43	12.4	7	17.0	11.3	15.9	17.5	221 310 033 351 020 009
16B-1	1" x 17 mm	C9	40	38	45	50	16.4	10	24.0	16.0	25.7	27.7	221 310 034 351 020 009
20B-1	1 1/4" x 3/4"	C12	60	60	50	55	20.0	11	28.0	18.0	29.5	31.7	221 310 035 351 020 012
24B-1	1 1/2" x 1"	C12	60	60	60	65	27.0	16	36.6	24.0	38.2	41.2	221 310 036 351 020 012
28B-1	1 3/4" x 31 mm	C12	70	60	75	80	30.0	17	40.0	30.0	47.0	49.0	221 310 037 351 020 012
32B-1	2" x 31 mm	C12	70	60	75	80	31.0	19	44.6	30.0	47.3	50.0	221 310 038 351 020 012

Dimensions in mm - Separate ASA/JIS product catalogue available.

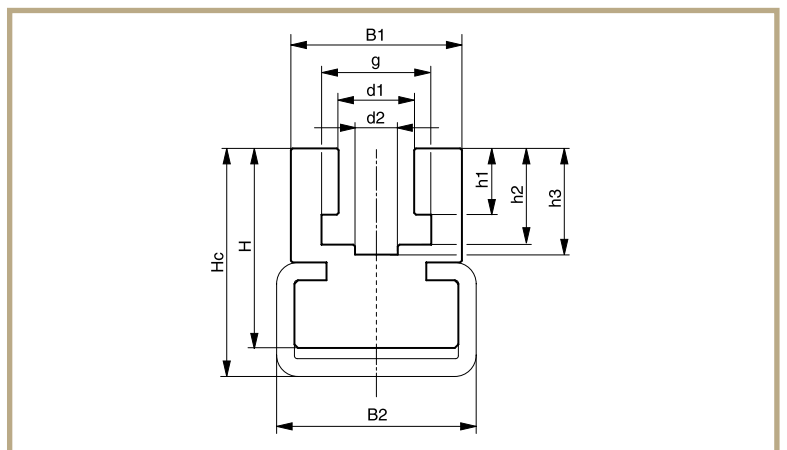



# TYPE CKG



DIN 8187 chain no.	Chain dimensions in inches	C profile type 	B	Hc	d1	d2	g	h1	h2	h3	Article no.
-	3/8" x 5/32"	C10	30	24	6.6	4	9.4	3.6	7.0	8.0	221 410 001 351 020 010
06B-1	3/8" x 7/32"	C10	30	24	6.6	4	9.4	5.5	8.9	10.0	221 410 002 351 020 010
083-1	1/2" x 3/16"	C10	30	24	8.0	5	10.8	4.5	8.0	9.5	221 410 003 351 020 010
085-1	1/2" x 1/4"	C10	30	24	8.0	5	11.8	6.2	9.8	11.3	221 410 020 351 020 010
g=12,8mm	1/2" x 1/4"	C10	30	24	8.8	5	12.8	6.2	10.2	11.7	221 410 021 351 020 010
08B-1	1/2" x 5/16"	C10	30	24	8.9	5	12.8	7.4	11.5	13.0	221 410 004 351 020 010
-	5/8" x 1/4"	C10	30	24	10.6	6	15.4	6.2	10.2	11.6	221 410 022 351 020 010
10B-1	5/8" x 3/8"	C10	30	24	10.6	6	15.4	9.3	13.5	14.9	221 410 005 351 020 010
12B-1	3/4" x 7/16"	C10	30	24	12.4	7	17.0	11.3	15.9	17.5	221 410 006 351 020 010
16B-1	1" x 17 mm	C11	45	40	16.4	10	24.0	16.0	25.7	27.7	221 410 007 351 020 011
20B-1	1 1/4" x 3/4"	C11	45	40	20.0	11	28.0	18.0	29.5	31.7	221 410 008 351 020 011
24B-1	1 1/2" x 1"	C13	65	55	27.0	16	36.6	24.0	38.2	41.2	221 410 009 351 020 013
28B-1	1 3/4" x 31 mm	C13	65	60	30.0	17	41.0	30.0	47.0	49.0	221 410 010 351 020 013
32B-1	2" x 31 mm	C13	65	60	31.0	19	44.6	30.0	47.3	50.0	221 410 011 351 020 013

Dimensions in mm - Separate ASA/JIS product catalogue available.

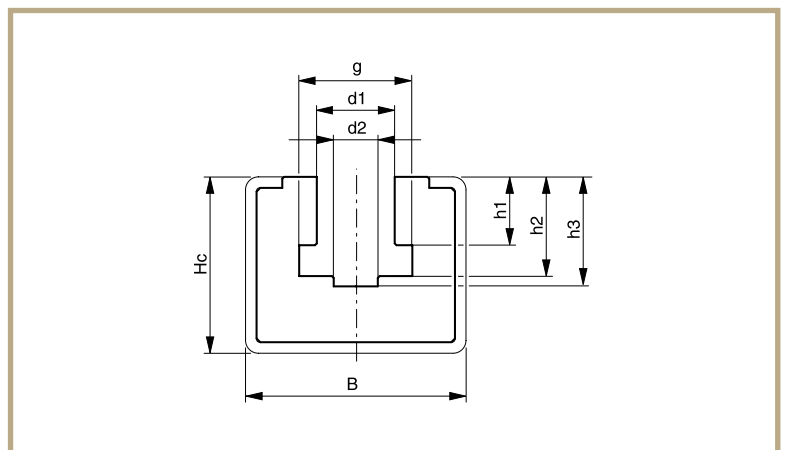

# TYPE CKG 14 H



DIN 8187 chain no.	Chain dimensions in inches	C profile type 	B	Hc	L	d1	d2	g	h1	h2	h3	Article no.
-	3/8" x 5/32"	C14H	31	25	47	6.6	4	9.4	3.6	7.0	8.0	221 410 001 351 020 014
06B-1	3/8" x 7/32"	C14H	31	25	47	6.6	4	9.4	5.5	8.9	10.0	221 410 002 351 020 014
083-1	1/2" x 3/16"	C14H	31	25	47	8.0	5	10.8	4.5	8.0	9.5	221 410 003 351 020 014
085-1	1/2" x 1/4"	C14H	31	25	47	8.0	5	11.8	6.2	9.8	11.3	221 410 020 351 020 014
g=12,8mm	1/2" x 1/4"	C14H	31	25	47	8.8	5	12.8	6.2	10.2	11.7	221 410 021 351 020 014
08B-1	1/2" x 5/16"	C14H	31	25	47	8.9	5	12.8	7.4	11.5	13.0	221 410 004 351 020 014
-	5/8" x 1/4"	C14H	31	25	47	10.6	6	15.4	6.2	10.2	11.6	221 410 022 351 020 014
10B-1	5/8" x 3/8"	C14H	31	25	47	10.6	6	15.4	9.3	13.5	14.9	221 410 005 351 020 014
12B-1	3/4" x 7/16"	C14H	31	25	47	12.4	7	17.0	11.3	15.9	17.5	221 410 006 351 020 014

Dimensions in mm · Separate ASA/JIS product catalogue available.

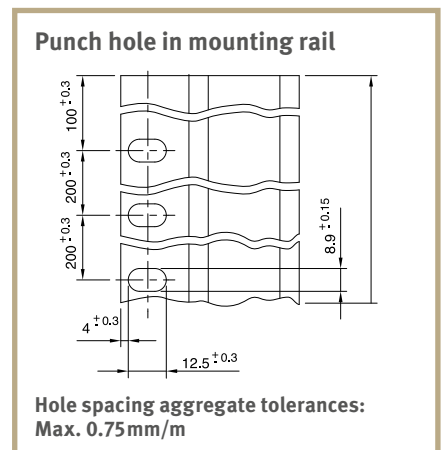
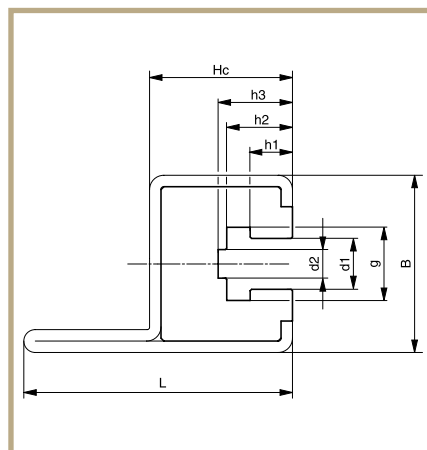

# TYPE CKG 15 V



DIN 8187 chain no.	Chain dimensions in inches	C profile type	B	Hc	L	d1	d2	g	h1	h2	h3	Article no.
-	3/8" x 5/32"	C15V	31	25	53	6.6	4	9.4	3.6	7.0	8.0	221 410 001 351 020 015
06B-1	3/8" x 7/32"	C15V	31	25	53	6.6	4	9.4	5.5	8.9	10.0	221 410 002 351 020 015
083-1	1/2" x 3/16"	C15V	31	25	53	8.0	5	10.8	4.5	8.0	9.5	221 410 003 351 020 015
085-1	1/2" x 1/4"	C15V	31	25	53	8.0	5	11.8	6.2	9.8	11.3	221 410 020 351 020 015
g=12,8mm	1/2" x 1/4"	C15V	31	25	53	8.8	5	12.8	6.2	10.2	11.7	221 410 021 351 020 015
08B-1	1/2" x 5/16"	C15V	31	25	53	8.9	5	12.8	7.4	11.5	13.0	221 410 004 351 020 015
-	5/8" x 1/4"	C15V	31	25	53	10.6	6	15.4	6.2	10.2	11.6	221 410 022 351 020 015
10B-1	5/8" x 3/8"	C15V	31	25	53	10.6	6	15.4	9.3	13.5	14.9	221 410 005 351 020 015
12B-1	3/4" x 7/16"	C15V	31	25	53	12.4	7	17.0	11.3	15.9	17.5	221 410 006 351 020 015

Dimensions in mm - Separate ASA/JIS product catalogue available.

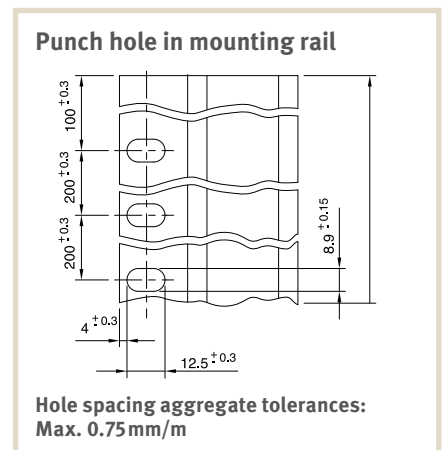
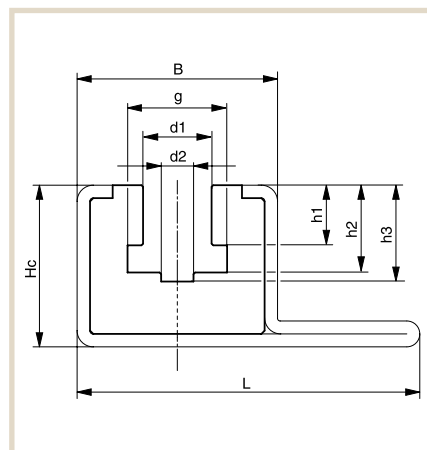

# Double-Decker Guides for Roller Chains as per DIN 8187

TYPE ETA



DIN 8187 chain no.	Chain dimensions in inches	C profile type	B	Hm	b	Bm	hm	Article no.
06B-1	3/8" x 7/32"		20	30.2	17	14.5	17	221 310 039
		C3						351 020 003
08B-1	1/2" x 5/16"		20	33.8	20	16.5	18	221 310 040
		C3						351 020 003
10B-1	5/8" x 3/8"		20	41.1	20	15.5	21	221 310 041
		C3						351 020 003
12B-1	3/4" x 7/16"		28	46.5	24	18.5	24	221 310 042
		C5						351 020 005
16B-1	1" x 17 mm		38	62.0	33	25.0	34	221 310 043
		C9						351 020 009

Dimensions in mm · Separate ASA/JIS product catalogue available.

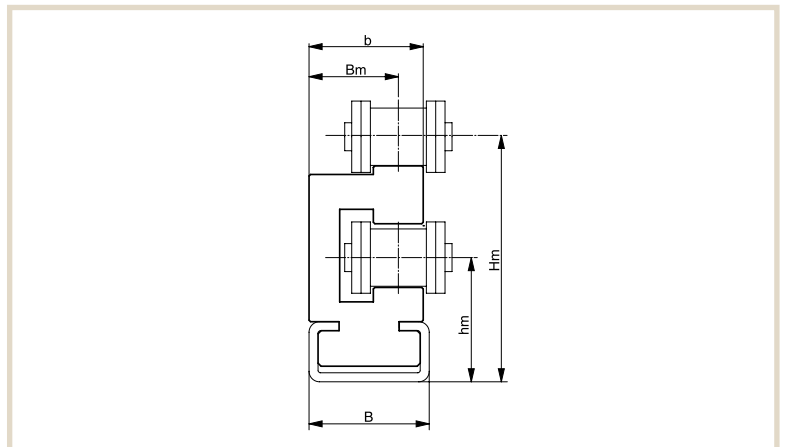

# Chain guides for round link chains as per DIN 766/764

## TYPE R



Nominal thickness d, DIN 766/764	B	H	d	h <sub>1</sub>	Article no.
6	30	15	7.0	7	231 010 001
8	38	20	9.0	9	231 010 002
10	45	25	11.5	11	231 010 003
13	55	30	15.0	15	231 010 004

Dimensions in mm

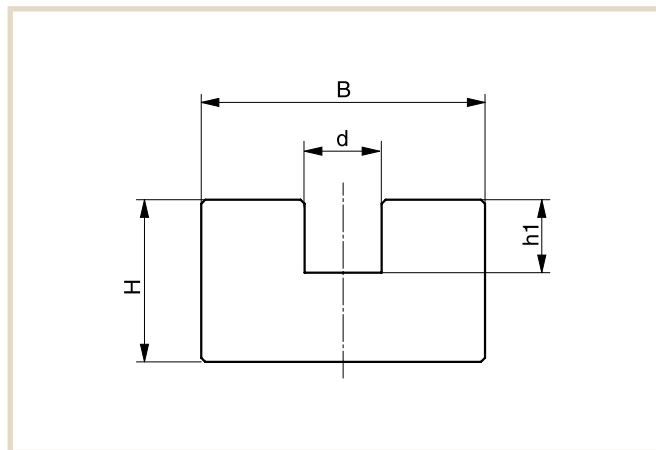

## TYPE CRU



Nominal thickness d, DIN 766/764	C profile type	B <sub>1</sub>	B <sub>2</sub>	H	H <sub>c</sub>	d	h <sub>1</sub>	Article no.
6		30		14	18	7.0	7	231 110 005
	C5		28					351 020 005
8		38		18	25	9.5	9	231 110 006
	C9		38					351 020 009
10		45		18	28	11.5	11	231 110 007
	C9		38					351 020 009
13		60		25	33	15.0	15	231 110 008
	C12		60					351 020 012

Dimensions in mm For round link chains that do not comply with DIN 766 or DIN 764 please specify dimensions.

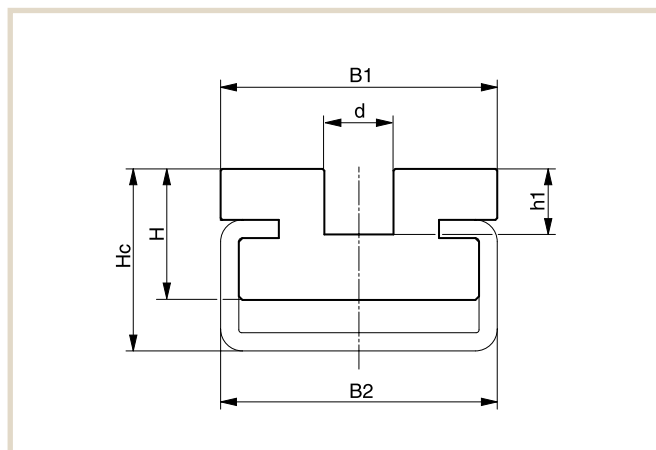



# TYPE CRG



Nominal thickness d, DIN 766/764	C profile type	B	Hc	d	h	Article no.
6	C11	45	40	7.0	8.0	231 110 009
						351 020 011
8	C11	45	40	9.5	9.5	231 110 010
						351 020 011
10	C13	65	55	11.5	14.0	231 110 011
						351 020 013
13	C13	65	55	15.0	18.0	231 110 012
						351 020 013

Dimensions in mm

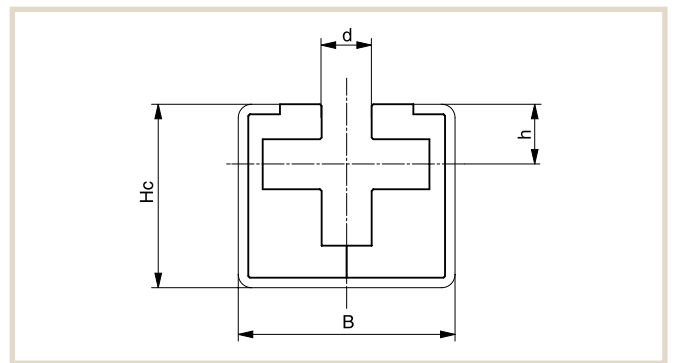

# TYPE CRO



Nominal thickness d, DIN 766/764	C profile type	B1	B2	H	Hc	d	h1	h2	Article no.
6	C3	27.0	20	32	34	7.0	17.5	10.5	231 110 001
									351 020 003
8	C5	32.0	28	39	42	9.5	20.5	12.5	231 110 002
									351 020 005
10	C9	42.5	38	53	56	11.5	25.5	16.5	231 110 003
									351 020 009
13	C12	60.0	60	67	70	15.0	33.5	20.5	231 110 004
									351 020 012

Dimensions in mm For round link chains that do not comply with DIN 766 or DIN 764 please specify dimensions.

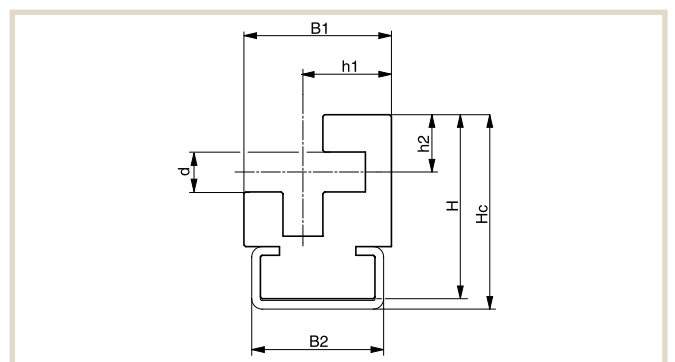

# OVERVIEW OF BELT GUIDES

## Plastic instead of metal

Belt guides made of metal cause a great deal of friction on the belts. By choosing a belt guide made of Material "S"<sup>®</sup> Black Antistatic, you considerably reduce this wear. In addition, you

save on drive energy thanks to the reduced static friction. Material "S"<sup>®</sup> Black Antistatic is suitable for use for round belts, V-belts, tooth belts and tracked tooth belts.

### For round belts

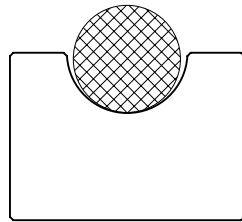

Type RR – page 95

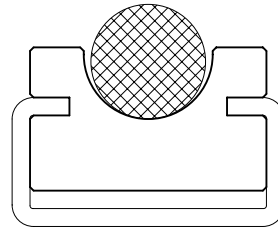

Type RRC – page 95

### For V-belts as per DIN 2215

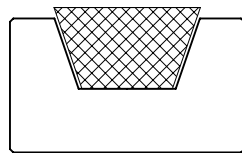

Type KR – page 96

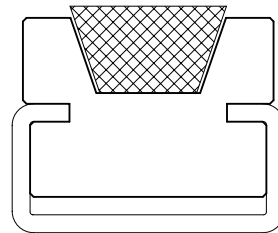

Type KRC – page 97

### For tooth belts

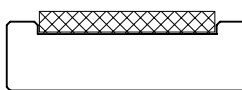

Type FR – page 98

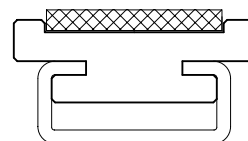

Type FRC – page 98

### For tracked tooth belts

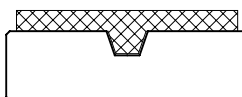

Type FK – page 99

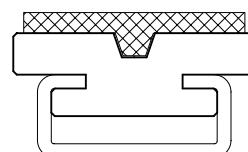

Type FKC – page 99

# Guides for Round Belts

## TYPE RR



Belt type / Ø	B	H	h	r	Article no.
5.0	20	10	3	3	231 010 027
6.3	20	10	4	4	231 010 028
8.0	20	12	5	5	231 010 029
9.5	25	15	6	6	231 010 030
12.5	28	20	8	7	231 010 031
15.0	33	25	10	9	231 010 032
18.0	38	25	12	10	231 010 033

Dimensions in mm

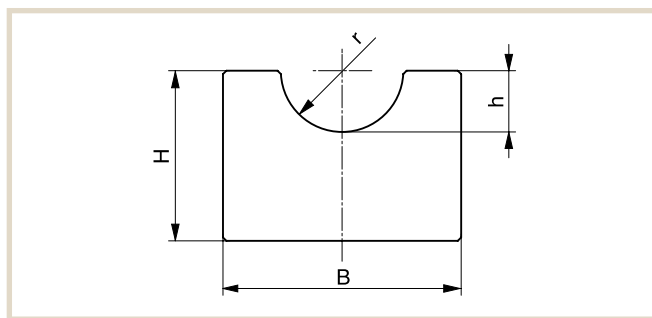

## TYPE RRC



Belt type / Ø	C profile type	B1	B2	H	Hc	h	r	Article no.
5.0	C3	20	20	10	15	3	3	231 110 035
								351 020 003
6.3	C3	20	20	15	18	4	4	231 110 036
								351 020 003
8.0	C3	20	20	15	18	5	5	231 110 037
								351 020 003
9.5	C5	25	28	15	20	6	6	231 110 038
								351 020 005
12.5	C5	28	28	15	20	8	7	231 110 039
								351 020 005
15.0	C9	33	38	20	25	10	9	231 110 040
								351 020 009
18.0	C9	38	38	20	25	12	10	231 110 041
								351 020 009

Dimensions in mm

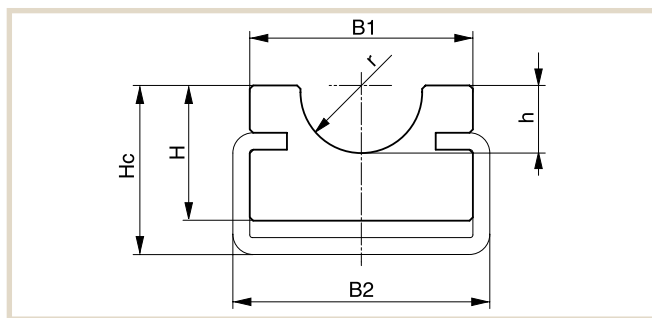

# Guides for V-belts as per DIN 2215

## TYPE KR



Belt type/b x h	B	H	b	h	Article no.
8 x 5	20	10	6.0	3.5	231 010 005
10 x 6	20	10	7.2	4.5	231 010 006
13 x 8	20	12	9.2	6.0	231 010 007
17 x 11	30	15	11.5	8.0	231 010 008
20 x 12.5	30	20	13.5	9.0	231 010 009
22 x 14	35	20	14.5	10.5	231 010 010
25 x 16	40	25	16.5	12.0	231 010 011
32 x 20	50	30	21.0	16.0	231 010 012
40 x 25	60	35	26.0	21.0	231 010 013

Dimensions in mm

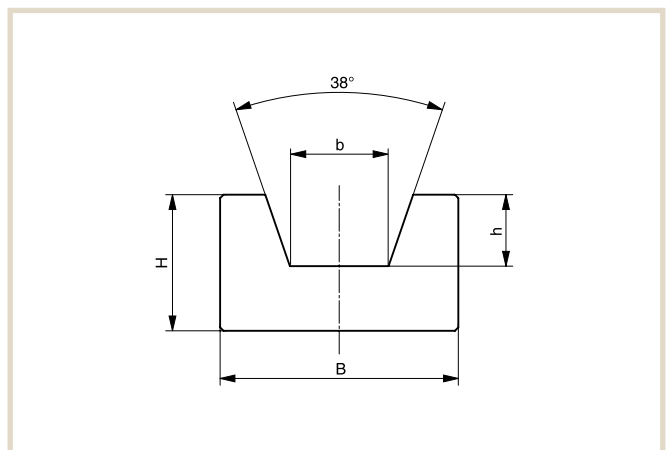

# TYPE KRC



Belt type/b x h	C profile type	B1	B2	H	Hc	b	h	Article no.
8 x 5	C3	20	20	10	15	6.0	3.5	231 110 013
								351 020 003
10 x 6	C3	20	20	15	18	7.2	4.5	231 110 014
								351 020 003
13 x 8	C5	25	28	18	22	9.2	6.0	231 110 015
								351 020 005
17 x 11	C5	30	28	18	24	11.5	8.0	231 110 016
								351 020 005
20 x 12.5	C5	30	28	18	24	13.5	9.0	231 110 017
								351 020 005
22 x 14	C9	35	38	25	30	14.5	10.5	231 110 018
								351 020 009
25 x 16	C9	40	38	25	32	16.5	12.0	231 110 019
								351 020 009
32 x 20	C12	60	60	35	40	21.0	16.0	231 110 020
								351 020 012
40 x 25	C12	60	60	35	40	26.0	21.0	231 110 021
								351 020 012

Dimensions in mm

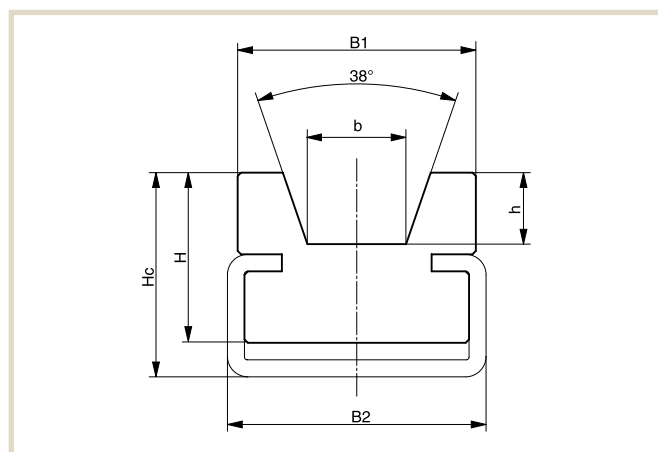



## Guides for tooth belts

### TYPE FR



Belt type	B	H	b	h	Article no.
25/T5	35	10	26	1.8	231 010 014
32/T5	45	12	33	1.8	231 010 015
25/T10	35	12	26	3.8	231 010 016
32/T10	45	12	33	3.8	231 010 017
50/T10	65	15	51	3.8	231 010 018
75/T10	90	15	76	3.8	231 010 019
100/T10	115	18	101	3.8	231 010 020

Dimensions in mm

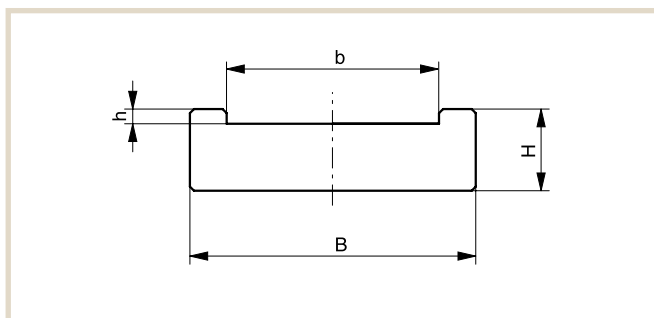

### TYPE FRC



Belt type	C profile type	B <sub>1</sub>	B <sub>2</sub>	H	H <sub>c</sub>	b	h	Article no.
25/T5		35	28	12	18	26	1.8	231 110 022
	C5							351 020 005
32/T5		45	28	12	18	33	1.8	231 110 023
	C5							351 020 005
25/T10		35	28	15	20	26	3.8	231 110 024
	C5							351 020 005
32/T10		45	28	15	20	33	3.8	231 110 025
	C5							351 020 005
50/T10		65	50	18	20	51	3.8	231 110 026
	C4							351 020 004
75/T10		90	80	18	20	76	3.8	231 110 027
	C6							351 020 006
100/T10		115	80	18	20	101	3.8	231 110 028
	C6							351 020 006

Dimensions in mm

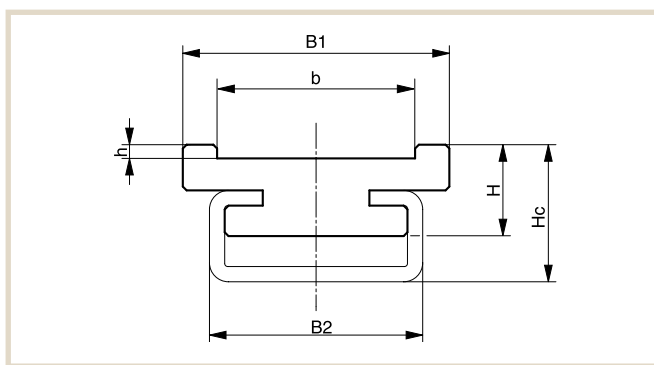

# Guides for tracked tooth belts

## TYPE FK



Belt type	B	H	b	h	Article no.
25/TK5	28	10	6.0	3.5	231 010 021
32/TK5	35	10	6.0	3.5	231 010 022
32/TK10*	35	12	9.5	4.0	231 010 023
50/TK10*	55	12	9.5	4.0	231 010 024
75/TK10	80	15	13.0	5.0	231 010 025
100/TK 10	105	15	13.0	5.0	231 010 026

Dimensions in mm

\* Standard for V-profile 10 x 6; specify any deviations!

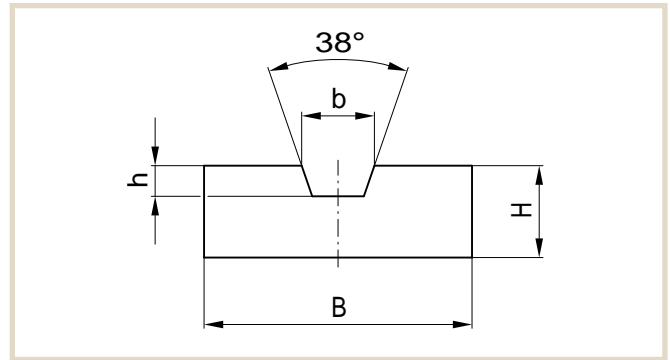

## TYPE FKC



Belt type	C profile type	B1	B2	H	Hc	b	h	Article no.
25/TK 5		28		12	18	6.0	3.5	231 110 029
	C5		28					351 020 005
32/TK 5		35		12	18	6.0	3.5	231 110 030
	C5		28					351 020 005
32/TK10*		35		12	18	9.5	4.0	231 110 031
	C5		28					351 020 005
50/TK10*		55		15	18	9.5	4.0	231 110 032
	C4		50					351 020 004
75/TK10		80		15	18	13.0	5.0	231 110 033
	C6		80					351 020 006
100/TK10		105		15	18	13.0	5.0	231 110 034
	C6		80					351 020 006

Dimensions in mm

\* Standard for V-profile 10 x 6; specify any deviations!

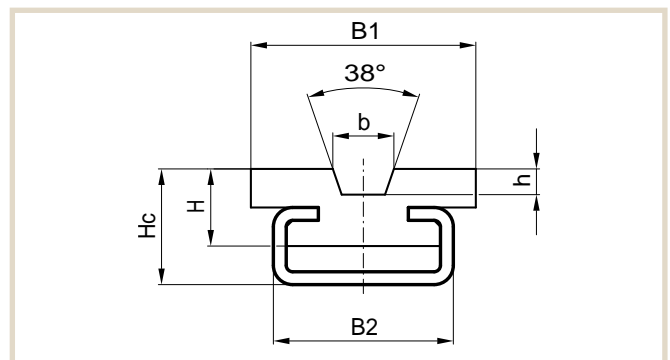

# CHAIN RACKS

Good value, flexible, and robust

Our chain racks have more than proven themselves as an economical alternative to milled racks. The system is characterized by ease of installation and simple adjustment, and is attached using an anchor plate at one end and a clamping set at the other end.

## Design

The clamping set is connected with the actual chain rack using a simplex chain connecting link. The chain is guided using a cage profile made of Material "S"<sup>®</sup>1000 green. This is clasped by a steel C profile from the outside. The steel C profiles are fixed to the base using clamps. For chain lengths of more than 2,500 mm, fastening brackets are also provided. They are integrated into the rack using duplex connection elements. This prevents the chain rack from moving in the cage profile during start-up and deceleration. Chain racks are available in chain sizes of 1/2", 5/8", 3/4" and 1".

For the full range of chain racks and prices, see [www.murtfeldt.com](http://www.murtfeldt.com).

## Advantages

- Less sensitive to tooth backlash changes. Alignment errors can thus be corrected through smaller sprocket widths
- High level of acoustic insulation
- High stability
- Cage profile can expand if temperature varies
- Simple assembly
- Economical alternative to milled racks

## Chain rack composition

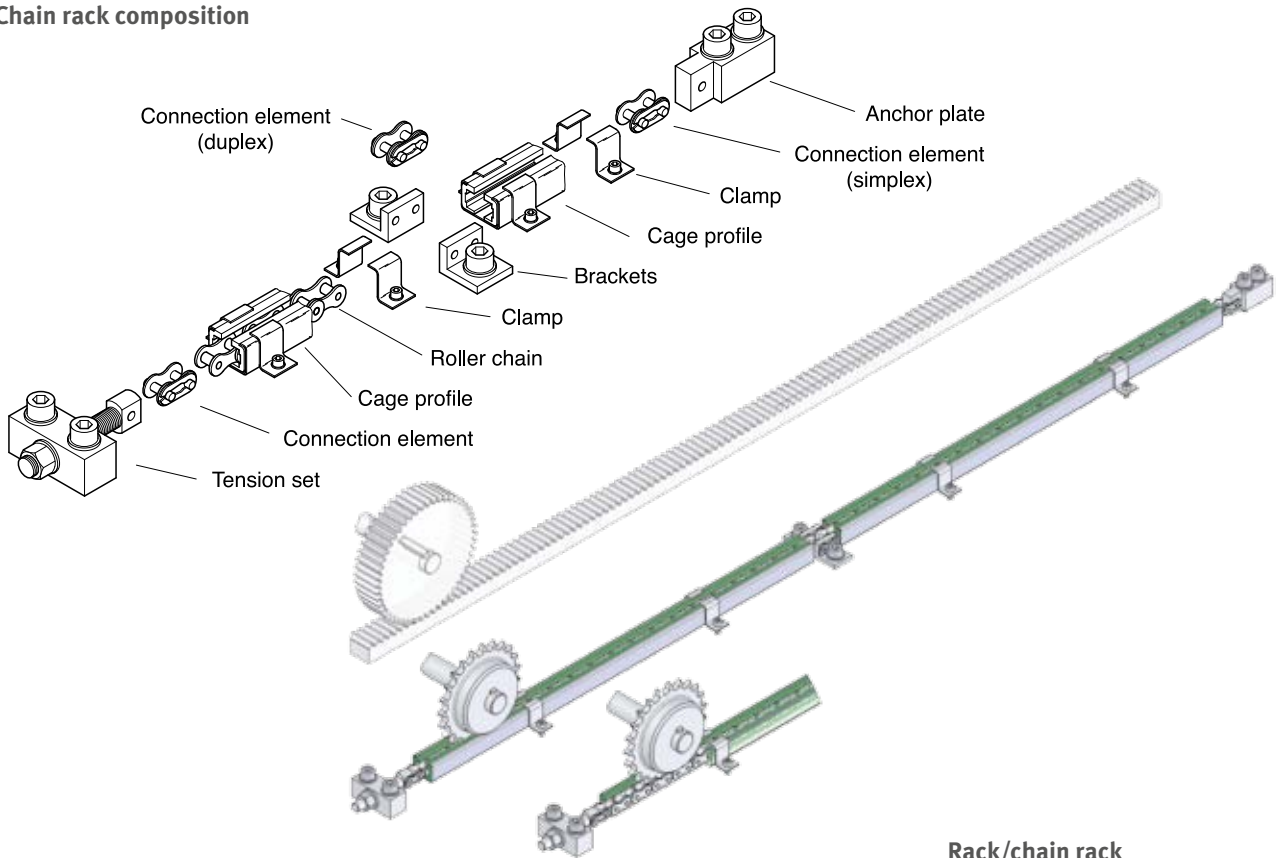

Rack/chain rack

# PROFILES FOR CONVEYING AND TRANSPORTATION

In the beverage, packaging, food, and frozen food sectors in particular, goods and products must be transported in a reliable manner that protects them from damage. We offer a wide range of products to meet this requirement.

We are happy to manufacture products on the basis of your drawings to meet the demands of your custom conveying and transport tasks. For example, we can produce carriers and work piece bearers for your conveyor belts. You can also obtain accessories such as switches and star wheels quickly and economically and in line with your requirements.

Please contact our application technology department or one of our field staff. You can also join our consultants at an online conference where you can work together on your documents in real time.

For information on the required access software for online collaboration, see [www.murtfeldt.com](http://www.murtfeldt.com).

## We offer the following products for conveying/ transportation technology:

- Sliding guides
- Rail guides
- Bands
- Clip-on profiles
- Profiles for slat band chains
- Curve guides for slat band chains

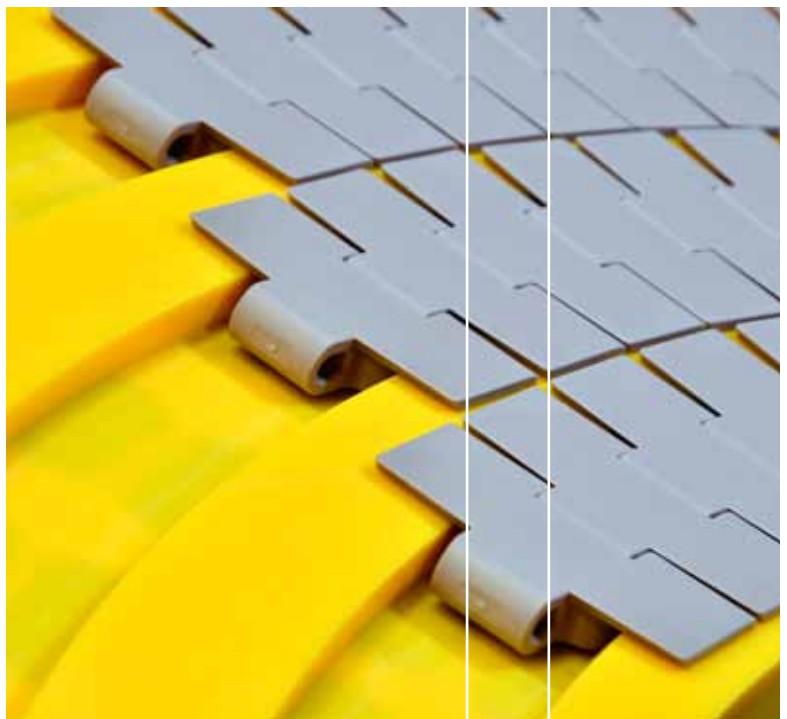
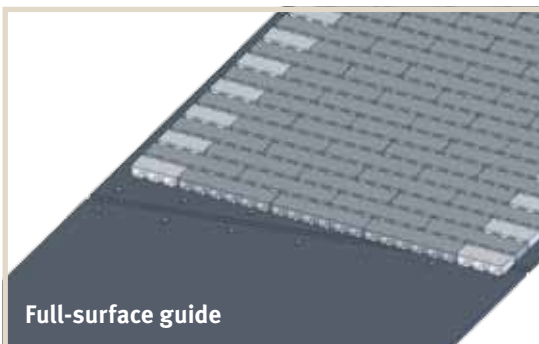
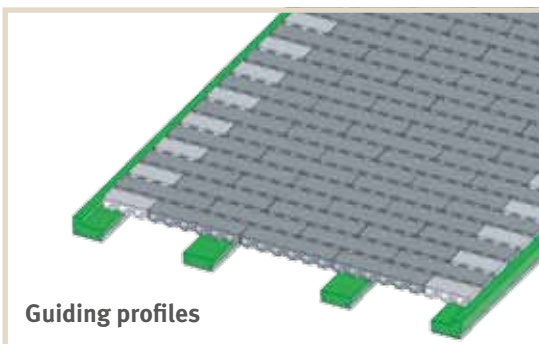

# Sliding guides

## SLIDING GUIDES TYPE CF



Type	C profile type	B1	B2	H	Hc	h	Article no.
CF		20		5	6	1.0	211 010 001
	C1		24				351 020 001
CF		20		10	11	5.8	211 010 002
	C1		24				351 020 001
CF		20		10	14	4.0	211 010 003
	C3		20				351 020 003
CF		20		14	17	7.0	211 010 004
	C3		20				351 020 003
CF		20		16	20	10.0	211 010 005
	C3		20				351 020 003
CF		28		10	15	3.0	211 010 006
	C5		28				351 020 005
CF		28		14	18	6.0	211 010 007
	C5		28				351 020 005
CF		38		12	22	4.0	211 010 008
	C9		38				351 020 009
CF		38		18	25	7.0	211 010 009
	C9		38				351 020 009
CF		60		20	30	10.0	211 010 010
	C12		60				351 020 012
CF		50		18	20	10.0	211 010 011
	C4		50				351 020 004
CF		80		18	20	10.0	211 010 012
	C6		80				351 020 006

Dimensions in mm

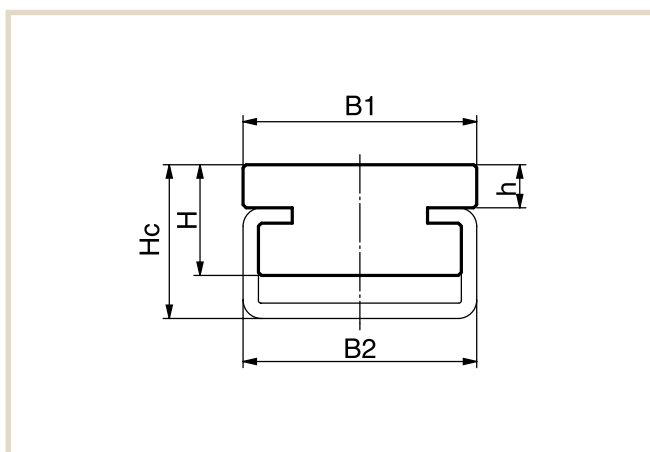



# RAIL GUIDES

## As insertion and clip profiles



Here, we present a small selection of our wide range of profiles for exemplary purposes. For our full range, see [www.murtefeldt.com](http://www.murtefeldt.com).

Rail profile	Delivery form	Delivery length in mm	Production method	Original Material "S" <sup>®</sup>	Article no.
Mushroom profile HR 2020	profile	2000	milled	green	211 210 001
	C3	2000			351 020 003
	profile	2000	milled	black antistatic	211 210 002
	C3	2000			351 020 003
	profile	2000	extruded	green	211 210 003
	C3	2000			351 020 003

Dimensions in mm Extruded profiles made of Material "S" Black are **not** antistatic.

\* For milled profiles. Tolerances as per DIN 16941 for extruded profiles.

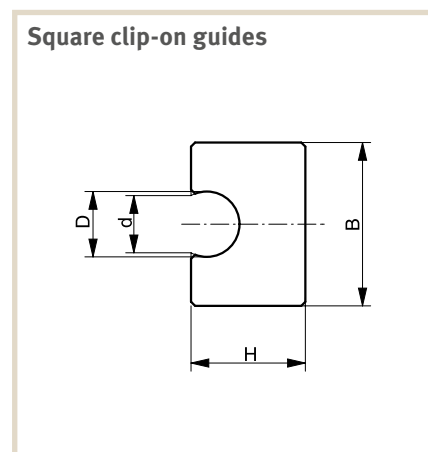
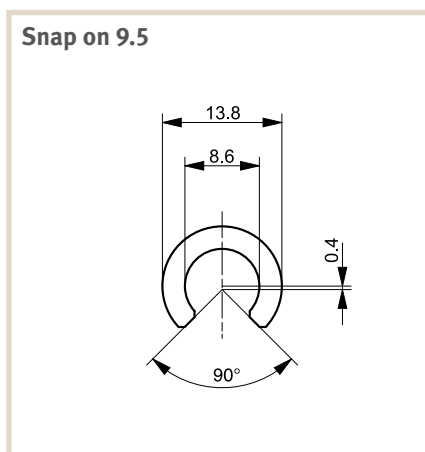
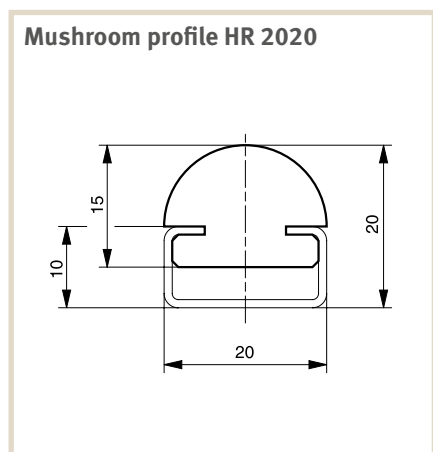



Murtfeldt plastic bands are ideally suited for transporting sensitive goods. They are available in three standard sizes. Intermediate and special dimensions are available on request.

We are happy to advise you on the correct choice of band. Please contact us.

### Design

- Either in Original Material "S"<sup>®</sup> green or Original Material "S"<sup>®</sup> Black Antistatic
- On request: Pre-treatment in the form of scraping and flaming on one side for later adhesion

### Special designs

- 6, 8 and 10mm in widths of between 10 and 60mm

### Applications

- Beverage, packaging, food, and frozen food sectors

### Special properties

- Extremely good wear resistance
- High shock and impact resistance

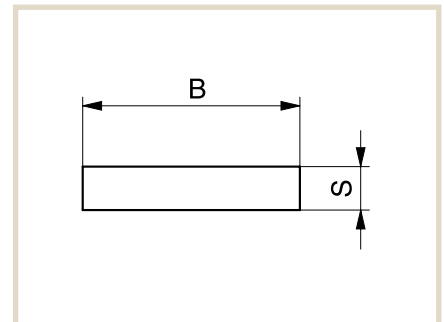

## Bands made from Original Material "S"<sup>®</sup> green

Width (B) x thickness (S)	Article no.
15 x 3	171 010 007
18 x 3	171 010 008
20 x 3	171 010 009
22 x 3	171 010 010
25 x 3	171 010 011
30 x 3	171 010 012
35 x 3	171 010 013
40 x 3	171 010 014
45 x 3	171 010 016
50 x 3	171 010 017
60 x 3	171 010 019
70 x 3	171 010 020
80 x 3	171 010 021
90 x 3	171 010 023
100 x 3	171 010 024
111 x 3	171 010 025

Width (B) x thickness (S)	Article no.
20 x 4	171 010 026
25 x 4	171 010 027
30 x 4	171 010 028
40 x 4	171 010 030
50 x 4	171 010 032

Width (B) x thickness (S)	Article no.
15 x 5	171 010 034
18 x 5	171 010 035
20 x 5	171 010 036
22 x 5	171 010 037
25 x 5	171 010 038
30 x 5	171 010 039
35 x 5	171 010 040
40 x 5	171 010 041
45 x 5	171 010 042
50 x 5	171 010 043
60 x 5	171 010 044

\* Tolerances: Thickness ± 0.1 / width ± 0.5. Roll length on request

# SLIP-ON PROFILES



Here is a small selection of our extensive range of profiles.  
View our complete range at [www.murtefeldt.com](http://www.murtefeldt.com).

**Plastic C profile for flat steel,  
30 × 3 milled/extruded**

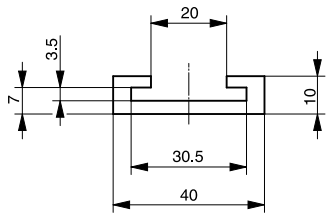

**Plastic C profile for flat steel, 40 × 8 milled**

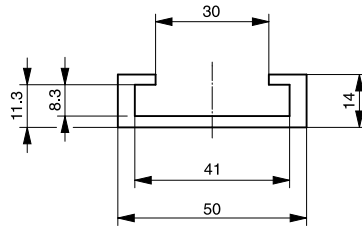

**Plastic C profile for flat steel, 40 × 8 extruded**

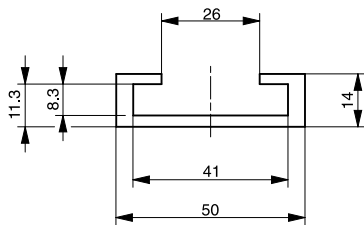

**Plastic C profile for flat steel, 40 × 10 milled**

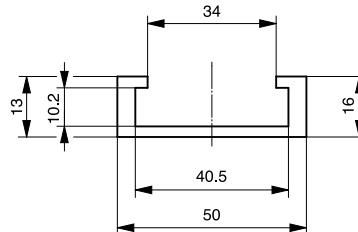

**Plastic C profile for flat steel, 40 × 10 extruded**

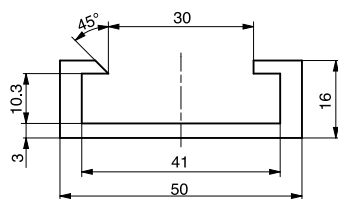

**Plastic C profile for flat steel, 50 × 6 milled**

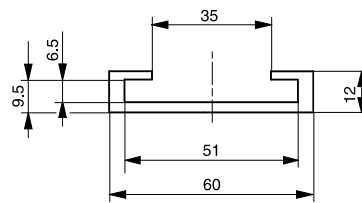

**Plastic C profile for flat steel, 50 × 6 extruded**

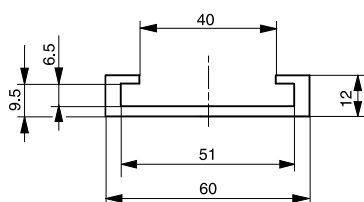

**Plastic L profile for flat steel, 40 × 8 milled**

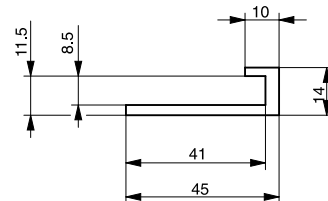

\* For milled profiles. Tolerances as per DIN 16941 for extruded profiles.

# PROFILES FOR SLAT BAND CHAINS



**L profile 20 x 5**

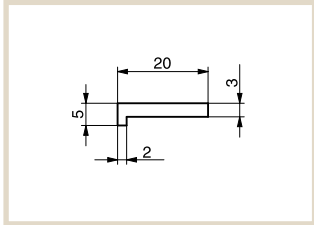

**L profile 20 x 5.5**

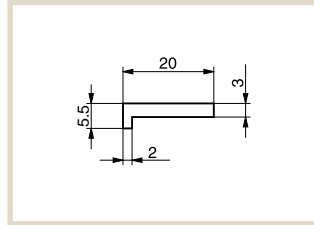

**L profile 20 x 6**

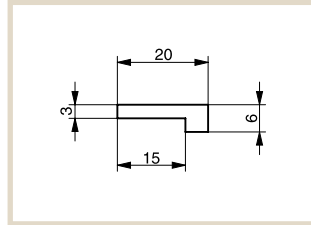

**L profile 25 x 6**

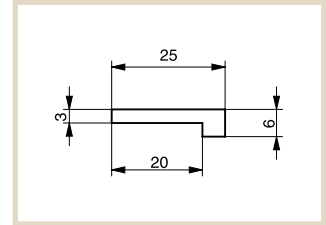

Profile	Roll length (in m)	Production method	Original Material™S™®	Article no.
L profile 20 x 5	35	milled	green	211 310 034
L profile 20 x 5.5	50	extruded	green	211 310 044
L profile 20 x 6	45	milled	green	211 310 035
L profile 25 x 6	45	milled	green	211 310 036

**Slide profile type U 45 x 6**

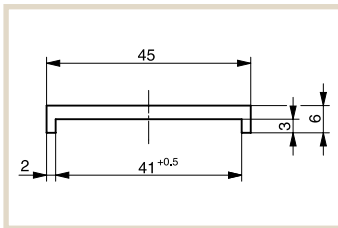

**Centre profile 40 x 6**

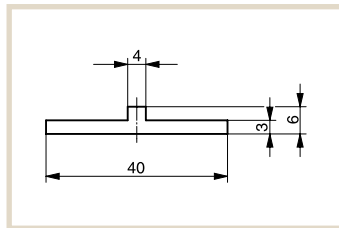

**Centre profile 40 x 5.5**

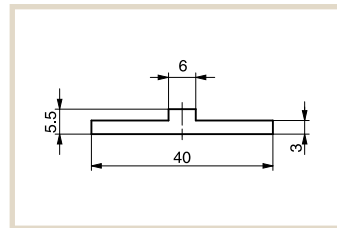

Profile	Roll length (in m)	Production method	Original Material™S™®	Article no.
Slide profile type U 45 x 6	35	milled	green	211 310 037
Centre profile 40 x 6	35	milled	green	211 310 033
Centre profile 40 x 6	50	extruded	green	211 310 042
Centre profile 40 x 5.5	50	extruded	green	211 310 001

**Bridge centre profile 40 x 7.5**

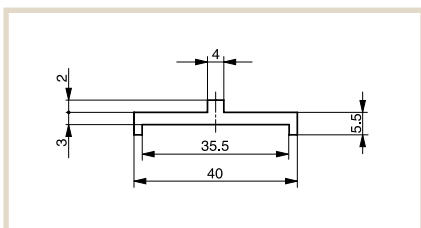

**Bridge centre profile 45 x 15**

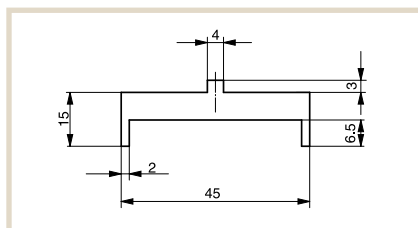

Profil	Roll length (in m)	Production method	Original Material™S™®	Article no.
Bridge centre profile 40 x 7.5	50	extruded	green	211 310 043
Bridge centre profile 45 x 15	6	extruded	green	211 310 002

Dimensions in mm Extruded profiles made of Material "S" black are **not** antistatic.

\* For milled profiles. Tolerances as per DIN 16941 for extruded profiles.

# PROFILES FOR SLAT BAND CHAINS



**Flat clamping profile 21 x 9**

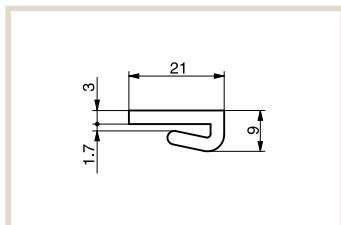

**Flat clamping profile 26 x 11.8**

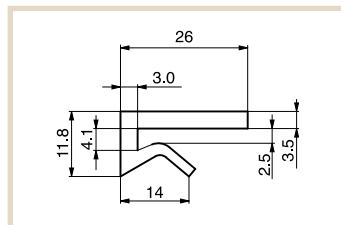

Profile	Roll length (in m)	Production method	Original Material™S™®	Article no.
Flat clamping profile 21 x 9	50	extruded	green	211 310 004
Flat clamping profile 26 x 11.8	50	extruded	natural	211 310 039

**L clamping profile 21 x 11**

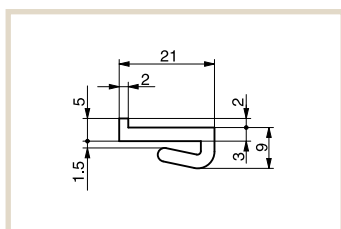

**L clamping profile 22 x 11**

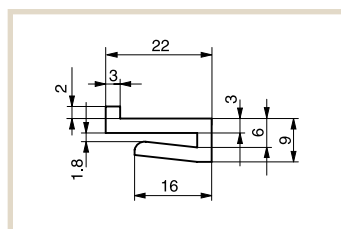

**L clamping profile 26 x 14.8**

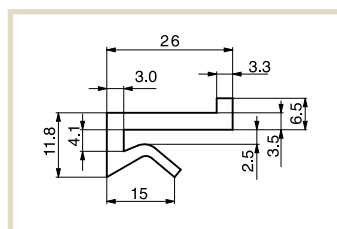

Band profile	Roll length (in m)	Production method	Original Material™S™®	Article no.
L clamping profile 21 x 11	50	extruded	green	211 310 005
L clamping profile 22 x 11	65	extruded	green	211 310 041
L clamping profile 26 x 14.8	30	extruded	natural	211 310 040

**Clamping U profile 6.3 x 8.7**

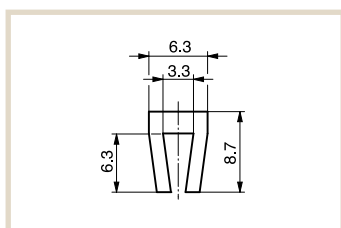

**T clip-on profile 40 x 20.5**

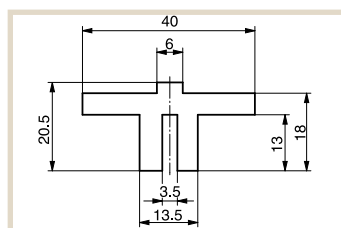

**Z profile 20 x 8**

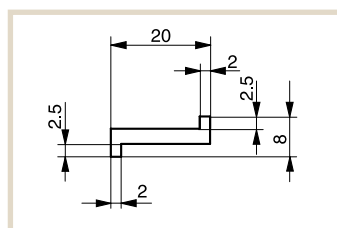

Profile	Roll length (in m)	Production method	Original Material™S™®	Article no.
Clamping U profile 6.3 x 8.7	50	extruded	natural	211 310 007
T clip-on profile 40 x 20.5	2	milled	green	211 310 030
Z profile 20 x 8	35	milled	green	211 310 031
	50	extruded	green	211 310 038



## CURVE GUIDES FOR SLAT BAND CHAINS

### Made-to-measure or off the shelf

Steel slat-band chains are preferable for the transport of bottles and components, like coupling components, bearings or gears. To significantly reduce abrasion as well as background noise when handling these components, Murtfeldt recommends the use of plastic curve guides. These guides are ideal for the transport of sensitive products, avoiding breakage of glass bottles, preventing crushing with dairy products and avoiding scratching with PET bottles.

These curve guides form part of Murtfeldt's standard range. However, Murtfeldt's capacity to produce curve guides tailored to the customers' specific requirements is even greater.

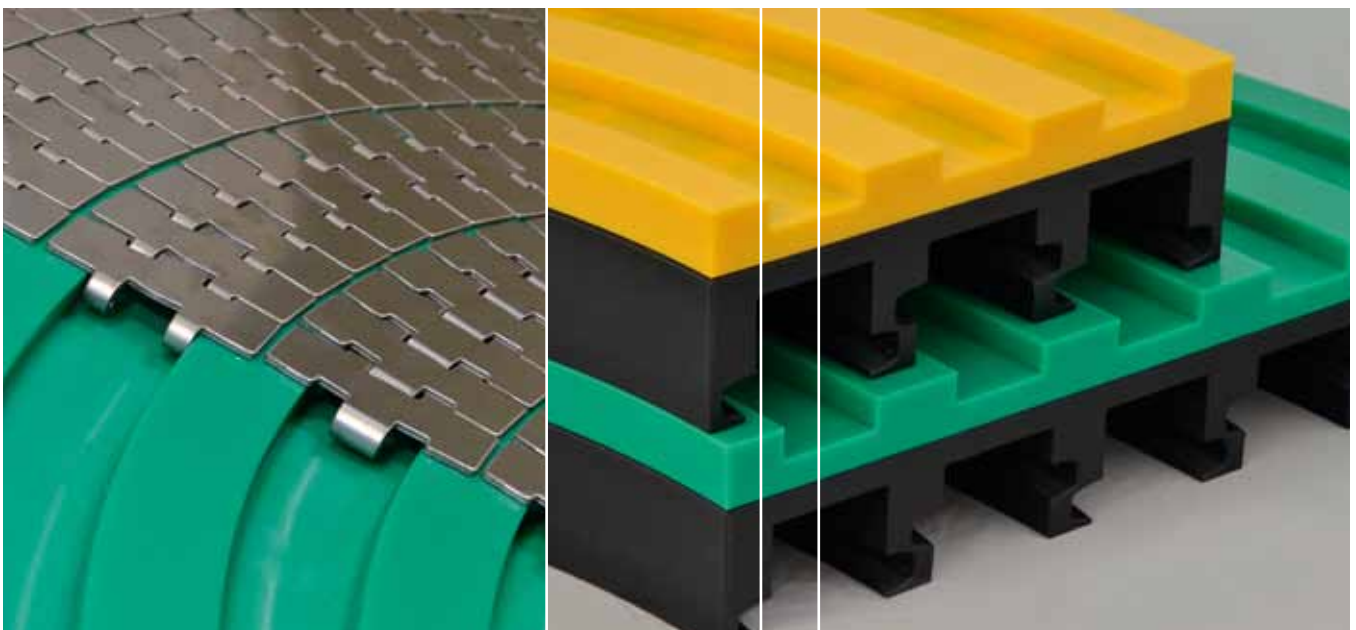

# CURVE GUIDES FOR SLAT BAND CHAINS

**Shown with TAB guide, with and without straight ends**

Our production plant is state of the art and professionally set up for the production of individual TAB, dovetail and magnetic curve guides. We can make your detailed requirements a reality. Download the TAB design questionnaire below on our website, as well as the questionnaires for dovetail and magnetic curve guides.

**Further questionnaires are available to download at [www.murtfeldt.com/services/design-questionnaires/](http://www.murtfeldt.com/services/design-questionnaires/)**

Please use the questionnaire to provide us with the necessary technical data or get in touch with our application engineers who will be pleased to help you immediately with producing the necessary drawings.

YOUR CONTACT DETAILS	
Name, first name	
Company	
Postal code, city	
Street	
Phone	
Fax	
E-Mail	

TEAM APPLICATION TECHNOLOGY
We are happy to provide free, non-binding advice on selecting the suitable design and material of your curve guide.
Please send the fill-out form to: <b>technik@murtfeldt.de</b>
or print it out and send it by fax to: <b>Fax 0049 (0) 231 20609-518</b>

DIMENSIONS IN MM			
H	R1		Segment angle
B	R2		Length (with straight ends)
b1	R3		a
b2	R4		
h1	R5		
h2	R6		

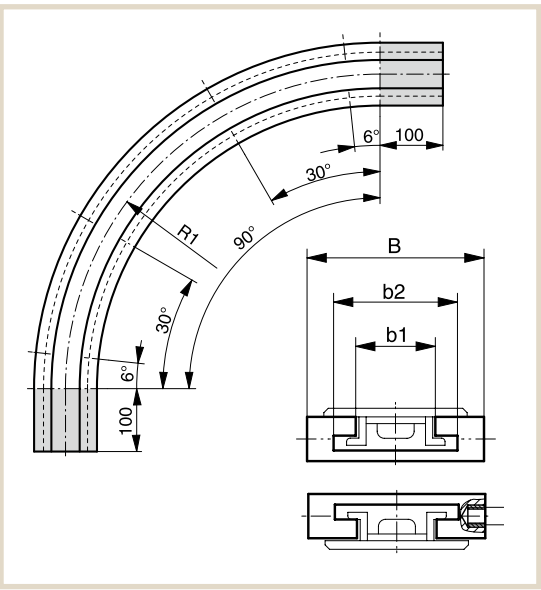

BAUART					
Countersunk hole	YES	NO	Quantity		/
Thread insert	YES	NO	Quantity		/
Material for curve guide					
Type of chain					

REMARKS

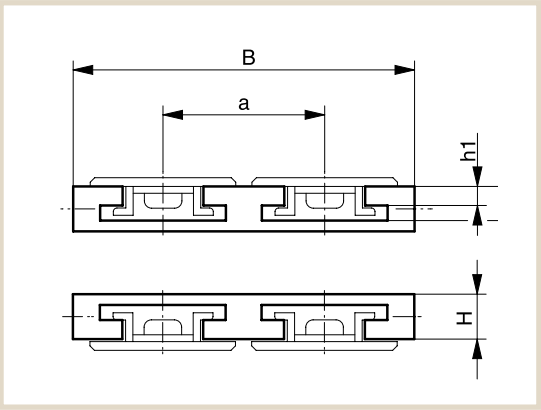

# GUIDES FOR MODULAR BELTS

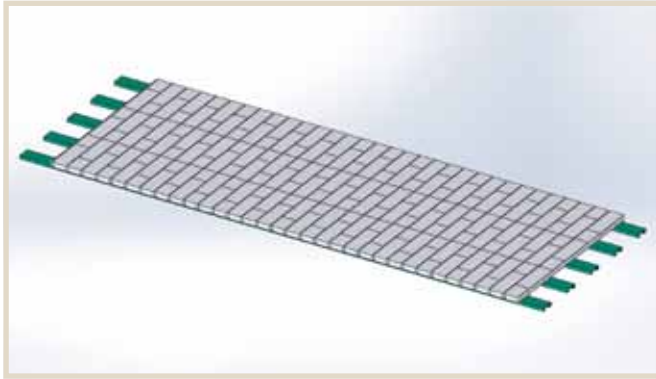

Slip-on profiles

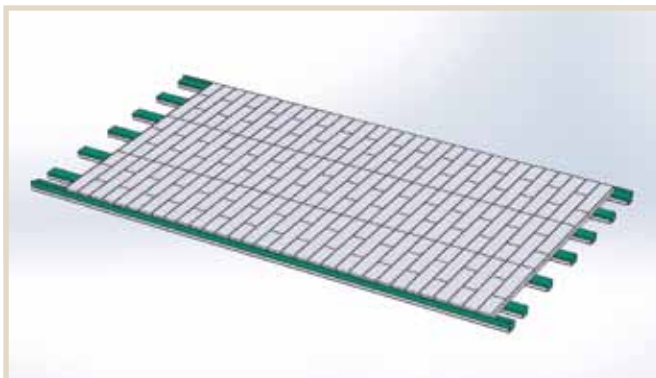

CF profiles

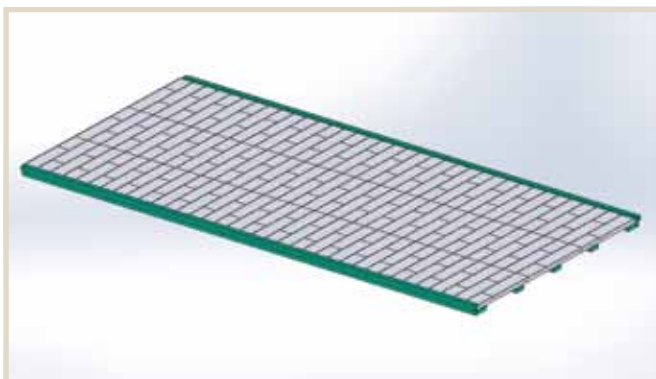

Flat profiles with hold-down clips

Conveyor belts are highly modular and can even be integrated into the most complex systems. Murtfeldt Plastics produces guides for modular belts, manufactured from highly wear-resistant, low-friction plastics like Original Material "S"<sup>®</sup> green, "S"<sup>®</sup> plus+ LF or "S"<sup>®</sup> plus+ ESD. These guides are used as solid sliding bases, and also as CF profiles, slip-on profiles or sliding guides with tongue and groove in a straight or an arrow-shaped arrangement. You will find our solutions in almost all sectors, in the packaging industry, as well as in filling plants or in the automotive sector.

## At a glance: Guides for modular chains

- Flat profiles
- Profiles with hold-down clips
- Slip-on profiles (C for flat steel)
- CF profiles
- Flat profiles with tongue and groove
- V-shaped flat profiles
- Solid guides (based on a drawing)

## Materials

- Original Material "S"<sup>®</sup> plus+ LF
- Original Material "S"<sup>®</sup> plus+ LF ESD
- Original Material "S"<sup>®</sup> plus+ ESD
- Original Material "S"<sup>®</sup> plus+ Bright ESD
- Original Material "S"<sup>®</sup> black antistatic

## Benefits

- Low sliding friction
- Excellent wear resistance
- No static charge depending on the design

# GUIDES FOR MODULAR BELTS

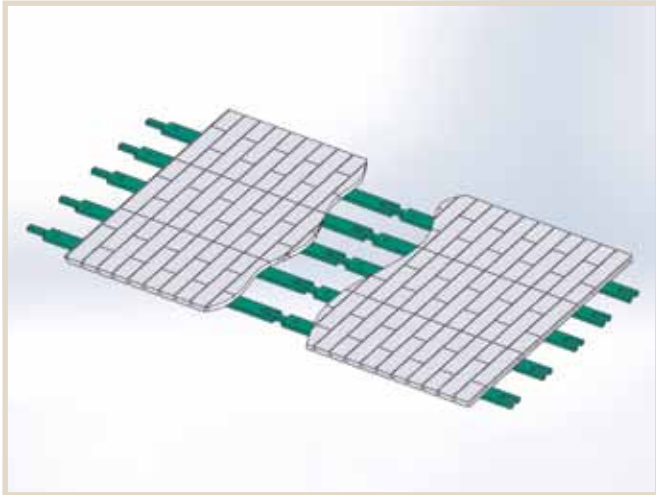

Flat profiles with tongue and groove

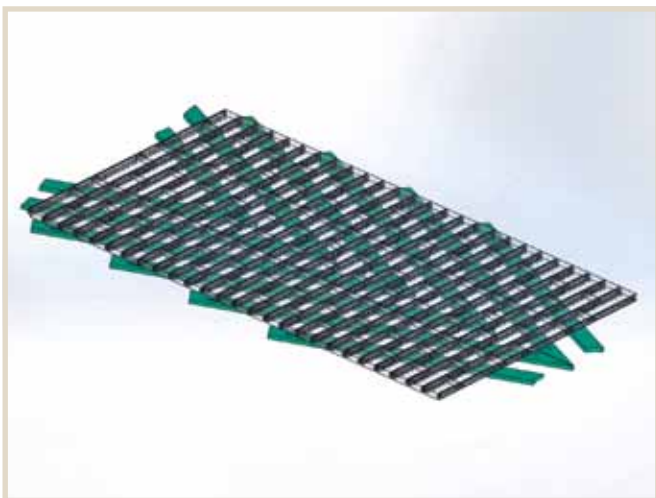
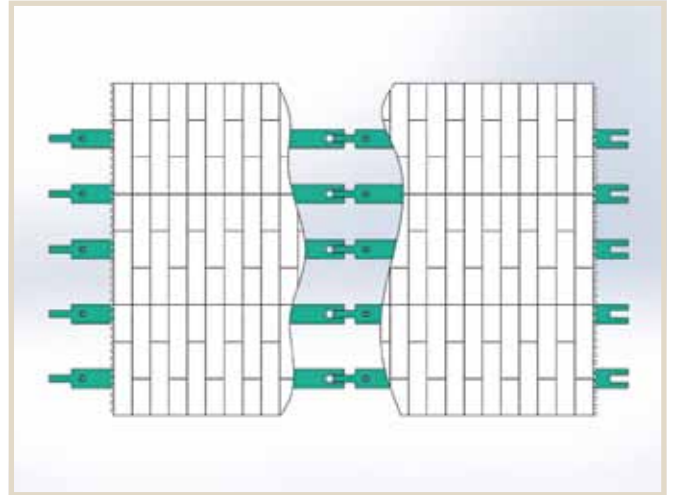

Arrow shape

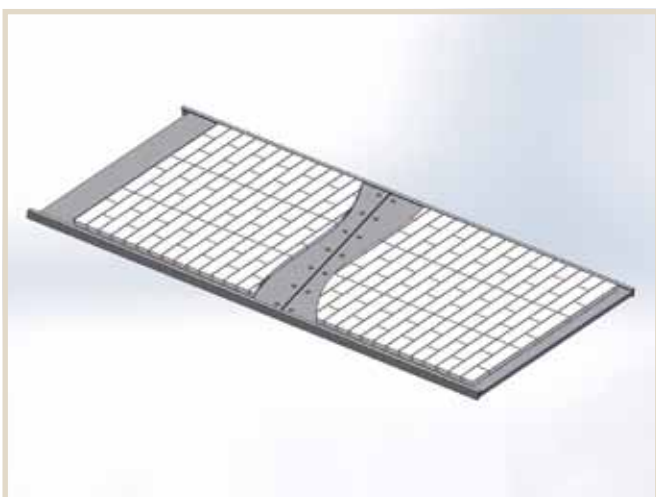
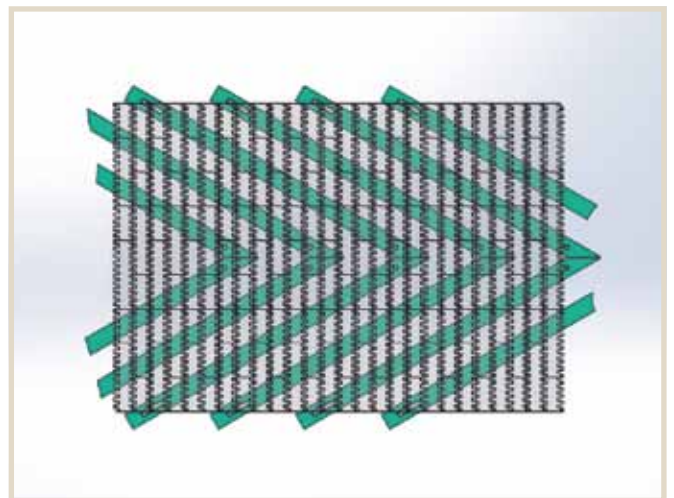

Solid sliding base

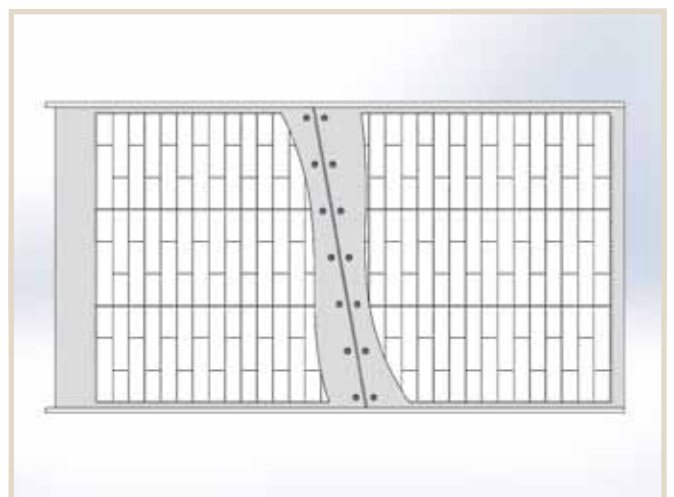







## TENSIONING SYSTEMS

## TENSIONING SYSTEMS – TABLE OF CONTENTS

Table of Contents	114
Introduction	115
Function, Principles, Handling	116
Optical Control Displays	117
Spann-Box® Overview	118 – 119
Signs and Symbols	119
The Correct Choice of Chain Tensioner	120
Selection Table for Tensioning Systems	121 – 122
Graphical Depiction of Installation Examples	123
Mounting Brackets for Spann-Box® Systems	124 – 125
Inductive Switches	126
Chain Tensioners for Roller Chains as per DIN 8187	127 – 139
Mini-Tensioner, Spann-Boy®TS, Spann-Box® size 0, Spann-Box® size 30, Spann-Box® size 1, Spann-Box® size 2	
Automatic Belt Tensioners	140 – 145
Spann-Boy®TS, Spann-Box® size 0, Spann-Box® size 1, Spann-Box® size 1 Type SR-L, Spann-Box® size 1 Type SR-S	
Special Tensioners	146 – 147

# TENSIONING SYSTEMS

## For chains and belts

Chains and belts are important wearing parts in many plants and machines. Since they are constantly moving, the stresses to which they are subjected are particularly high. Belts require pretensioning – chain links elongate and run increasingly less smoothly.

Murtfeldt tensioning systems keep chains and belts reliably tensioned, thus increasing their lifetime. They are tried-and-tested following decades of use around the world. Our experience with these systems enables us to provide you with optimum advice and to always offer the best possible solution for your needs.

### Wide range – extensive inventory

Thanks to our variety of different tensioning systems, we are able to quickly and accurately meet practically any requirements. If you require an individual solution, our free-of-charge, non-binding consulting services are sure to help.

**One more thing: We supply all tensioning systems with a declaration of installation in line with the Machinery Directive EC 2006/42/EC.**

### Advantages of our tensioning systems

- Smooth chain movement
- Reduction in wear on chain links and drive sprockets
- Reduction in working noise
- Automatic adjustment
- Compensation for chain and belt elongation
- Use as chain and belt monitors
- Direction change for chain and belt drives
- Small installation size
- Simple assembly
- Quick and safe recognition of need to adjust system thanks to optical control display



# FUNCTION, PRINCIPLES, HANDLING

Our tensioning systems are free-running and resilient. As a result, they do not function as rigid deflectors when stressed. This avoids excessive contact pressure. Our systems aim to keep the overall force on the slack strand – resulting from the weight of the chain and the centrifugal force – under control. The ideal installation position is right behind the drive sprocket in order to keep the length of the slack strand that needs to be tensioned as short as possible.

### Tried-and-tested quality

The stable design of the steel housing makes our tensioning systems resistant to high mechanical loads. Our housings and tensioning systems are galvanized, which provides protection against corrosion. A plastic lacquer makes the surface impact and scratch resistant. In addition, we offer a stainless steel range for particularly high corrosion resistance requirements. All slide profiles are made of Original Material "S"®.

### Installation

Special holding mechanisms initially hold back the spring action. When these retainers are released following the installation, the tensioning pressure is released in a targeted manner.

### Tension force regulation

For all Murtfeldt tensioning systems, you can choose either light or heavy tensioning pressure. Depending on the type, the tensioners have one, two, or three springs. You decide how many springs you want to use. This enables the optimum application of pressure onto a chain or belt running on the profile.

### Use at extreme temperatures

If you choose the correct material, you can also use our tensioning systems in otherwise problematic temperature ranges:

Normal steel springs: -10 to +170°C

Stainless steel springs: -40 to +200°C

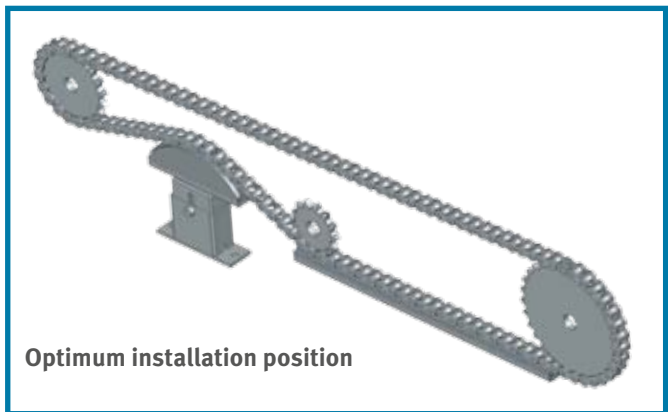

Optimum installation position

Employees from our application technology department are constantly available to make sure that we are able to provide the best product to meet your requirements.

The weight on the return side of the chain that is to be tensioned should not be greater than the force of a spring already 50% released.

The red dot on the Spann-Box® and/or the red plastic clips visible at the bottom of the Spann-Box® signify "heavy tension force".



## OPTICAL CONTROL DISPLAYS

Murtfeldt Spann-Box® systems generally have a coloured scale. This enables you to determine the tensioning state of the chain at a glance. The display is as easy to understand as possible:

---

### ■ Green

The chain tensioner is working in the “green range”. The tensioning force is providing an ideal, smooth running movement.

---

### ■ Yellow

The tensioning force is not ideal but is still sufficient.

---

### ■ Red

The chain tensioner needs to be adjusted. The tensioning force on the chain is too low for a smooth and reliable running movement.

---

The chain has to be replaced if it is not possible to sufficiently adjust the chain tensioner using any of the available adjustment options.





# OVERVIEW OF SPANN-BOX® TYPES

## Chain tensioners

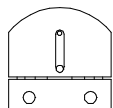

Mini-tensioner  
page 127

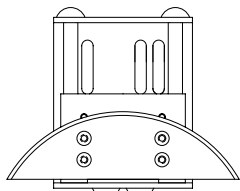

Spann-Boy® TS with arc  
segment profile – page 128

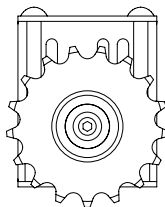

Spann-Boy® TS  
with sprocket – page 129

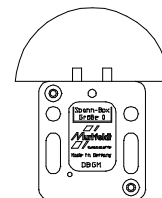

Spann-Box® size 0  
page 130

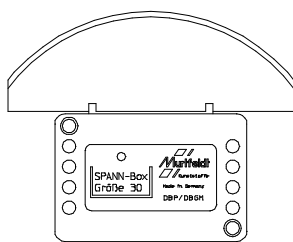

Spann-Box® size 30  
page 131

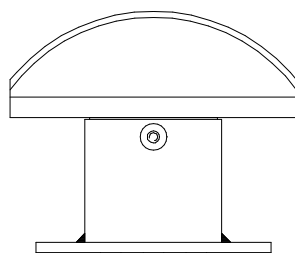

Spann-Box® size 1 with arc  
segment profile – page 132

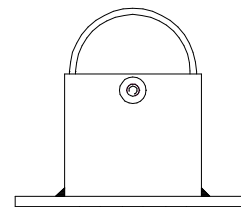

Spann-Box® size 1 with  
semi-circular profile – page 133

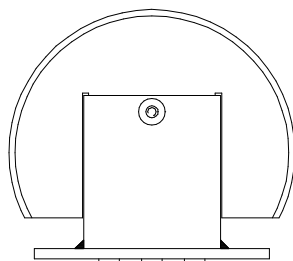

Spann-Box® size 1 with return  
profile – page 134

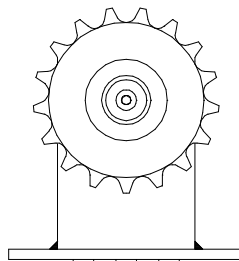

Spann-Box® size 1 with sprocket  
Type K-L – page 135

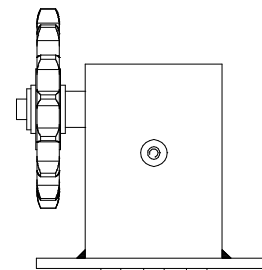

Spann-Box® size 1 with  
sprocket Type K-S – page 135

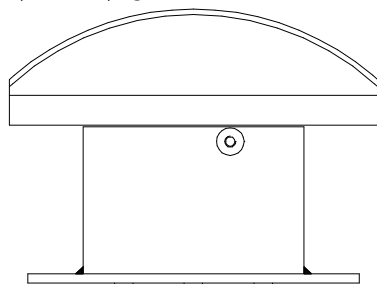

Spann-Box® size 2 with arc segment profile – page 136

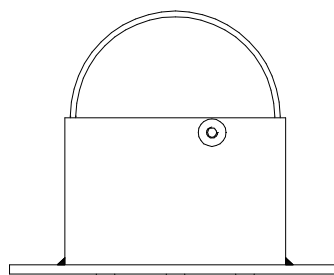

Spann-Box® size 2 with semi-circular profile – page 137

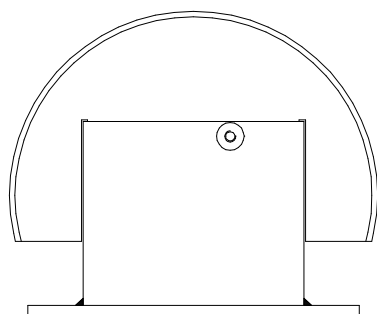

Spann-Box® size 2 with return profile – page 138

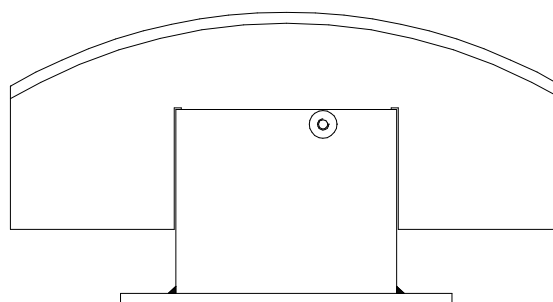

Spann-Box® size 2 with block profile – page 139

## THE CORRECT CHOICE OF CHAIN TENSIONER

### Belt tensioners

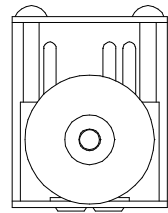

Spann-Boy® TS  
tensioning roller – page 141

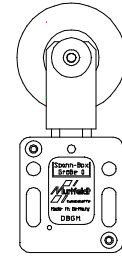

Spann-Box® size 0  
page 142

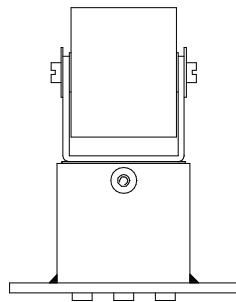

Spann-Box® size 1 belt tensioner with  
tensioning roller at top – page 143

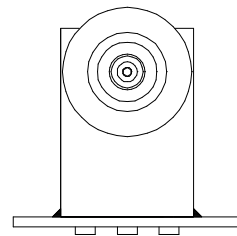

Spann-Box® size 1 with  
tensioning roller type SR-L – page 144

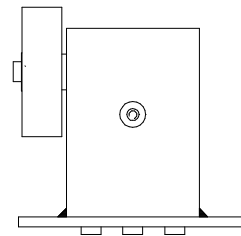

Spann-Box® size 1 with  
tensioning roller type SR-S – page 145

Smooth running is a decisive factor for the long lifetime of a chain. We therefore recommend the use of a chain tensioner with a slide profile. Advantage: Protects the chain links and provides a quieter, safer movement.

We are happy to provide detailed advice if you inform us of the required criteria. Our Web site at [www.murtefeldt.com](http://www.murtefeldt.com) contains a design questionnaire that you can use to enter all required data.

### IMPORTANT CRITERIA WHEN SELECTING THE BEST CHAIN TENSIONER FOR YOUR NEEDS

- Axis-centre distances of sprockets
- Chain design
- Constant/changing running direction
- Chain speed
- Chain lubrication
- Operating time and intensity
- Risk of contamination
- Environmental temperature
- Chemical influences

## SIGNS AND SYMBOLS

### Features and properties of tensioning systems



One pre-tensioned compression spring,  
tension distance specification in mm



Two pre-tensioned compression springs,  
tension distance specification in mm



Three pre-tensioned compression springs,  
tension distance specification in mm



Further adjustment possible: Adjustment range in mm  
once original tension distance has been used (value  
for size 1 and size 2 if using mounting bracket)



Plastic housing



Steel housing (also stainless steel)



Track profile for all large chains



U profile for chains up to specified overall  
width in mm

# SELECTION TABLE FOR CHAIN TENSIONERS

1) It is possible to use several types of SPANN-BOX® alongside each other with duplex or triplex chains.  
 2) Slide profile or return pulley with U-profile.

Simplex chain

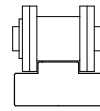



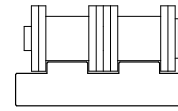



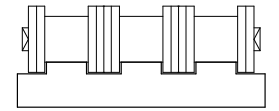



































































































Duplex chain



Triplex chain



Chain	Pitch	inch	MINI-TENSIONER	SPANN-BOY®TS with arc segment profile	SPANN-BOY®TS with sprocket	SPANN-BOX® size 0	SPANN-BOX® size 30	SPANN-BOX® size 1	SPANN-BOX® size 2	MINI-TENSIONER	SPANN-BOY®TS with arc segment profile	SPANN-BOX® size 0	SPANN-BOX® size 30	SPANN-BOX® size 1	SPANN-BOX® size 2	SPANN-BOY®TS	SPANN-BOX® size 0	SPANN-BOX® size 30	SPANN-BOX® size 1	SPANN-BOX® size 2
DIN ISO	mm																			
Unspecified chains with a width of up to 15 mm <sup>2)</sup>			 2)	 2)	 2)	 2)					 2)	 2)	 2)							
06B	9,525	3/8		 2)	 2)	 2)	 2)	 2)	 2)				 2)	 2)	 2)				 2)	 2)
08B	12,7	1/2						 2)	 2)					 2)	 2)				 2)	 2)
10B	15,875	5/8						 2)	 2)					 2)	 2)				 2)	 2)
12B	19,05	3/4						 2)	 2)					 2)	 2)				 2)	 2)
16B	25,4	1						 2)	 2)					 2)	 2)				 2)	
20B	31,75	1 1/4						 2)	 2)					 2)	 2)				 2)	
24B	38,1	1 1/2						 2)	 2)					 2)	 2)				 2)	
28B	44,45	1 3/4						 2)	 2)					 2)	 2)				 2)	
32B	50,8	2						 2)	 2)					 2)	 2)				 2)	
40B	63,5	2 1/2						 2)	 2)					 2)	 2)				 2)	
48B	76,2	3						 2)	 2)					 2)	 2)				 2)	

## EXPLANATION OF SYMBOLS

Profiles symbols for selection tables



### Arc segment profile

- Slide profile shape with optimum mechanical properties
- Simultaneous contact with several rollers
- Optimum chain protection



### Return profile

- 180° change of direction
- The 180° change of direction permits the dual use of longer tension distances.



### Block profile

- Suitable for particularly heavy chains and high mass forces
- Slide profile and tension core made from a single piece
- No screw connections
- Excellent stability
- 300 mm slide profile ensures support for many rollers with chains with large chain pitches



### Semi-circular profile

- For 90° deflection
- Contact with only very few chain rollers
- Recommended where space is at a premium



### Roller/sprocket

- For small changes of direction
- For high chain speeds (>1 m/s)

# GRAPHICAL DEPICTION OF INSTALLATION EXAMPLES

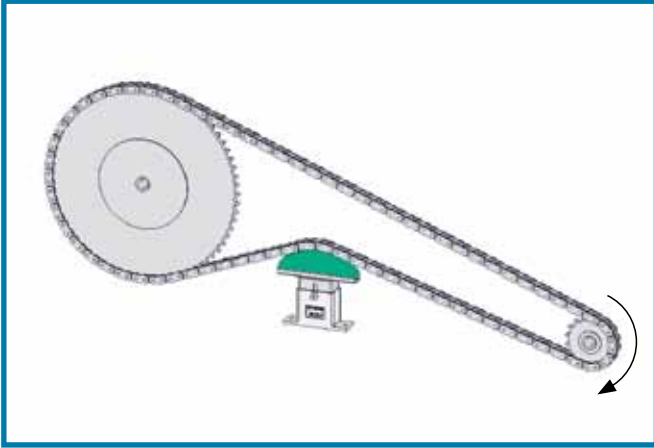

Popular but non-optimal arrangement, tension distance not used efficiently

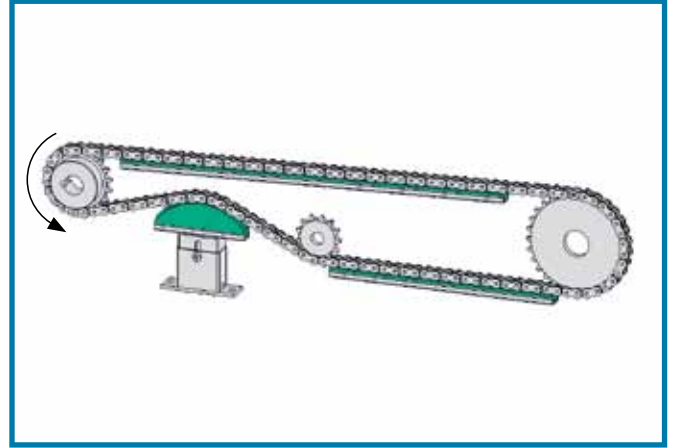

Optimum, extremely efficient chain support/tensioning

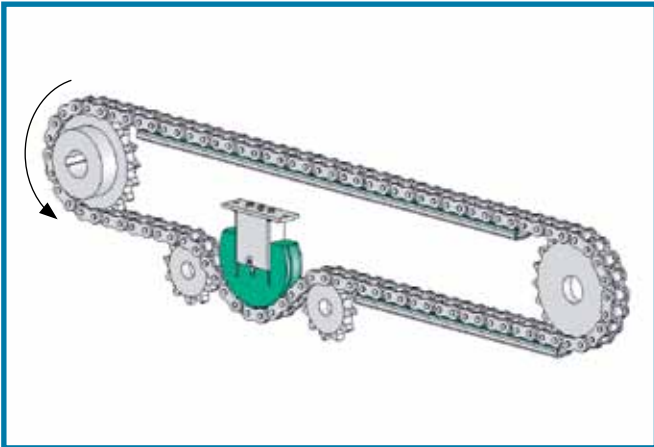

180° return profile. This arrangement allows a particularly long chain length to be accommodated.

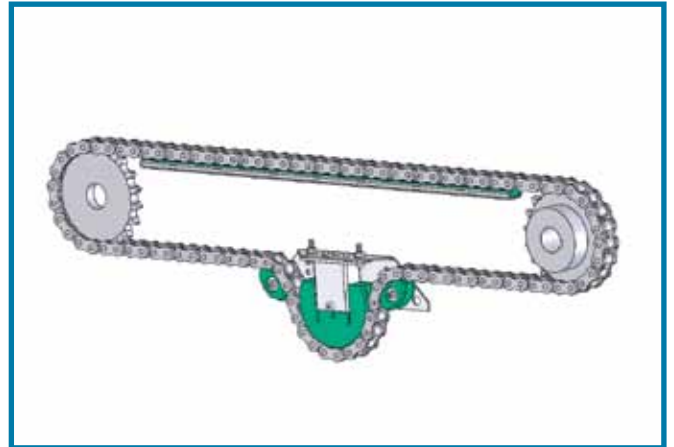

Omega tensioning station – ready-to-install system

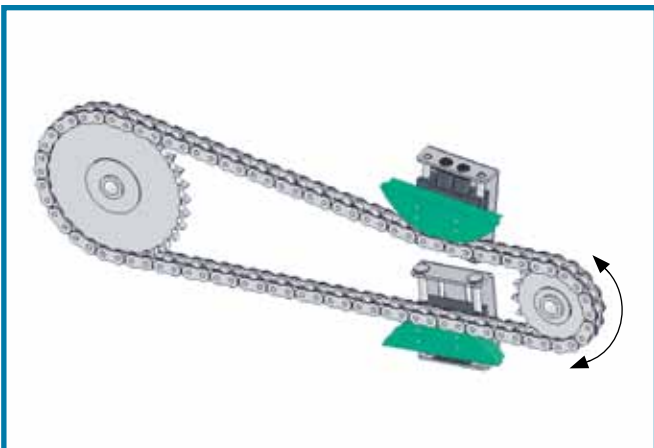

If the running direction changes, we recommend using two Spann-Box® units near to the drive.

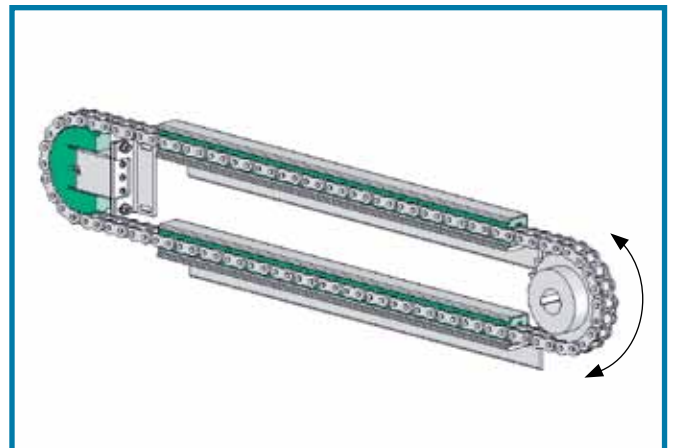

Return/tensioning station

# MOUNTING BRACKETS FOR SPANN-BOX® SYSTEMS

## The ideal assembly aid

We offer various mounting brackets to make assembly more easy. They provide additional modification/adjustment flexibility. Elongated mounting holes allow easy adjustment if the normal tension distance has already been used up. Alignment errors can be corrected by side movement.

We are happy to provide detailed assembly instructions for all our systems. Simply contact us or see our website at [www.murtfeldt.com](http://www.murtfeldt.com).

Corresponding size	Adjustment range	Material	Article no.
1	67 mm	St 37 powder-coated	281 090 001
2	75 mm	St 37 powder-coated	281 090 002
1	67 mm	1.4301 (stainless steel)	281 090 029
2	75 mm	1.4301 (stainless steel)	281 090 030
0	-	1.4301 (stainless steel) incl. screws	281 090 087
30	-	1.4301 (stainless steel) incl. screws	281 090 088
TS	-	1.4301 (stainless steel)	281 090 091
1 (alternative fixing)	87 mm	1.4301 (stainless steel)	281 090 092

### Size 1 and 2

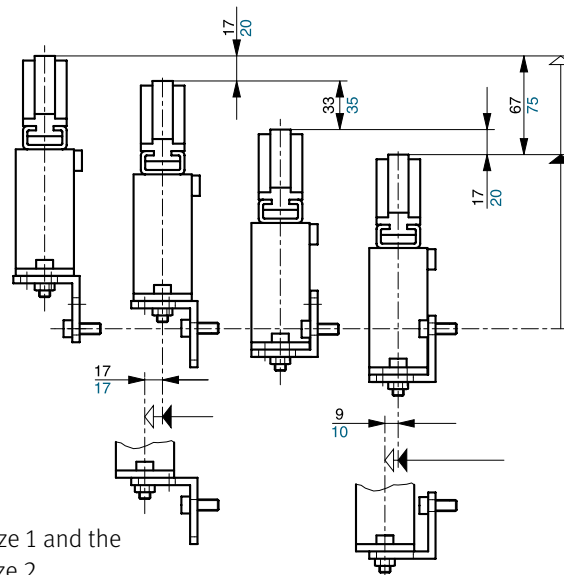

The top numbers are for size 1 and the bottom numbers are for size 2.

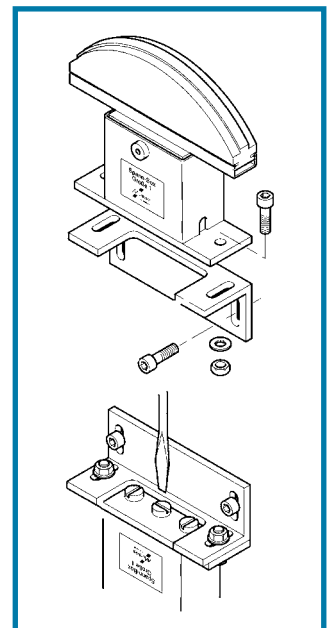



### Spann-Boy® TS

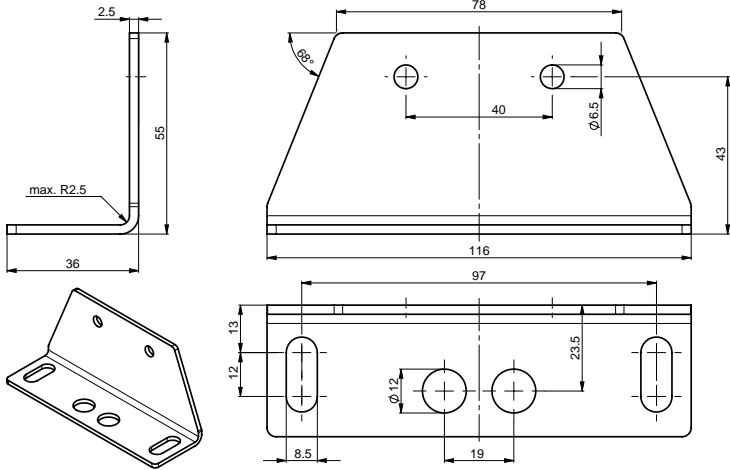

### Spann-Box® size 0

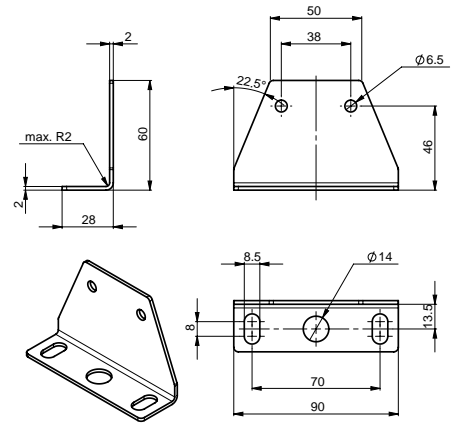

### Spann-Box® size 1 (standard)

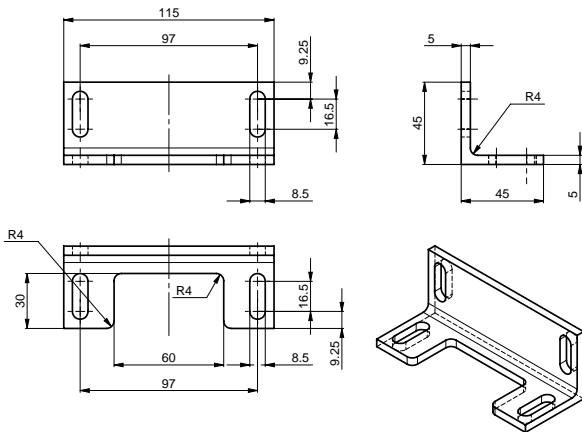

### Spann-Box® size 1- alternative fixing

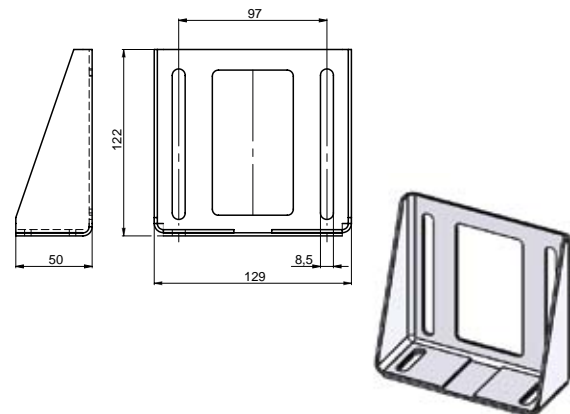

### Spann-Box® size 2

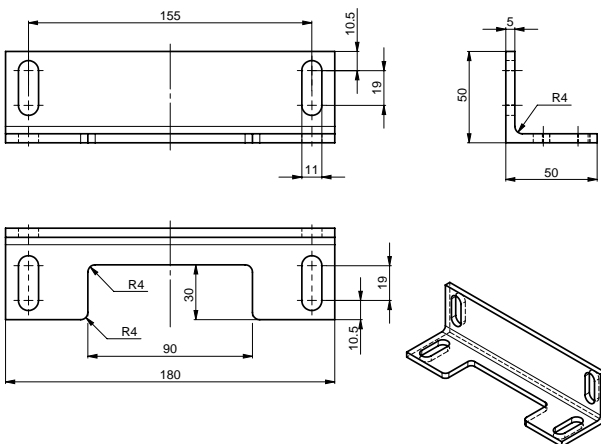

### Spann-Box® size 30

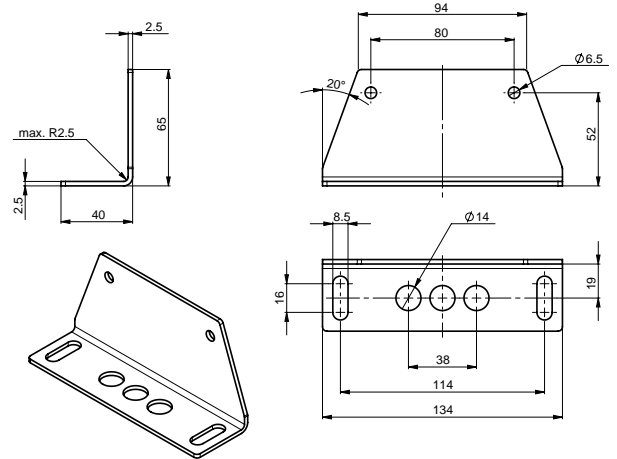

## CHAIN AND BELT MONITORS

If a chain has excessive elongation or a break, critical damage can occur. Our chain and belt monitors track the production process and trigger the automatic shutdown of the machine if malfunctions occur. For this purpose, a mechanical limit switch or contact-free inductive switch is integrated into your chain or belt tensioner.

### Both individual and reliable

Switch design requirements can vary greatly. Please contact us for more information. We will design the best solution for your requirements.

### Inductive switches for Spann-Box®

Alternatively, a contact-free inductive switch can be used. This makes sense if there is a risk of explosion or contamination. Concerns about wear might also result in the use of an inductive switch. Inductive switches can be used for Spann-Box® size 1 and 2. Special models and designs in stainless steel are available on request.



# CHAIN TENSIONERS FOR ROLLER CHAINS PER DIN 8187

## MINI-TENSIONER

The smallest automatic chain tensioner in our range, the mini-tensioner is targeted for use with smaller chains with a chain pitch of up to 1/2.

Tension force	Light	Heavy
	2 springs	19 – 13 N
Tension distance	16 mm	16 mm

## MINI-TENSIONER

with arc segment profile



### Tensioning pressure

- Choice of light or heavy spring force

### Chain guide

- Track profile for 06B-1, 08B-1 and duplex chains

### Attachment

- Screws on bracket base

### Axis-centre distance

- Max. 200mm recommended

DIN 8187 chain no.	Light tension force Article no.	Heavy tension force Article no.
<06B-1 (U-Profil)	281 050 001	281 050 002
06B-1	281 050 003	281 050 004
08B-1	281 050 009	281 050 010
10B-1	-	281 050 011
05B-2	281 050 005	281 050 006
06B-2	281 050 007	281 050 008

Special and stainless steel designs on request

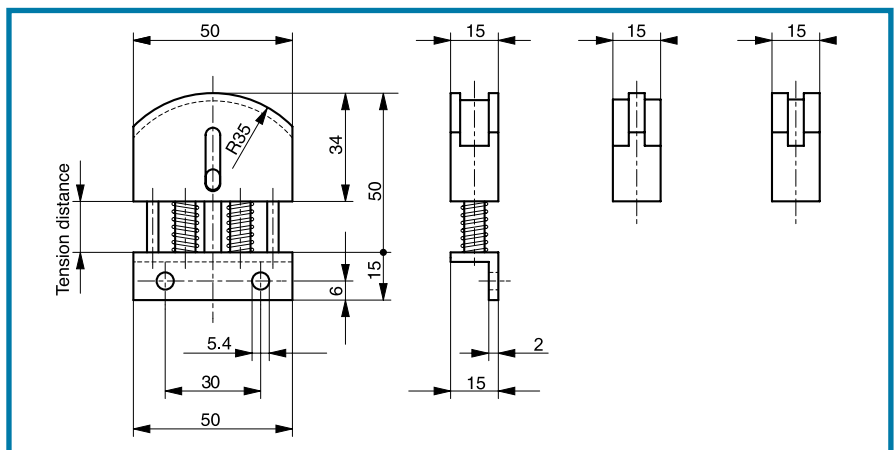
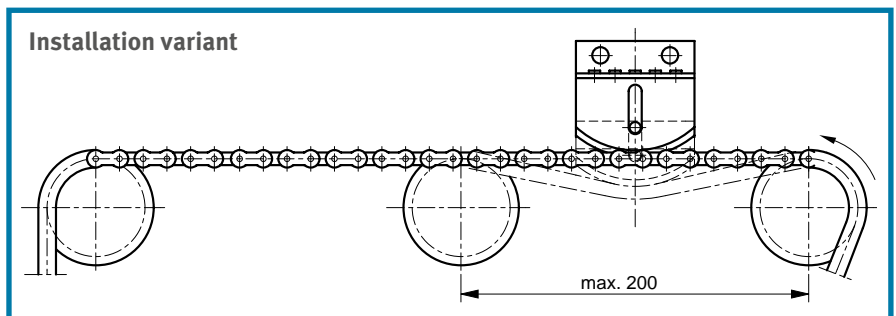

# SPANN-BOY® TS

## Three tension pressure settings

If the space beneath the chain is not large enough for a traditional tensioning system, Spann-Boy® TS can be used. They are installed near to the chain and thus require considerably less space.

### Design

Our Spann-Boy® TS models are made from robust steel. The focus is on achieving a long lifetime and reliability. There are two different variants: With an arc segment profile or with a sprocket. Spann-Boy® TS has two pre-tensioned

springs. They can be released separately and provide three different tension pressure settings. The bore holes in the housing make assembly easier and provide more scope for adjustment once the original tension distance has been used up.

		Light	Heavy
Tension force Spann-Boy® TS	1 released spring	58 – 32 N	132 – 60 N
	2 released springs	190 – 96 N (extra heavy)	
	Tension distance	40 mm	40 mm

# SPANN-BOY® TS

## with arc segment profile



### Applications

- For applications with restricted free space beneath the chain. 40mm are sufficient.

### Tensioning pressure

- Spann-Boy® TS has one light and one heavy pressure spring that can be released together or separately depending on the required tension pressure.

### Attachment

- Installed next to the chain
- Bore holes in the housing (for matching fastening brackets refer to pages 124 – 125)

DIN 8187 chain no.	B	a	Article no. Standard design	Article no. Stainless steel
≤06B-1 (U-Profile)	20	10,0	281 060 001	282 060 002
08B-1	20	16,5	281 060 003	282 060 004
10B-1	20	15,6	281 060 005	282 060 006
12B-1	20	14,8	281 060 007	282 060 008
06B-2	20	7,5	281 060 009	282 060 010
08B-2	32	15,2	281 060 011	282 060 012
10B-2	32	11,3	281 060 013	282 060 014
05B-3	20	7,4	281 060 015	282 060 016
06B-3	32	9,4	281 060 017	282 060 018

Special designs on request

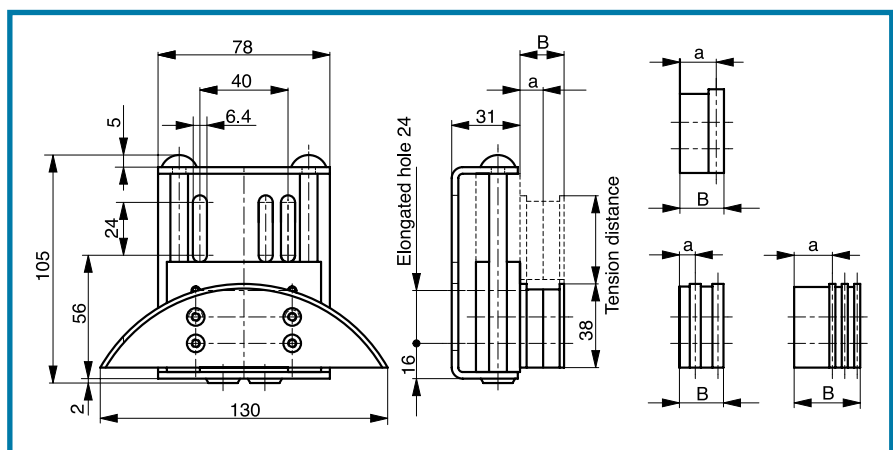

# SPANN-BOY® TS

with sprocket

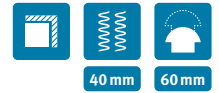

## Applications

- For applications with restricted free space beneath the chain
- High chain speeds (>1m/s)
- Small return radii

## Tensioning pressure

- Spann-Boy® TS has one light and one heavy pressure spring that can be released together or separately depending on the required tension pressure.

## Attachment

- Installed next to the chain
- Bore holes in the housing (for matching fastening brackets refer to pages 124 – 125)

DIN 8187 chain no.	Number of teeth	Article no. Standard design
06B-1	20	281 260 002
06B-1	21	281 260 003
06B-1	23	281 260 004
08B-1	16	281 260 005
08B-1	17	281 260 006
08B-1	18	281 260 007
10B-1	14	281 260 008
10B-1	15	281 260 009
10B-1	16	281 260 010
10B-1	17	281 260 011
12B-1	13	281 260 012
12B-1	15	281 260 013
12B-1	16	281 260 014
12B-1	17	281 260 015

Special and stainless steel designs on request

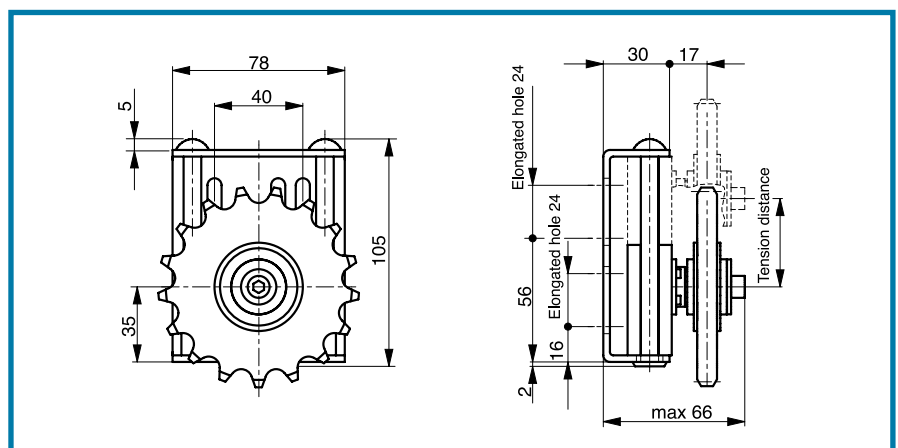

# SPANN-BOX® SIZE 0

The Spann-Box® size 0 is the smallest in our range. It is used where installation spaces are very restricted. The plastic housing means there is no risk of corrosion.

		Light	Heavy
Tension force	1 spring	58 – 32 N	132 – 60 N
	Tension distance	40 mm	40 mm

## SPANN-BOX® SIZE 0 with semi-circular profile

### Stainless steel screws and springs



#### Applications

- Restricted installation space
- Environments with a risk of corrosion
- Chain drives with a pitch of up to 3/4"

#### Tensioning pressure

- Choice of light or heavy spring force
- Lock pin in base of housing

DIN 8187 chain no.	Light tension force Article no.	Heavy tension force Article no.
≤06B-1 (U-Profile)	281 000 001	281 000 002
08B-1	281 000 003	281 000 004
10B-1	281 000 003	281 000 004
12B-1	281 000 005	281 000 006
06B-2	281 000 007	281 000 008
08B-2	281 000 009	281 000 010
10B-2	281 000 011	281 000 012

#### Attachment

- Installed underneath the chain
- Bore holes in the housing (for matching fastening brackets refer to pages 124 – 125)

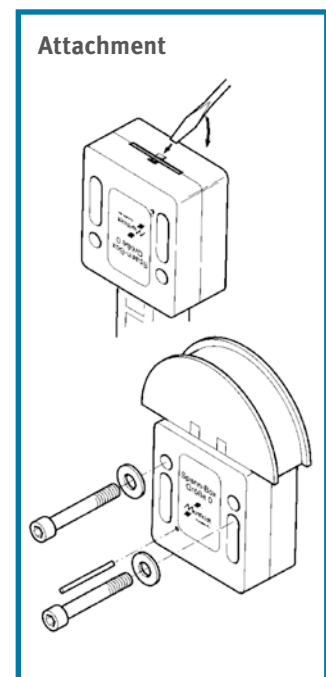
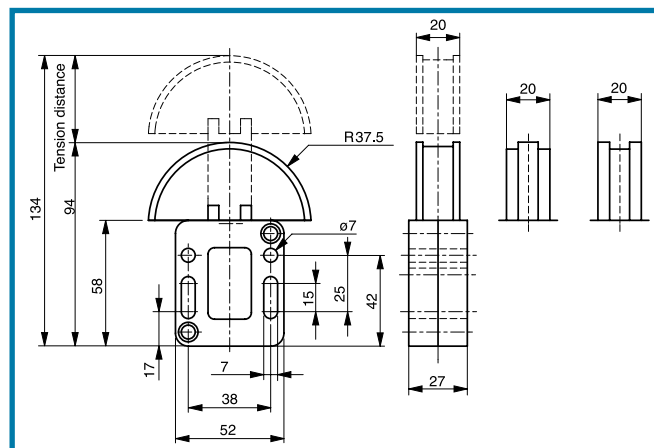



# SPANN-BOX® SIZE 30

## Three tension pressure settings

Spann-Box® size 30 provides high quality at the same time as being economically priced. The robust plastic housing gives high resistance to corrosion.

		Light	Heavy
Tension force	1 released spring	58 – 32 N	132 – 60 N
	2 released springs	116 – 64 N	264 – 120 N
	3 released springs	174 – 96 N	396 – 180 N
	Tension distance	40 mm	40 mm

# SPANN-BOX® SIZE 30

with arc segment profile

## Stainless steel screws and springs



### Applications

- Environments with a risk of corrosion
- No high mechanical stresses

### Tensioning pressure

- Choice of light or heavy spring force

### Attachment

- Installed underneath the chain
- Bore holes in the housing (for matching fastening brackets refer to pages 124 – 125)

DIN 8187 chain no.	B mm	Light tension force Article no.	Heavy tension force Article no.
≤06B-1 (U-Profile)	20	281 030 001	281 030 002
08B-1	20	281 030 003	281 030 004
10B-1	20	281 030 005	281 030 006
12B-1	20	281 030 007	281 030 008
16B-1	20	281 030 009	281 030 010
05B-2	20	281 030 011	281 030 012
06B-2	20	281 030 013	281 030 014
08B-2	20	281 030 015	281 030 016
10B-2	25	281 030 017	281 030 018
12B-2	30	281 030 019	281 030 020
05B-3	20	281 030 021	281 030 022
06B-3	25	281 030 023	281 030 024
08B-3	30	281 030 025	281 030 026
10B-3	40	281 030 027	281 030 028
12B-3	45	281 030 029	281 030 030

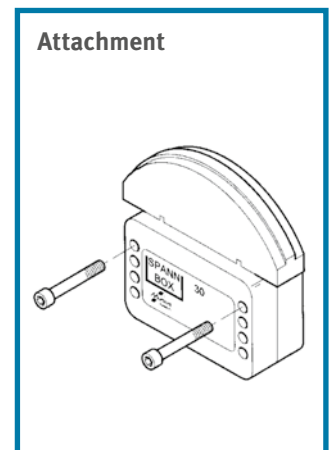
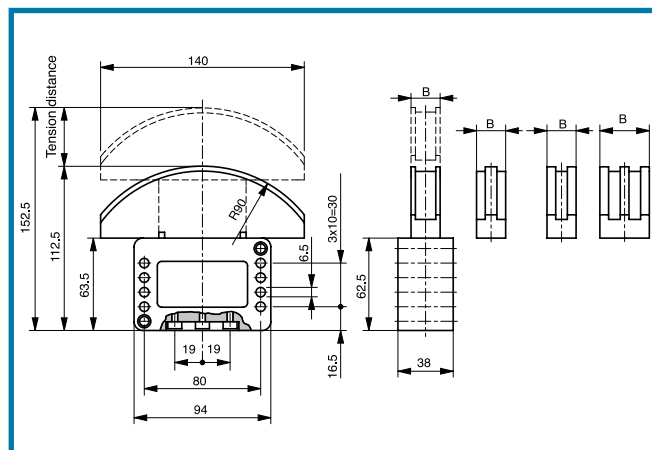

# SPANN-BOX® SIZE 1

## Three tension pressure settings

Spann-Box® size 1 is available in several variants. The robust design with its steel housing guarantees durability and reliable operation. We offer a total of five different designs to meet individual requirements.

### Reverse operation

If the running direction changes, we recommend using the appropriate Spann-Box® size with a long housing. We deliver this variant with heavy tension force.

		Light	Heavy
Tension force	1 released spring	58 – 32 N	132 – 60 N
	2 released springs	116 – 64 N	264 – 120 N
	3 released springs	174 – 96 N	396 – 180 N
	Tensioning distance	40 mm	40 mm

# SPANN-BOX® SIZE 1

## with arc segment profile



### Tensioning pressure

- Choice of light or heavy spring force

### Attachment

- Installed underneath the chain
- Bore holes in the housing (for matching fastening brackets refer to pages 124 – 125)

DIN 8187 chain no.	B mm	Short housing, light tension force article no.	Short housing, heavy tension force article no.	Long housing, heavy tension force article no.	Stainless steel, heavy tension force, short housing article no.	Stainless steel, heavy tension force, long housing article no.
≤06B-1 (U-Profile)	20	281 010 001	281 010 002	281 010 202	282 010 002	282 010 202
08B-1	20	281 010 003	281 010 004	281 010 204	282 010 004	282 010 204
10B-1	20	281 010 005	281 010 006	281 010 206	282 010 006	282 010 206
12B-1	20	281 010 007	281 010 008	281 010 208	282 010 008	282 010 208
16B-1	20	281 010 009	281 010 010	281 010 210	282 010 010	282 010 210
20B-1	20	281 010 011	281 010 012	281 010 212	282 010 012	282 010 212
06B-2	20	281 010 013	281 010 014	281 010 214	282 010 014	282 010 214
08B-2	20	281 010 015	281 010 016	281 010 216	282 010 016	282 010 216
10B-2	25	281 010 017	281 010 018	281 010 218	282 010 018	282 010 218
12B-2	30	281 010 019	281 010 020	281 010 220	282 010 020	282 010 220
16B-2	45	281 010 021	281 010 022	281 010 222	282 010 022	282 010 222
06B-3	25	281 010 023	281 010 024	281 010 224	282 010 024	282 010 224
08B-3	30	281 010 025	281 010 026	281 010 226	282 010 026	282 010 226
10B-3	40	281 010 027	281 010 028	281 010 228	282 010 028	282 010 228
12B-3	45	281 010 029	281 010 030	281 010 230	282 010 030	282 010 230

Special designs on request

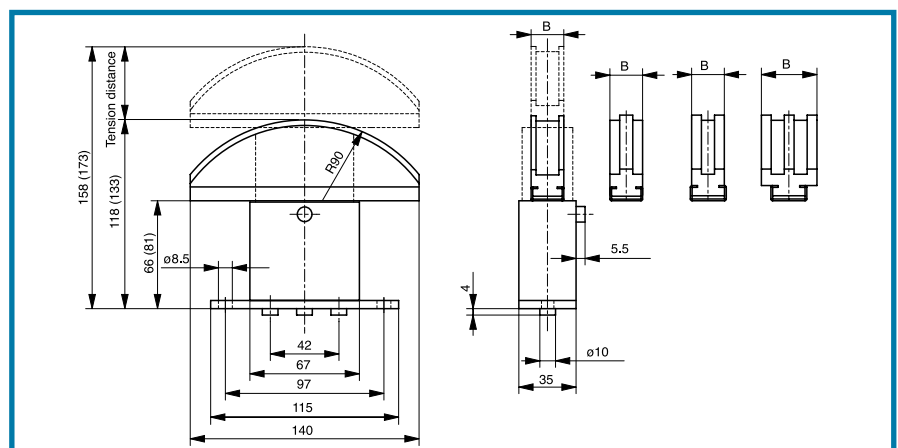

Clamp dimensions (...) for long housing

# SPANN-BOX® SIZE 1

with semi-circular profile

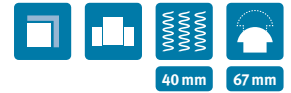

## Applications

- For restricted installation spaces

## Tensioning pressure

- Choice of light or heavy spring force

## Attachment

- Easier assembly thanks to mounting bracket
- Bore holes in the housing (for matching fastening brackets refer to pages 124–125)

DIN 8187 chain no.	B mm	Short housing, light tension force article no.	Short housing, heavy tension force article no.	Long housing, heavy tension force article no.	Stainless steel, heavy tension force, short housing article no.	Stainless steel, heavy tension force, long housing article no.
06B-1	30	281 010 031	281 010 032	281 010 232	282 010 032	282 010 232
08B-1	30	281 010 033	281 010 034	281 010 234	282 010 034	282 010 234
10B-1	30	281 010 035	281 010 036	281 010 236	282 010 036	282 010 236
12B-1	30	281 010 037	281 010 038	281 010 238	282 010 038	282 010 238
06B-2	30	281 010 039	281 010 040	281 010 240	282 010 040	282 010 240
08B-2	30	281 010 041	281 010 042	281 010 242	282 010 042	282 010 242
10B-2	30	281 010 043	281 010 044	281 010 244	282 010 044	282 010 244
12B-2	30	281 010 045	281 010 046	281 010 246	282 010 046	282 010 246
06B-3	30	281 010 047	281 010 048	281 010 248	282 010 048	282 010 248
08B-3	30	281 010 049	281 010 050	281 010 250	282 010 050	282 010 250

Special designs on request

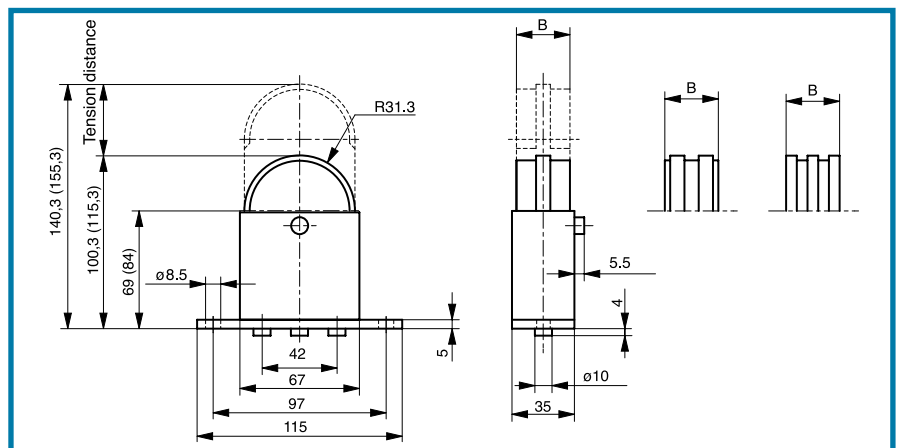

Clamp dimensions (...) for long housing

# SPANN-BOX® SIZE 1

with 180° return profile

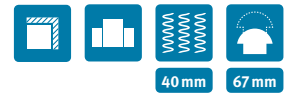

If the Spann-Box has been properly fitted, the double length of the Spann-Box's tension distance can be used to compensate for chain extension. For more examples see page 123.

## Tensioning pressure

- Heavy spring force

## Attachment

- Easier assembly thanks to fastening bracket
- Bore holes in the housing  
(for matching fastening brackets refer to pages 124 – 125)



DIN 8187 chain no.	B mm	Long housing, heavy tension force article no.	Stainless steel, long housing, heavy tension force article no.
06B-1	30	281 010 051	282 010 051
08B-1	30	281 010 052	282 010 052
10B-1	30	281 010 053	282 010 053
12B-1	30	281 010 054	282 010 054
16B-1	30	281 010 055	282 010 055
06B-2	30	281 010 056	282 010 256
08B-2	30	281 010 057	282 010 257
10B-2	30	281 010 058	282 010 258
12B-2	30	281 010 059	282 010 259
06B-3	30	281 010 060	282 010 260
08B-3	30	281 010 061	282 010 261

Special designs on request

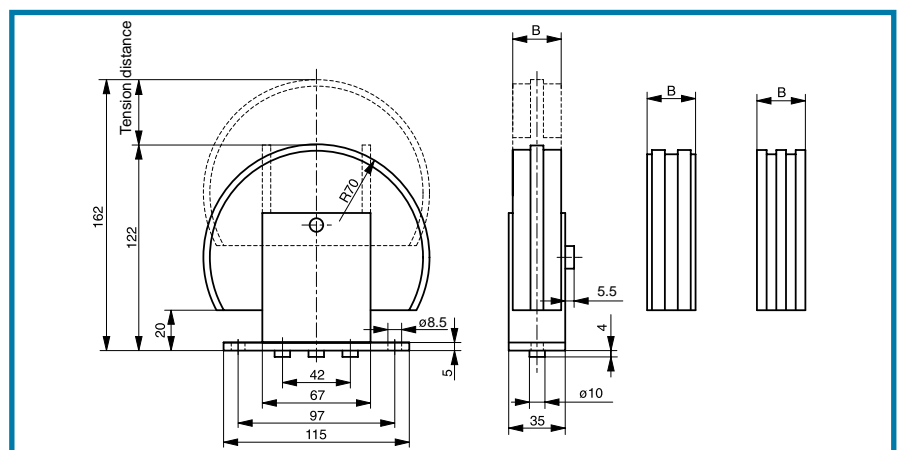

# SPANN-BOX® SIZE 1

## with sprocket type K-L/ Type K-S

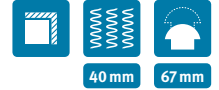

Spann-Box® size 1 with sprocket is used where space is restricted or there are high chain speeds ( $> 1\text{ m/s}$ ).

### Applications

- High chain speeds
- Small return radii
- Compensation for high chain elongation

### Tensioning pressure

- Heavy spring force

### Attachment

- Easier assembly thanks to mounting bracket
- Bore holes in the housing (for matching fastening brackets refer to pages 124 – 125)

DIN 8187 chain no.	No. of teeth	Type K-L heavy tension force article no.	Type K-S heavy tension force article no.
06B-1	20	281 210 005	281 210 001
06B-1	21	281 210 011	281 210 022
06B-1	23	281 210 012	281 210 023
08B-1	16	281 210 014	281 210 024
08B-1	17	281 210 006	281 210 025
08B-1	18	281 210 015	281 210 002
10B-1	14	281 210 016	281 210 026
10B-1	15	281 210 017	281 210 027
10B-1	16	281 210 007	281 210 028
10B-1	17	281 210 018	281 210 003
12B-1	13	281 210 033	281 210 029
12B-1	14	281 210 019	281 210 030
12B-1	15	281 210 008	281 210 004
12B-1	16	281 210 020	281 210 031
12B-1	17	281 210 021	281 210 032

Special and stainless steel designs on request

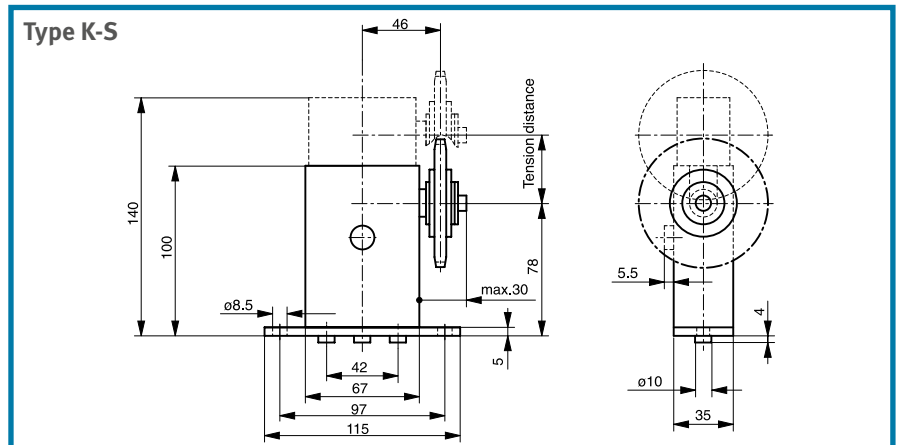
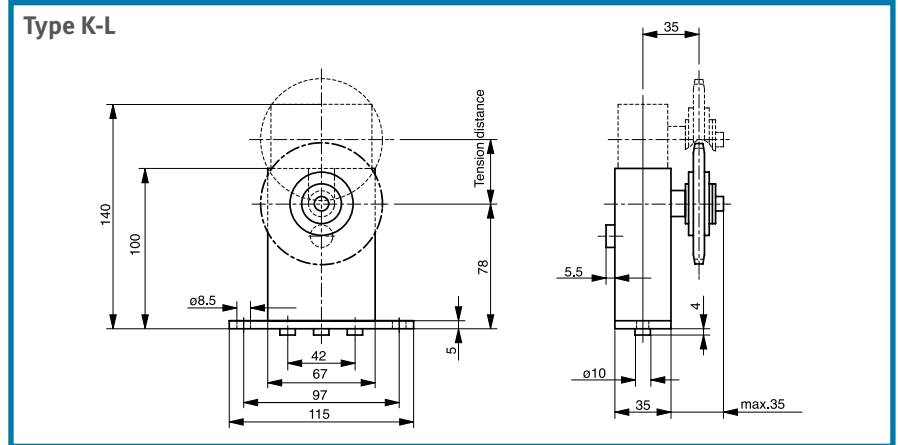

# SPANN-BOX® SIZE 2

## Three tension pressure settings

Like Spann-Box® size 1, Spann-Box® size 2 is available in different variants. The steel housing guarantees durability and reliability.

### Reverse operation

If the running direction changes, we recommend using the appropriate Spann-Box® size with a long housing. We deliver this variant with heavy tension force.

	Light	Heavy	
Tension force	1 released spring	148 – 82 N	262 – 118 N
	2 released springs	296 – 164 N	524 – 236 N
	3 released springs	444 – 246 N	786 – 354 N
Tension distance	60 mm	60 mm	

# SPANN-BOX® SIZE 2

## with arc segment profile

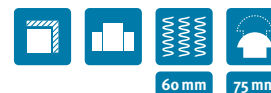

### Tensioning pressure

- Choice of light or heavy spring force

### Attachment

- Easier assembly thanks to mounting bracket
- Bore holes in the housing (for matching fastening brackets refer to pages 124 – 125)

DIN 8187 chain no.	B mm	Long housing, light tension force, Article no.	Long housing, heavy tension force Article no.	Stainless steel, long housing, heavy tension force Article no.
12B-1	25	281 020 201	281 020 202	282 020 202
16B-1	25	281 020 203	281 020 204	282 020 204
20B-1	25	281 020 205	281 020 206	282 020 206
24B-1	30	281 020 207	281 020 208	282 020 208
08B-2	25	281 020 209	281 020 210	282 020 210
10B-2	25	281 020 211	281 020 212	282 020 212
12B-2	30	281 020 213	281 020 214	282 020 214
16B-2	45	281 020 215	281 020 216	282 020 216
20B-2	55	281 020 217	281 020 218	282 020 218
24B-2	70	281 020 219	281 020 220	282 020 220
08B-3	30	281 020 221	281 020 222	282 020 222
10B-3	40	281 020 223	281 020 224	282 020 224
12B-3	45	281 020 225	281 020 226	282 020 226
16B-3	75	281 020 227	281 020 228	282 020 228
20B-3	90	281 020 229	281 020 230	282 020 230

Special designs on request

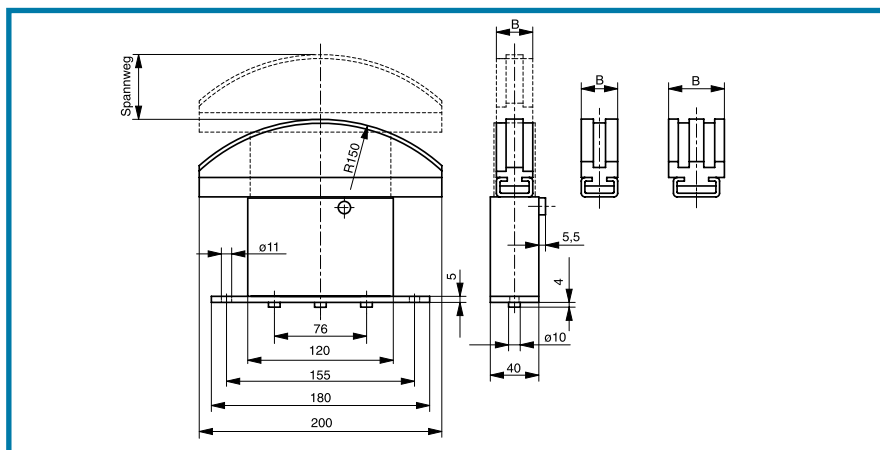

Clamp dimensions (...) for long housing



# SPANN-BOX® SIZE 2

with semi-circular profile

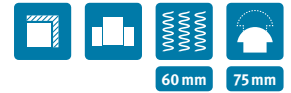

## Applications

- For restricted installation spaces

## Tensioning pressure

- Choice of light or heavy spring force

## Attachment

- Easier assembly thanks to mounting bracket
- Bore holes in the housing (for matching fastening brackets refer to pages 124–125)

DIN 8187 chain no.	B mm	Long housing, light tension force, Article no.	Long housing, heavy tension force, Article no.	Stainless steel, long housing, heavy tension force, Article no.
12B-1	33	281 020 231	281 020 232	282 020 232
16B-1	33	281 020 233	281 020 234	282 020 234
08B-2	33	281 020 235	281 020 236	282 020 236
10B-2	33	281 020 237	281 020 238	282 020 238
12B-2	33	281 020 239	281 020 240	282 020 240
08B-3	33	281 020 241	281 020 242	282 020 242
10B-3	40	281 020 243	281 020 244	282 020 244

Special designs on request

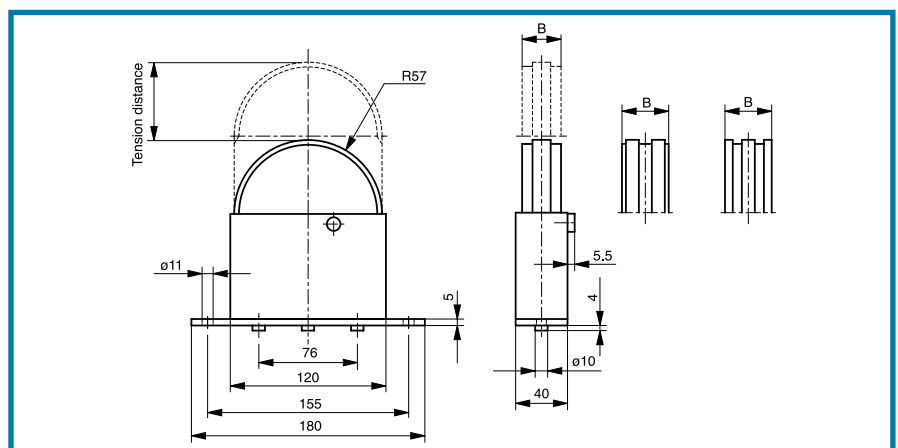

Clamp dimensions (...) for long housing

# SPANN-BOX® SIZE 2

with 180° return profile

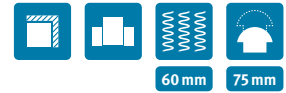

With the appropriate installation, the double tension distance length can be used for chain elongation. Further installation examples see page 117.

## Tensioning pressure

- Heavy spring force

## Attachment

- Easier assembly thanks to mounting bracket
- Bore holes in the housing (for matching fastening brackets refer to pages 124 – 125)



DIN 8187 chain no.	B mm	Long housing, heavy tension force Article no.	Stainless steel, long housing, heavy tension force Article no.
12B-1	33	281 020 045	282 020 045
16B-1	33	281 020 046	282 020 046
20B-1	33	281 020 047	282 020 047
08B-2	33	281 020 048	282 020 048
10B-2	33	281 020 049	282 020 049
12B-2	33	281 020 050	282 020 050
08B-3	33	281 020 051	282 020 051
10B-3	40	281 020 052	282 020 052
12B-3	45	281 020 053	282 020 053

Special designs on request

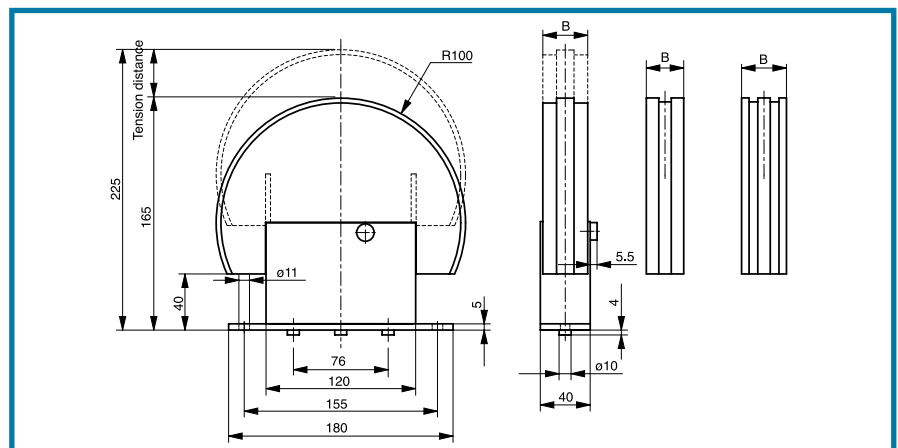

# SPANN-BOX® SIZE 2

with block profile

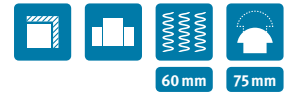

This design is ideally suited for heavy loads. It is intended for use with high dynamic forces.

## Design

- Slide profile and tension core made from a single piece

## Tensioning pressure

- Heavy spring force

## Attachment

- Easier assembly thanks to mounting bracket
- Bore holes in the housing (for matching fastening brackets refer to pages 124 – 125)

DIN 8187 chain no.	B mm	Long housing, heavy tension force Article no.	Stainless steel, long housing, heavy tension force Article no.
24B-1	33	281 020 054	282 020 054
28B-1	33	281 020 055	282 020 055
32B-1	33	281 020 056	282 020 056
40B-1	40	281 020 057	282 020 057
48B-1	45	281 020 058	282 020 058
16B-2	45	281 020 059	282 020 059
20B-2	55	281 020 060	282 020 060
24B-2	70	281 020 061	282 020 061
16B-3	75	281 020 062	282 020 062
20B-3	90	281 020 063	282 020 063

Special designs on request

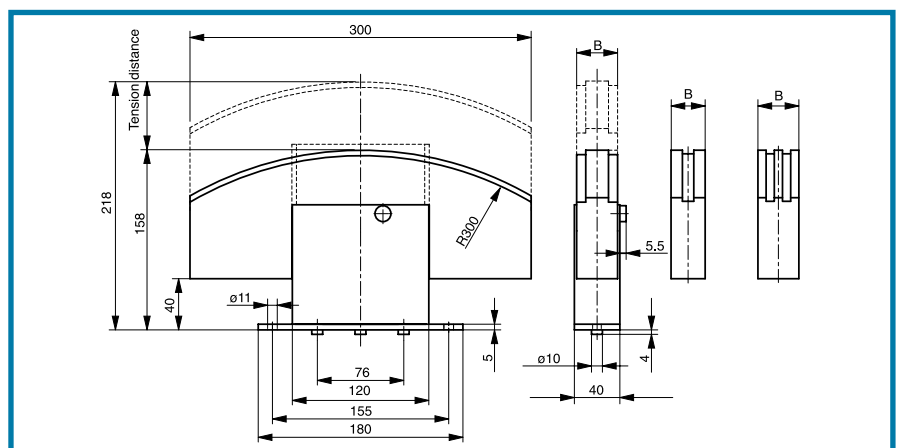

# AUTOMATIC BELT TENSIONERS

Round belts, V-belts as per DIN 2215, or flat belts – they all require different pre-tensioning. The following Spann-Box®/ Spann-Boy® types are available as belt tensioners

- Spann-Boy®TS
- Spann-Box® size 0
- Spann-Box® size 1

## Material

We use our tried-and-tested Original Material "S"™ Black Antistatic for the ball-bearing supported tensioning roller that is attached to the housing. It is characterized by its excellent wear resistance, ideal slide properties, and very good resistance to chemicals.

## Design

Our tensioning rollers come with a cylindrical surface or a profile of your choice. Use the profile shape table to specify the required profile along with the belt type used when you make your order.

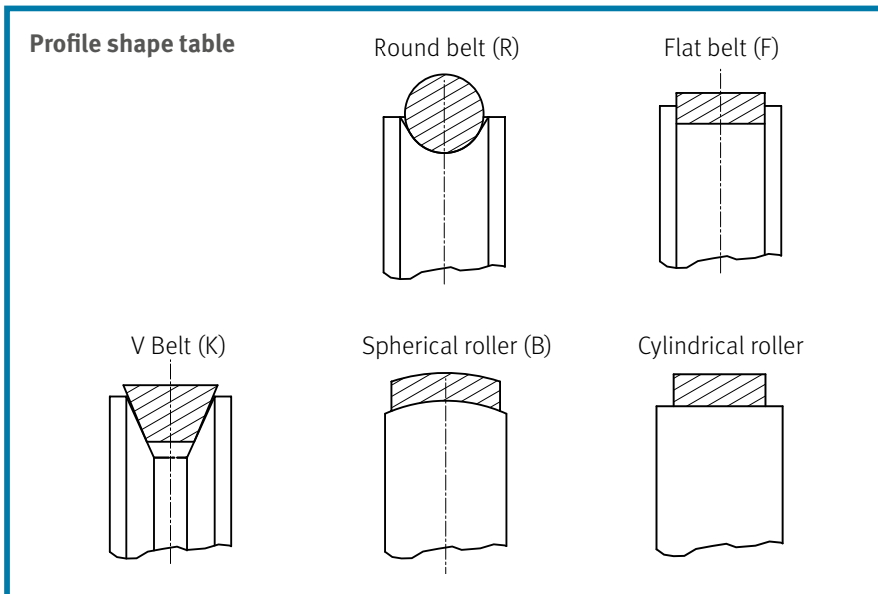

		Light tension force	Heavy tension force	Tension distance
Spann-Box® size 0 with roller	1 released spring	58 – 32 N	132 – 60 N	40 mm
Spann-Boy® TS with roller	1 released spring	58 – 32 N	132 – 60 N	40 mm
	2 released springs	190 – 96 N		40 mm
Spann-Box® size 1 Type SR-0 tensioning roller on top Type SR-L tensioning roller on long side Type SR-S tensioning roller on front	1 released spring	58 – 32 N	132 – 60 N	40 mm
	2 released springs	116 – 64 N	264 – 120 N	40 mm
	3 released springs	174 – 96 N	396 – 180 N	40 mm



# SPANN-BOY® TS AS BELT TENSIONER

with roller

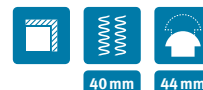

Three tension pressure settings

## Tension pressure

- Spann-Boy® TS has one light and one heavy pressure spring that can be released together or separately depending on the required tension pressure.

## Attachment

- Bore holes in the housing (for matching fastening brackets refer to pages 124 – 125)

Roller width mm	Profile shape	Article no.
20	Cylindrical	281 160 001
	Spherical	281 160 004
	Flat belt	281 160 007
	V-belt	281 160 010
	Round belt	281 160 013
30	Cylindrical	281 160 002
	Spherical	281 160 005
	Flat belt	281 160 008
	V-belt	281 160 011
	Round belt	281 160 014
40	Cylindrical	281 160 003
	Spherical	281 160 006
	Flat belt	281 160 009
	V-belt	281 160 012
	Round belt	281 160 015

Special and stainless steel designs on request

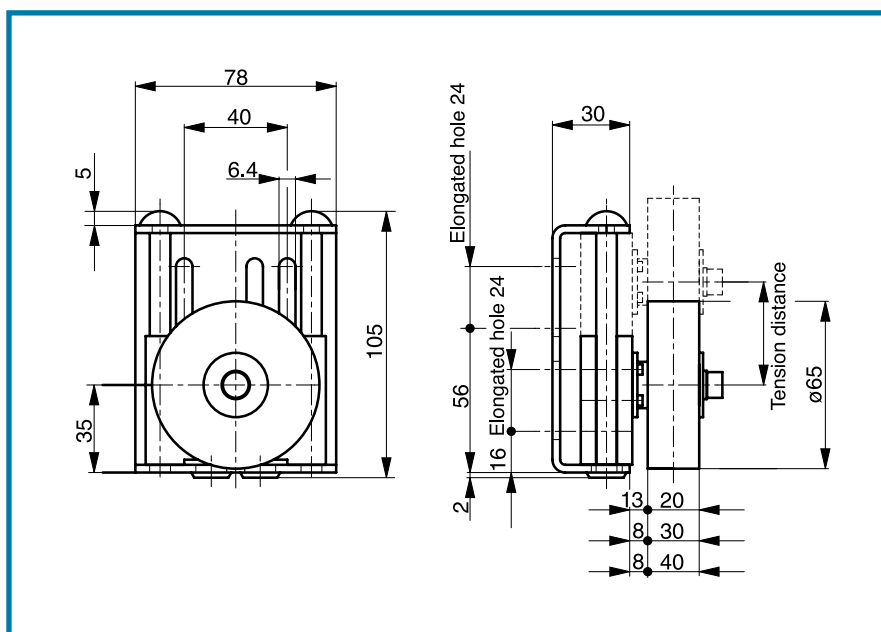

# SPANN-BOX® SIZE 0 AS BELT TENSIONER

with roller



## Design

- Corrosion-proof housing

## Tensioning pressure

- Choice of light or heavy spring force

Roller width mm	Profile shape	Light tension force Article no.	Heavy tension force Article no.
20	Cylindrical	281 100 001	281 100 002
	Spherical	281 100 007	281 100 008
	Flat belt	281 100 013	281 100 014
	V-belt	281 100 019	281 100 020
	Round belt	281 100 025	281 100 026
30	Cylindrical	281 100 003	281 100 004
	Spherical	281 100 009	281 100 010
	Flat belt	281 100 015	281 100 016
	V-belt	281 100 021	281 100 022
	Round belt	281 100 027	281 100 028
40	Cylindrical	281 100 005	281 100 006
	Spherical	281 100 011	281 100 012
	Flat belt	281 100 017	281 100 018
	V-belt	281 100 023	281 100 024
	Round belt	281 100 029	281 100 030

Special and stainless steel designs on request

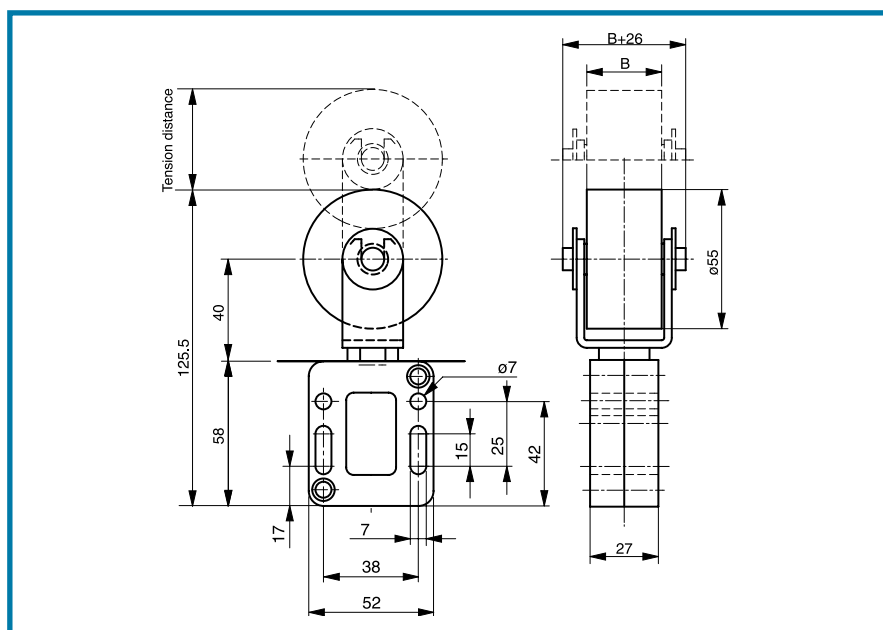



# SPANN-BOX® SIZE 1 AS BELT TENSIONER

Our tried-and-tested Spann-Box® is ideally suited for use as a belt tensioner. We offer different designs for different scenarios. The variants differ primarily in the mounting of the tensioning roller. The basic design is identical for all variants.

## Tensioning pressure

- Choice of light or heavy spring force

## Attachment

- Bore holes in the housing (for matching fastening brackets refer to pages 124 – 125)

## SPANN-BOX® SIZE 1 TYPE SR-O

as belt tensioner with roller on top

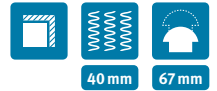

Roller width mm	Profile shape	Light tension force Article no.	Heavy tension force Article no.
53	Cylindrical	281 110 001	281 110 002
	Spherical	281 110 003	281 110 004
	Flat belt	281 110 005	281 110 006
	V-belt	281 110 007	281 110 008
	Round belt	281 110 009	281 110 010

Special and stainless steel designs on request

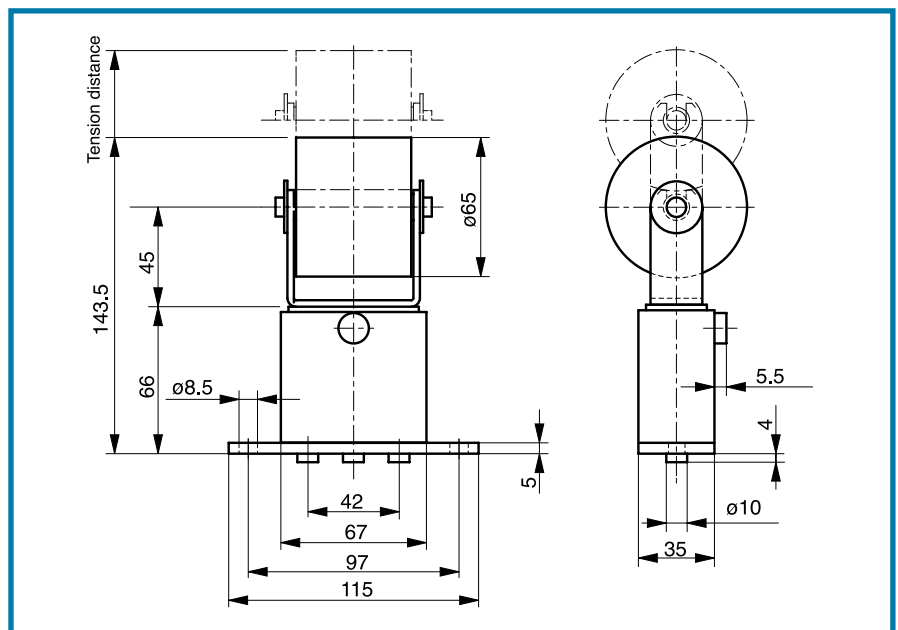

# SPANN-BOX® SIZE 1 / TYPE SR-L

Tensioning roller on long side

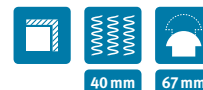

Roller width mm	Profile shape	Light tension force Article no.	Heavy tension force Article no.
20	Cylindrical	281 110 011	281 110 012
	Spherical	281 110 017	281 110 018
	Flat belt	281 110 023	281 110 024
	V-belt	281 110 029	281 110 030
	Round belt	281 110 035	281 110 036
30	Cylindrical	281 110 013	281 110 014
	Spherical	281 110 019	281 110 020
	Flat belt	281 110 025	281 110 026
	V-belt	281 110 031	281 110 032
	Round belt	281 110 037	281 110 038
40	Cylindrical	281 110 015	281 110 016
	Spherical	281 110 021	281 110 022
	Flat belt	281 110 027	281 110 028
	V-belt	281 110 033	281 110 034
	Round belt	281 110 039	281 110 040

Special and stainless steel designs on request

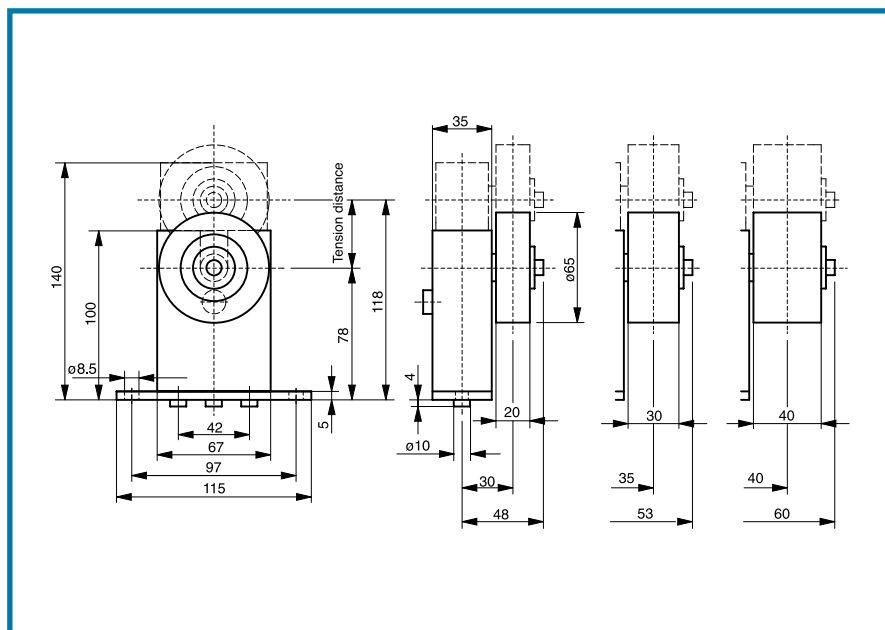

# SPANN-BOX® SIZE 1 / TYPE SR-S

Tensioning roller on front

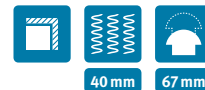

Roller width mm	Profile shape	Light tension force Article no.	Heavy tension force Article no.
20	Cylindrical	281 110 041	281 110 042
	Spherical	281 110 047	281 110 048
	Flat belt	281 110 053	281 110 054
	V-belt	281 110 059	281 110 060
	Round belt	281 110 065	281 110 066
30	Cylindrical	281 110 043	281 110 044
	Spherical	281 110 049	281 110 050
	Flat belt	281 110 055	281 110 056
	V-belt	281 110 061	281 110 062
	Round belt	281 110 067	281 110 068
40	Cylindrical	281 110 045	281 110 046
	Spherical	281 110 051	281 110 052
	Flat belt	281 110 057	281 110 058
	V-belt	281 110 063	281 110 064
	Round belt	281 110 069	281 110 070

Special and stainless steel designs on request

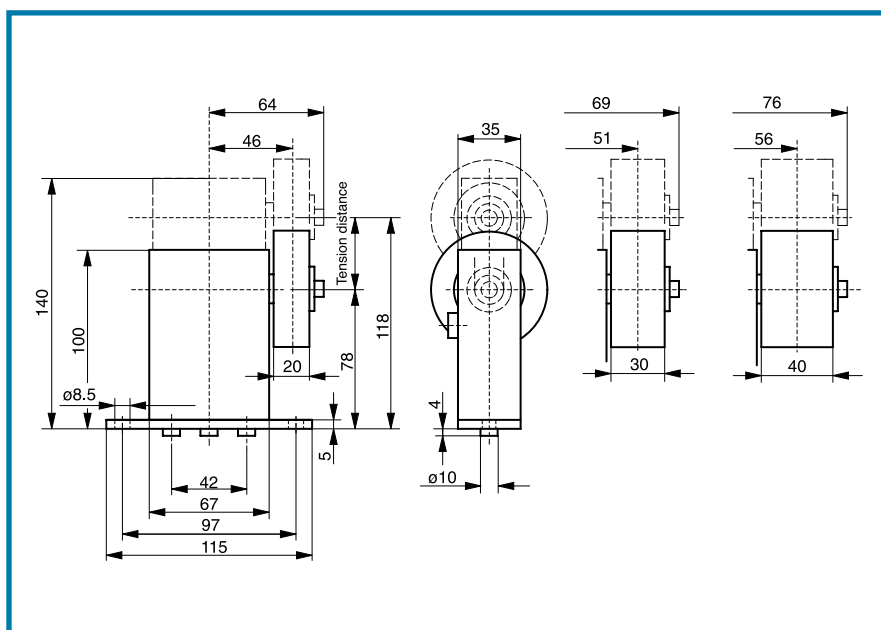

## SPECIAL TENSIONERS

The requirements of our customers are diverse. No pool of machinery is the same as another, so the enquiries we receive are often extremely individual. We will do everything possible to meet your demands with our special models. Correct advice is absolutely vital here – it's what makes our components reliable.

### A variety of influences

The work conditions must be known in detail in order for the best tensioning

system for your machines to be determined. A host of factors can restrict functionality, such as force effects, chain speed, chain pressure, contamination, and temperature. The use of machinery in problematic temperature ranges can often result in a high risk of malfunction or damage.

This makes it vital for you to receive the best possible advice on the correct choice of material. Please contact our

application technology department. We will be glad to work with you to find a custom solution.

[technik@murfeldt.de](mailto:technik@murfeldt.de)

Feel free to use also our design questionnaire at [www.murfeldt.com](http://www.murfeldt.com).



Spann-Box® size 2 for use at temperatures of up to 200°C



Spann-Box® size 1 for use at temperatures of up to 150°C



Spann-Box® size 30, with mechanical limit switch



The double-tensioner for chain drives with reverse operation. Thanks to the „floating“ suspension of the clamping elements, the tension is always applied just where it's needed: On the slack strand.



Spann-Box® size 1 with return profile made of Murinit® SP in accordance with customer's requirements



Ω-tension station for compensation of extensive chain lengthening



Size 1 tension station with roller



Spann-Box® size 1 with arc segment made from Original Material "S"®plus+OIL for an accumulator chain



Spann-Box® size 1 or size 2, tandem tensioner for tensioning chains with extremely large chain pitches



Spann-Box® designs with locking devices; they prevent the slide profile from being compressed when the direction of rotation changes, for example.







# TECHNICAL INFORMATION

# SHEET DIMENSIONS

Plastics	Thickness	Width	Length	Thickness tolerance
Original Material "S" green	2/3/4/5/6	1000	2000	+0/+0,8
Semi-finished product according to ISO 15527 sheet group 1.2	8 – 200	1000	2000	+0/+0,6
	2/3/4/5/6	1220	3000	+0/+0,8
	8 – 120	1000	3000	+0/+0,6
	8 – 120	1000	4000	+0/+0,6
	8 – 120	1335	2000	+0/+0,6
	8 – 100	1000	2500	+0/+0,6
	8 – 100	1250	3000	+0/+0,6
	8 – 100	1250	6000	+0/+0,6
	8 – 100	2500	6000	+0/+0,6
Original Material "S" natural	1/2/3/4/5/6	1000	2000	+0/+0,8
Semi-finished product according to ISO 15527 sheet group 1.2	8 – 200	1000	2000	+0/+0,6
	2/3/4/5	1220	3000	+0/+0,8
	10 – 120	1000	3000	+0/+0,6
	8 – 120	1000	4000	+0/+0,6
	8 – 100	1000	2500	+0/+0,6
	8 – 100	1250	3000	+0/+0,6
	8 – 100	1250	6000	+0/+0,6
	8 – 100	2500	6000	+0/+0,6
	Original Material "S" black antistatic	1/2/3/4/5/6	1000	2000
Semi-finished product according to ISO 15527 sheet group 1.2	8 – 200	1000	2000	+0/+0,6
	2/3/4/5/6	1220	3000	+0/+0,8
	8 – 120	1000	3000	+0/+0,6
	8 – 120	1000	4000	+0/+0,6
	8 – 120	1335	2000	+0/+0,6
	8 – 100	1000	2500	+0/+0,6
	8 – 100	1250	3000	+0/+0,6
	8 – 100	1250	6000	+0/+0,6
	8 – 100	2500	6000	+0/+0,6
Original Material "S" coloured	8 – 100	1000	2500	+0/+0,6
	8 – 100	1250	3000	+0/+0,6
	8 – 100	1250	6000	+0/+0,6
	8 – 100	2500	6000	+0/+0,6
Material "S" 1000green	3/4/5/6	1000	2000	+0/+0,8
	8 – 200	1000	2000	+0/+0,6
	3/4/5/6	1220	3000	+0/+0,8
	8 – 100	1000	3000	+0/+0,6
	10 – 120	1335	2000	+0/+0,6
	10 – 120	1000	4000	+0/+0,6
	8 – 100	1000	2500	+0/+0,6
	8 – 100	1250	3000	+0/+0,6
	8 – 100	1250	6000	+0/+0,6
8 – 100	2500	6000	+0/+0,6	
Material "S" 1000black antistatic	2 – 6	1000	2000	+0/+0,8
	8 – 200	1000	2000	+0/+0,6
	3/4/5/6	1220	3000	+0/+0,8
	8 – 100	1000	3000	+0/+0,6
	10 – 100	1335	2000	+0/+0,6
	10 – 120	1000	4000	+0/+0,6
	8 – 100	1000	2500	+0/+0,6
	8 – 100	1250	3000	+0/+0,6
	8 – 100	1250	6000	+0/+0,6
8 – 100	2500	6000	+0/+0,6	

**NEW!** on request

**NEW!** on request

**NEW!** on request

**NEW!** on request

**NEW!** on request

Most of these sheets are available from stock. Should any of these materials not be in stock, we will of course be able to supply them at short notice. Please contact us, we will be pleased to assist you!

# SHEET DIMENSIONS

Plastics	Thickness	Width	Length	Thickness tolerance
Muralen <sup>®</sup> green	Not standard warehouse stock, available on request			as per DIN EN 14632
Muralen <sup>®</sup> black antistatic	8 – 100	1000	2000	+0/+0,6
Muralen <sup>®</sup> coloured	Not standard warehouse stock, available on request. Ex-stock in blue RAL5017/10, 20,30, 40 mm			
Muralen <sup>®</sup> plus + AB	8 – 110	1000	2000	+0/+0,6
Original Material "S"plus + <sup>®</sup> ESD	8 – 110	1000	2000	+0/+0,6
<b>NEW!</b> on request	8 – 100	1000	2500	+0/+0,6
	8 – 100	1250	3000	+0/+0,6
	8 – 100	1250	6000	+0/+0,6
	8 – 100	2500	6000	+0/+0,6
	Original Material "S"plus + <sup>®</sup> Bright ESD	8 – 110	1000	2000
Original Material "S"plus + <sup>®</sup> LF	8 – 120	1000	2000	+0/+0,6
Original Material "S"plus + <sup>®</sup> LF ESD	8 – 100	1000	2000	+0/+0,6
Original Material "S"plus + <sup>®</sup> LFP ESD	8 – 40	1000	2000	+0/+0,6
Material "S"8000 <sup>®</sup>	8 – 130	1000	2000	+0/+0,6
Original Material "S"plus + <sup>®</sup> AB	8 – 110	1000	2000	+0/+0,6
Original Material "S"plus + <sup>®</sup> FP [FS] <sup>®</sup>	10 – 60	1335	2000	+0/+0,6
Original Material "S"plus + <sup>®</sup> GB	8 – 110	1000	2000	+0/+0,6
Original Material "S"plus + <sup>®</sup> TLS	8 – 100	1000	2000	+0/+0,6
Murlubric <sup>®</sup>	8 – 100	1000	2000	+0/+0,6
	110 – 160	1000	1000	+0/+0,6
Murlubric <sup>®</sup> blue [FS] <sup>®</sup>	10 – 100	1000	2000	as per DIN EN 15860
Murylon <sup>®</sup> 6 Cast natural/black	10 – 100	1000	2000	as per DIN EN 15860
Murdopol <sup>®</sup>	10 – 50	1000	2000	on request
Murylon <sup>®</sup> B natural	2 – 60	1000	2000	as per DIN EN 15860
	70 – 100	610	2000	as per DIN EN 15860
Murylon <sup>®</sup> B black	8 – 50	610	2000	as per DIN EN 15860
Murylon <sup>®</sup> A natural	8 – 60	610	2000	as per DIN EN 15860
Murylon <sup>®</sup> A black	10 – 50	500	2000	as per DIN EN 15860
Murylon <sup>®</sup> A GF black	10 – 100	625	2000	as per DIN EN 15860
Murytal <sup>®</sup> C natural	1 – 100	1000	2000	as per DIN EN 15860
Murytal <sup>®</sup> C black	2 – 100	1000	2000	as per DIN EN 15860
Murytal <sup>®</sup> C blue [FS] <sup>®</sup>	10 – 100	1000	2000	as per DIN EN 15860
Murytal <sup>®</sup> H natural/black	10 – 50	610	2000	as per DIN EN 15860
Murytal <sup>®</sup> ESD black	10 – 60	500	2000	as per DIN EN 15860
Murylat <sup>®</sup> natural	8 – 100	610	2000	as per DIN EN 15860
Murylat <sup>®</sup> black	8 – 80	610	2000	as per DIN EN 15860
Murylat <sup>®</sup> SP	8 – 100	610	2000	as per DIN EN 15860
Murylon <sup>®</sup> HT	10 – 40	610	2000	as per DIN EN 15860
	50	500	2000	as per DIN EN 15860
Murinyl <sup>®</sup>	10 – 80	610	2000	as per DIN EN 15860
Murflor <sup>®</sup>	3 – 50	1000	1000	as per GKV
	10 – 50	1000	2000	as per GKV
Murflor <sup>®</sup> Carbon	10 – 40	1000	2000	as per GKV
Murflor <sup>®</sup> Bronze	10 – 30	1000	2000	as per GKV
Murflor <sup>®</sup> Glass	10 – 30	1000	2000	as per GKV
Murinit <sup>®</sup> SP	8/10	525	2000	as per DIN EN 15860
	12 – 50	625	2000	as per DIN EN 15860
Murpec <sup>®</sup>	5 – 25	1000	2000	as per DIN EN 15860
	30 – 60	615	2000	as per DIN EN 15860
Murpec <sup>®</sup> SP	10	525	2000	as per DIN EN 15860
	16/20/30/40	625	2000	as per DIN EN 15860

Sheet sizes in mm  
Tolerances: Widths and lengths  $\geq +0$  mm, as per DIN EN 15860 or as per GKV.

Other colours and dimensions (thickness x width x length) and other pre-cut parts on request

## ROD DIMENSIONS

Plastics	Diameter	Graduations	Length	Ø-tolerance
Original Material "S" green	10 – 100	5	1000	+0/+1
Semi-finished product according to ISO 15527 sheet group 1.2	100 – 200	10	1000	+0/+1
Original Material "S" natural	10 – 30	5	1000	+0/+1
Semi-finished product according to ISO 15527 sheet group 1.2	30 – 200	10	1000	+0/+1
Original Material "S" black antistatic	10 – 100	5	1000	+0/+1
Semi-finished product according to ISO 15527 sheet group 1.2	100 – 200	10	1000	+0/+1
Original Material "S" coloured	on request		1000	+0/+1
Material "S" 1000green	on request		1000	+0/+1
Material "S" 1000black antistatic	on request		1000	+0/+1
Muralen <sup>+</sup> green/natural/black antistatic	on request		1000	+0/+1
Muralen <sup>+</sup> coloured	on request		1000	+0/+1
Muralen <sup>+</sup> plus + AB	on request		1000	+0/+1
Material "S"8000 <sup>+</sup>	on request		1000	+0/+1
Original "S"plus + <sup>+</sup> Materials	on request		1000	+0/+1
Original Material "S" green <sup>+</sup> /natural/black (extruded)	20 – 100	10	2000	on request
Muralen <sup>+</sup> natural/black (extruded)	30 – 100	10	2000	on request
Murlubric <sup>+</sup>	20 – 100	5	1000	as per DIN EN 15860
	100 – 200	10	1000	as per DIN EN 15860
Murlubric <sup>+</sup> blue [FS] <sup>+</sup>	20 – 100	5	1000	as per DIN EN 15860
	100 – 200	10	1000	as per DIN EN 15860
Murylon <sup>+</sup> 6 Cast natural	50 – 500	#	1000	as per DIN EN 15860
Murylon <sup>+</sup> 6 Cast black	50 – 500	#	1000	as per DIN EN 15860
Murdopol <sup>+</sup> (rods with and without steel core)	50 – 200	10	500	on request
Murylon <sup>+</sup> B natural	5 – 100	#	1000	as per DIN EN 15860
Murylon <sup>+</sup> B black	10 – 100	#	1000	as per DIN EN 15860
Murylon <sup>+</sup> A natural	5 – 200	#	1000	as per DIN EN 15860
Murylon <sup>+</sup> A black	20 – 100	#	1000	as per DIN EN 15860
Murylon <sup>+</sup> A GF black	10 – 200	#	1000	as per DIN EN 15860
Murytal <sup>+</sup> C natural	3 – 200	#	1000	as per DIN EN 15860
Murytal <sup>+</sup> C black	5 – 200	#	1000	as per DIN EN 15860
Murytal <sup>+</sup> C blau [FS] <sup>+</sup>	15 – 200	#	1000	as per DIN EN 15860
Murytal <sup>+</sup> H natural	5 – 200	#	1000	as per DIN EN 15860
Murytal <sup>+</sup> H black	20 – 100	#	1000	as per DIN EN 15860
Murytal <sup>+</sup> ESD black	30 – 100	#	1000	as per DIN EN 15860
Murylat <sup>+</sup> natural	10 – 210	#	1000	as per DIN EN 15860
Murylat <sup>+</sup> black	20 – 150	#	1000	as per DIN EN 15860
Murylat <sup>+</sup> SP	10 – 150	#	1000	as per DIN EN 15860

Rod sizes in mm  
Tolerances: Widths and lengths  $\geq +0$  mm, as per DIN EN 15860 or as per GKV.

Other colours and dimensions (diameter and length) and other pre-cut parts and round discs on request. # Irregular graduations; please state required  $\phi$ . We will provide you with the suitable/next largest  $\phi$ .

## ROD DIMENSIONS

Plastics	Diameter	Graduations	Length	Ø-tolerance
Murylon® HT	16 – 60	#	1000	as per DIN EN 15860
Murinyl®	10 – 250	#	1000	as per DIN EN 15860
Murflor®	10 – 120	#	1000	as per GKV
Murflor®-Carbon	10 – 100	10	on request	as per GKV
Murflor®-Bronze	10 – 100	10	on request	as per GKV
Murflor®-Glass	10 – 100	10	on request	as per GKV
Murinit SP®	10 – 100	#	1000	as per DIN EN 15860
Murpec®	10 – 140	#	1000	as per DIN EN 15860
	150 – 200	#	1000	as per DIN EN 15860
Murpec® SP	8 – 100	#	1000	as per DIN EN 15860

Rod sizes in mm  
Tolerances: Widths and lengths  $\geq +0$  mm, as per DIN EN 15860 or as per GKV.

Other colours and dimensions (diameter and length) and other pre-cut parts and round discs on request. # Irregular graduations; please state required  $\emptyset$ . We will provide you with the suitable/next largest  $\emptyset$ .

## LEGEND

according to the following material characteristic tables

The material characteristic tables, which are based on data from our suppliers of raw materials, are intended to help you to quickly compare/select a material. The values stated are short-term values that can be affected by processing, environmental, and application conditions. The customer is solely responsible for the suitability of the selected material for the specific application.

+ Dry

++ Air-moist (saturation in standard atmosphere of 23°C / 50% RH)

RH Relative humidity

NB No break

 also available as Food Safe Material ref. EU 1935/2004 and EU 10/2011..

- 1) The mechanical and electrical characteristics are based on a test temperature of 23°C
- 2) Temperature stress for several hours; no or low mechanical stress (short-term service temperature)
- 3) Temperature stress for 5000h; then reduction (approx 50%) of tensile strength of initial value (constant: for 5000h)
- 4) As the temperature decreases, the impact strength drops. The specified values are based on the most unfavourable impact load possible and do not represent absolute practical limits (lower service temperature)
- 5) The electric strength can be up to 50% lower than for natural coloured materials (for black Murylon® B, Murylon® A, Murytal® C/H, and Murylat®)

### Chemical resistance of our materials:

For a detailed selection chart, see our Internet pages at [www.murtfeldt.com](http://www.murtfeldt.com).

## PRINT UPDATE

Up-to-date info regarding all available Murtfeldt print data can be found here: [murtfeldt.com/services/print-media-updates](http://murtfeldt.com/services/print-media-updates)

Here you can check online, if there are any changes to existing Murtfeldt catalogs, brochures and calendars.



## Characteristics

# MATERIAL "S"<sup>®</sup> GROUP

	Standard	Unit	Original Material "S" <sup>®</sup> green	Original Material "S" <sup>®</sup> natural	Orig. Material "S" <sup>®</sup> black antistatic	Material "S" <sup>®</sup> 1000 green	Material "S" <sup>®</sup> 1000 black antistatic	Muralen <sup>®</sup> green	Muralen <sup>®</sup> natural	Muralen <sup>®</sup> black antistatic	Muralen <sup>®</sup> coloured (available in various colours)	Muralen <sup>®</sup> plus+ AB
<b>Technical properties</b>												
Code	ISO 1043-1		PE-UHMW	PE-UHMW	PE-UHMW	PE-UHMW	PE-UHMW	PE-HMW	PE-HMW	PE-HMW	PE-HMW	PE-HMW
Material colour	–		green	natural	black	green	black	green	natural	black	–	sky blue
Average molecular weight	–	g/mol	5 × 10 <sup>6</sup>	5 × 10 <sup>6</sup>	5 × 10 <sup>6</sup>	–	–	0,5 × 10 <sup>6</sup>	0,5 × 10 <sup>6</sup>	0,5 × 10 <sup>6</sup>	0,5 × 10 <sup>6</sup>	0,5 × 10 <sup>6</sup>
Sheet group	DIN EN ISO 15527		1.2	1.2	1.2	–	–	2.1	2.1	2.1	2.1	2.1
Density	DIN EN ISO 1183-1	kg/dm <sup>3</sup>	≤ 0,94	≤ 0,94	≤ 0,94	≤ 0,96	≤ 0,96	≤ 0,96	≤ 0,96	≤ 0,96	≤ 0,96	≤ 0,96
Water absorption – saturation at 23°C	–	%	< 0,01	< 0,01	< 0,01	< 0,01	< 0,01	< 0,01	< 0,01	< 0,01	< 0,01	< 0,01
<b>Mechanical Properties<sup>1)</sup></b>												
Yield stress	DIN EN ISO 527-2	MPa	~ 20	~ 20	~ 20	~ 20	~ 20	~ 25	~ 25	~ 25	~ 25	~ 25
Breaking elongation	DIN EN ISO 527-2	%	> 300	> 300	> 300	> 280	> 200	> 500	> 500	> 500	> 500	> 500
Coefficient of elasticity (pulling test)	DIN EN ISO 527-2		> 700	> 700	> 700	> 700	> 700	> 800	> 800	> 700	> 800	> 800
Charpy impact strength – two-sided notch	DIN EN ISO 179	kJ/m <sup>2</sup>	≥ 170	≥ 170	≥ 170	≥ 80	≥ 80	≥ 25	≥ 25	≥ 25	≥ 25	≥ 25
Shore hardness D	DIN EN ISO 868	°	61–65	61–65	61–65	61–65	61–65	62–65	62–65	62–66	62–65	62–65
Indentation hardness	DIN EN ISO 2039	MPa	> 30	> 30	> 30	> 30	> 30	> 35	> 35	> 35	> 35	> 35
Sand-Slurry-Test	DIN EN ISO 15527	%	100	100	110	120	120	350	350	350	350	350
Average coefficient of friction against steel (0,25 m/s, 0,25 N/mm <sup>2</sup> )	–		0,2	0,2	0,2	0,2	0,2	0,2	0,2	0,2	0,2	0,2
Average coefficient of friction against POM (0,25 m/s, 0,25 N/mm <sup>2</sup> )	–		–	–	–	–	–	–	–	–	–	–
<b>Thermal Properties</b>												
Heat conductivity at 23°C	DIN 52612	W/(K × m)	0,4	0,4	0,4	0,4	0,4	0,4	0,4	0,4	0,4	0,4
Linear thermal coefficient of expansion (average value betw. 23 and 60 °C)	DIN EN ISO 11359-2	m/(K × m)	20 × 10 <sup>-5</sup>	20 × 10 <sup>-5</sup>	20 × 10 <sup>-5</sup>	20 × 10 <sup>-5</sup>	20 × 10 <sup>-5</sup>	20 × 10 <sup>-5</sup>	20 × 10 <sup>-5</sup>	20 × 10 <sup>-5</sup>	20 × 10 <sup>-5</sup>	20 × 10 <sup>-5</sup>
Upper service temperature in air	– Short-term service temperature <sup>2)</sup>	°C	90	90	90	90	90	90	90	90	90	90
	– Constant: for 5000 h <sup>3)</sup>	°C	80	80	80	80	80	80	80	80	80	80
Lower service temperature <sup>4)</sup>	–	°C	–200	–200	–200	–150	–150	–100	–100	–100	–100	–100
Burning behaviour as per UL94 – Sample thickness 3/6 mm	–		HB	HB	HB	HB	HB	HB	HB	HB	HB	HB
Melting temperature	DIN EN ISO 3146	°C	130–135	130–135	130–135	130–135	130–135	130–135	130–135	130–135	130–135	130–135
<b>Electrical Properties<sup>1)</sup></b>												
Electric strength	IEC 60243	kV/mm	≤ 45	≤ 45	–	≤ 45	–	≤ 45	≤ 45	–	≤ 45	≤ 45
Specific contact resistance	IEC 60093	Ω × cm	> 10 <sup>12</sup>	> 10 <sup>12</sup>	≤ 10 <sup>6</sup>	> 10 <sup>12</sup>	≤ 10 <sup>6</sup>	> 10 <sup>12</sup>	> 10 <sup>12</sup>	≤ 10 <sup>6</sup>	> 10 <sup>12</sup>	> 10 <sup>12</sup>
Specific surface resistance	IEC 60093	Ω	> 10 <sup>12</sup>	> 10 <sup>12</sup>	≤ 10 <sup>9</sup>	> 10 <sup>12</sup>	≤ 10 <sup>9</sup>	> 10 <sup>12</sup>	> 10 <sup>12</sup>	≤ 10 <sup>9</sup>	> 10 <sup>12</sup>	> 10 <sup>12</sup>
<b>Physiological Properties</b>												
Approved for use in the food industry (FDA)	–	–	Yes	Yes	Yes	No	No	Yes	Yes	Yes	Yes	Yes
Approved for use in the food industry – EU 10/2011 (only [FS] material)	–	–	Yes	Yes	Yes	No	No	Yes	Yes	Yes	Yes	Yes



NEW

Original Material "S" plus+® ESD	Original Material "S" plus+® Bright ESD	Original Material "S" plus+® LF	Original Material "S" plus+® LF ESD	Original Material "S" plus+® LFP ESD	Material "S" 8000®	Original Material "S" plus+® AB	Original Material "S" plus+® FP [FS]®	Original Material "S" plus+® GB	Original Material "S" plus+® TLS
----------------------------------	---	---------------------------------	-------------------------------------	--------------------------------------	--------------------	---------------------------------	---------------------------------------	---------------------------------	----------------------------------

PE-UHMW	PE-UHMW	PE-UHMW	PE-UHMW	PE-UHMW	PE-UHMW	PE-UHMW	PE-UHMW	PE-UHMW	PE-UHMW
black	light grey	cobalt blue	black	black	anthracite	sky-blue	light blue	light green	ruby red
5 × 10 <sup>6</sup>	9 × 10 <sup>6</sup>	9 × 10 <sup>6</sup>	9 × 10 <sup>6</sup>	9 × 10 <sup>6</sup>	9 × 10 <sup>6</sup>	5 × 10 <sup>6</sup>	9 × 10 <sup>6</sup>	9 × 10 <sup>6</sup>	9 × 10 <sup>6</sup>
1.2	1.2	1.1	1.1	1.1	1.1	1.2	1.1	1.1	1.1
≤ 0,94	≤ 0,94	≤ 0,94	≤ 0,94	≤ 0,94	≤ 0,95	≤ 0,94	≤ 0,94	≤ 0,94	≤ 0,94
< 0,01	< 0,01	< 0,01	< 0,01	< 0,01	< 0,01	< 0,01	< 0,01	< 0,01	< 0,01

~ 20	~ 20	~ 20	~ 20	~ 20	~ 20	~ 20	~ 20	~ 20	~ 20
> 300	> 300	> 250	> 220	> 300	> 200	> 300	> 200	> 250	> 200
> 700	> 200	> 700	> 700	> 700	> 600	> 700	> 600	> 600	> 600
≥ 170	≥ 170	≥ 120	≥ 120	≥ 170	≥ 170	≥ 170	≥ 100	≥ 100	≥ 140
61–65	61–65	60–63	60–63	60–62	61–64	61–65	62–64	62–65	61–64
> 30	> 30	> 25	> 25	> 30	> 35	> 30	> 35	> 35	> 30
110	120	80	80	120	80	100	100	80	80
0,2	0,2	0,1	0,1	0,2	0,2	0,2	0,2	0,2	0,2
–		~ 0,18	~ 0,18	~ 0,12	–	–	–	–	–

0,4	0,4	0,4	0,4	0,4	0,4	0,4	0,4	0,4	0,4
20 × 10 <sup>-5</sup>	20 × 10 <sup>-5</sup>	20 × 10 <sup>-5</sup>	20 × 10 <sup>-5</sup>	20 × 10 <sup>-5</sup>	17 × 10 <sup>-5</sup>	20 × 10 <sup>-5</sup>	20 × 10 <sup>-5</sup>	17 × 10 <sup>-5</sup>	20 × 10 <sup>-5</sup>
90	90	90	90	90	90	90	120	90	120
80	80	80	80	80	80	80	100	80	100
-200	-200	-200	-200	-200	-200	-200	-200	-200	-200
HB	HB	HB	HB	HB	HB	HB	HB	HB	HB
130–135	130–135	130–135	130–135	130–135	130–135	130–135	130–135	130–135	130–135

–	–	≤ 45	–	–	≤ 45	≤ 45	≤ 45	≤ 45	≤ 45
≤ 10 <sup>6</sup>	≤ 10 <sup>6</sup>	> 10 <sup>12</sup>	≤ 10 <sup>6</sup>	≤ 10 <sup>6</sup>	> 10 <sup>12</sup>	> 10 <sup>12</sup>	> 10 <sup>12</sup>	> 10 <sup>12</sup>	> 10 <sup>12</sup>
≤ 10 <sup>6</sup>	≤ 10 <sup>6</sup>	> 10 <sup>12</sup>	≤ 10 <sup>6</sup>	≤ 10 <sup>6</sup>	> 10 <sup>12</sup>	> 10 <sup>12</sup>	> 10 <sup>12</sup>	> 10 <sup>12</sup>	> 10 <sup>12</sup>

Yes	No	Yes	Yes	Yes	No	Yes	Yes	Yes	Yes
Yes	No	Yes	Yes	No	No	Yes	Yes	Yes	Yes

CHARACTERISTICS MATERIAL "S"® GROUP

TECHNICAL INFORMATION

## Characteristics

# TECHNICAL MATERIALS

Standard	Unit	Murlubric®	Murlubric® blue [FS]®	Murylon® 6 Cast
----------	------	------------	-----------------------	-----------------



Technical properties						
Code	ISO 1043-1	–	PA 6-C/Oil	PA 6-C/Oil	PA 6-C	
Material colour	–	–	black	blue	natural/black	
Density	ISO 1183-1	g/cm <sup>3</sup>	1,135	1,14	1,15	
Water absorption	– after 24/96 h storage in water at 23°C	ISO 62	%	0,66/1,24	0,66/1,24	0,65/1,22
	– saturation in standard atmosphere of 23°C/50% RH	–	%	2	1,8	2,2
	– saturation in water at 23°C	–	%	6,3	5,5	6,5

Mechanical Properties <sup>1)</sup>			+	++	+	++	+	++
Yield stress	ISO 527-1/-2	MPa	72/-	45/-	80/-	55/-	86/-	55/-
Breaking elongation	ISO 527-1/-2	%	25	> 50	25	> 50	25	> 50
Coefficient of elasticity (pulling test)	ISO 527-1/-2	MPa	3000	1450	2800	1700	3600	1750
Pressure test – compression strength at 1/2/5% nominal compression	ISO 604	MPa	22/43/79		22/43/79		34/63/93	
Time-dependent creep tensile test, stress leading to an elongation of 1% after 1000h	ISO 899-1	MPa	18	8	18	8	22	10
Charpy impact strength	ISO 179-1/1eU	kJ/m <sup>2</sup>	50		o. B.		o. B.	
Notch impact toughness (Charpy)	ISO 179-1/1eA	kJ/m <sup>2</sup>	4		> 5		3	
Indentation hardness	ISO 2039-1	N/mm <sup>2</sup>	145		150		168	
Rockwell hardness	ISO 2039-2	–	M82		M82		M88	
Coefficient of sliding friction (dry)	–	–	0,18		0,18		0,3	
Sand Slurry test	–	µm/km	0,05		0,05		0,12	

Thermal Properties								
Melting temperature	ISO 11357-1/-3	°C	215		220		215	
Glass transition temperature	ISO 11357-1/-2	°C	50		50		50	
Heat conductivity at 23°C	–	W/(K x m)	0,28		0,23		0,9	
Linear thermal coefficient of expansion	– average value between 23 and 60°C	m/(K x m)	80 × 10 <sup>-6</sup>		80 × 10 <sup>-6</sup>		80 × 10 <sup>-6</sup>	
	– average value between 23 and 100°C	m/(K x m)	90 × 10 <sup>-6</sup>		90 × 10 <sup>-6</sup>		90 × 10 <sup>-6</sup>	
Upper service temperature in air	– Short-term service temperature <sup>2)</sup>	°C	165		160		170	
	– Constant: for 5000/20000h <sup>3)</sup>	°C	105/90		105/90		105/90	
Lower service temperature <sup>4)</sup>	–	°C	-20		-30		-30	
Burning behaviour as per UL94 – Sample thickness 3/6 mm	–	–	HB/HB		HB/HB		HB/HB	

Electrical Properties <sup>1)</sup>			+	++	+	++	+	++
Electric strength <sup>5)</sup>	IEC 69243-1	kV/mm	22	14	22	14	25	17
Specific contact resistance	IEC 60093	Ohm x cm	> 10 <sup>14</sup>	> 10 <sup>12</sup>	> 10 <sup>14</sup>	> 10 <sup>12</sup>	> 10 <sup>14</sup>	> 10 <sup>12</sup>
Specific surface resistance	IEC 60093	Ohm	> 10 <sup>13</sup>	> 10 <sup>12</sup>	> 10 <sup>13</sup>	> 10 <sup>12</sup>	> 10 <sup>13</sup>	> 10 <sup>12</sup>
Relative permittivity	– at 100 Hz	IEC 60250	3,5	6,5	3,5	6,5	3,6	6,6
	– at 1 MHz	IEC 60250	3,1	3,6	3,1	3,6	3,2	3,7
Dielectric loss factor	– at 100 Hz	IEC 60250	0,015	0,15	0,015	0,15	0,012	0,14
	– at 1 MHz	IEC 60250	0,016	0,05	0,016	0,05	0,016	0,05

Physiological Properties							
Approved for use in the food industry (FDA)	–	–	No	Yes		Yes / Yes	
Approved for use in the food industry – EU 10/2011 (only [FS] material)	–	–	No	Yes		No / No	

Murdopol®	Murylon® B	Murylon® A	Murylon® A GF	Murytal® C	Murytal® C blue [FS]®	Murytal® H	Murytal® ESD	Murylat®	Murylat® SP
-----------	------------	------------	---------------	------------	-----------------------	------------	--------------	----------	-------------

PA 12-C	PA 6	PA 66	PA 66-GF	POM-C	POM-C	POM-H	POM-C	PETP	PETP-SP
natural	natural/black	natural/black	black	natural/black	ultramarine blue	natural/black	black	natural/black	light grey
1,03	1,14	1,14	1,29	1,41	1,41	1,43	1,41	1,39	1,44
-	1,28/2,5	0,6/1,13	0,39/0,74	0,24/0,45	0,05/0,1	0,21/0,43	0,05/0,2	0,07/0,16	0,06/0,13
0,9	2,6	2,4	1,7	0,2	0,1	0,2	0,1	0,25	0,23
1,4	9	8	5,5	0,8	0,7	0,8	0,7	0,5	0,47

+	++	+	++	+	++	+	++						
55/-	80/-	45/-	90/-	55/-	-/85	-/-	66/-	67/-	78/-	42/-	90/-	76/-	
>200	>50	>100	50	>100	5	-	50	32	50	11	15	5	
2000	3300	1425	3550	1700	5000	2700	2800	2800	3300	1800	3500	3300	
-	24/46/80		24/49/92		43/77/112		23/40/72	23/40/72	22/40/75	23/40/72	26/51/103	24/47/95	
-	18	7	20	8	-	-	-	-	15	-	26	23	
o. B.	o. B.		o. B.		50		o. B.	o. B.	200	74	50	30	
15	5,5		4,5		6		8	9	10	-	2	2,5	
172	150		160		165		140	158	160	96	170	160	
-	M85		M88		M76		M84	M84	M88	M84	M96	M94	
0,35	0,35		0,3		0,35		0,3	0,3	0,3	0,34	0,3	0,18	
0,8	0,23		0,1		0,28		8,9	8,9	8,9	-	-	0,05	

180	220	260	260	165	166	180	169	245	245
-	50	60	60	-50	-60	-60	-60	70	70
0,23	0,28	0,28	0,3	0,31	0,31	0,31	0,46	0,29	0,29
110 × 10 <sup>-6</sup>	90 × 10 <sup>-6</sup>	80 × 10 <sup>-6</sup>	50 × 10 <sup>-6</sup>	110 × 10 <sup>-6</sup>	110 × 10 <sup>-6</sup>	95 × 10 <sup>-6</sup>	110 × 10 <sup>-6</sup>	60 × 10 <sup>-6</sup>	65 × 10 <sup>-6</sup>
125 × 10 <sup>-6</sup>	105 × 10 <sup>-6</sup>	95 × 10 <sup>-6</sup>	60 × 10 <sup>-6</sup>	125 × 10 <sup>-6</sup>	125 × 10 <sup>-6</sup>	110 × 10 <sup>-6</sup>	125 × 10 <sup>-6</sup>	80 × 10 <sup>-6</sup>	85 × 10 <sup>-6</sup>
150	160	180	200	140	140	150	140	160	160
120/-	85/70	95/80	120/110	115/100	115/100	105/90	115/100	115/100	115/100
-60	-40	-30	-20	-50	-50	-50	-50	-20	-20
HB/-	HB/HB	HB/HB	HB/HB	HB/HB	HB/HB	HB/HB	HB/HB	HB/HB	HB/HB

+	++	+	++	+	++	+	++						
50	20	25	16	27	18	27	18	20	20	20	-	22	21
>10 <sup>14</sup>	>10 <sup>12</sup>	>10 <sup>14</sup>	>10 <sup>12</sup>	>10 <sup>14</sup>	>10 <sup>12</sup>	>10 <sup>14</sup>	>10 <sup>12</sup>	>10 <sup>14</sup>	>10 <sup>14</sup>	>10 <sup>14</sup>	<10 <sup>4</sup>	>10 <sup>14</sup>	>10 <sup>14</sup>
>10 <sup>13</sup>	>10 <sup>12</sup>	>10 <sup>13</sup>	>10 <sup>12</sup>	>10 <sup>13</sup>	>10 <sup>12</sup>	>10 <sup>13</sup>	>10 <sup>12</sup>	>10 <sup>13</sup>	>10 <sup>13</sup>	>10 <sup>13</sup>	<10 <sup>4</sup>	>10 <sup>13</sup>	>10 <sup>13</sup>
3,5	-	3,9	7,4	3,8	7,4	3,9	6,9	3,8	3,8	3,8	-	3,4	3,4
-	-	3,3	3,8	3,3	3,8	3,6	3,9	3,8	3,8	3,8	-	3,2	3,2
0,038	-	0,019	0,13	0,013	0,13	0,012	0,19	0,003	0,003	0,003	-	0,001	0,001
-	-	0,021	0,06	0,02	0,06	0,014	0,04	0,008	0,008	0,008	-	0,014	0,14

Yes	Yes / Yes	Yes / Yes	No	Yes / Yes	Yes	No / No	No	Yes / Yes	Yes
No	Yes / No	Yes / No	No	Yes / No	Yes	No / No	No	Yes / Yes	Yes

## Characteristics

# HIGH-PERFORMANCE MATERIALS

Standard	Unit	Murylon® HT	Murinyl®
----------	------	-------------	----------



Technical properties					
Code		ISO 1043-1	–	PA 46	PVDF
Material colour		–	–	auburn	natural
Density		ISO 1183-1	g/cm <sup>3</sup>	1,19	1,79
Water absorption	– after 24/96 h storage in water at 23°C	ISO 62	%	1,3/2,6	–
	– saturation in standard atmosphere of 23°C/50% RH	–	%	2,8	0,01
	– saturation in water at 23°C	–	%	9,5	0,05

Mechanical Properties <sup>1)</sup>						
				+	++	
Yield stress	ISO 527-1/-2	MPa		105/-	55/-	62/-
Breaking elongation	ISO 527-1/-2	%		25	>50	17
Coefficient of elasticity (pulling test)	ISO 527-1/-2	MPa		3400	1350	2200
Pressure test – compression strength at 1/2/5% nominal compression	ISO 604	MPa		31/60/102		17/32/-
Time-dependent creep tensile test, stress leading to an elongation of 1% after 1000h	ISO 899-1	MPa		–	–	10
Charpy impact strength	ISO 179-1/1eU	kJ/m <sup>2</sup>		o. B.		150
Notch impact toughness (Charpy)	ISO 179-1/1eA	kJ/m <sup>2</sup>		8		–
Indentation hardness	ISO 2039-1	N/mm <sup>2</sup>		165		129
Rockwell hardness	ISO 2039-2	–		M92		–
Coefficient of sliding friction (dry)	–	–		0,34		0,35
Sand Slurry test	–	µm/km		–		21

Thermal Properties						
Melting temperature	ISO 11357-1/-3	°C		290		171
Glass transition temperature	ISO 11357-1/-2	°C		80		–
Heat conductivity at 23°C	–	W/(K × m)		0,3		0,25
Linear thermal coefficient of expansion	– average value between 23 and 60°C	–	m/(K × m)	80 × 10 <sup>-6</sup>		130 × 10 <sup>-6</sup>
	– average value between 23 and 100°C	–	m/(K × m)	90 × 10 <sup>-6</sup>		150 × 10 <sup>-6</sup>
	– average value above 150°C	–	m/(K × m)	–		–
Upper service temperature in air	– Short-term service temperature <sup>2)</sup>	–	°C	200		160
	– Constant: for 5000/20000h <sup>3)</sup>	–	°C	150/130		-/150
Lower service temperature <sup>4)</sup>	–	°C		-40		-50
Burning behaviour as per UL94 – Sample thickness 3/6 mm	–	–		HB/HB		V0/V0

Electrical Properties <sup>1)</sup>						
				+	++	
Electric strength <sup>5)</sup>	IEC 69243-1	kV/mm		25	15	18
Specific contact resistance	IEC 60093	Ohm × cm		>10 <sup>14</sup>	>10 <sup>12</sup>	>10 <sup>14</sup>
Specific surface resistance	IEC 60093	Ohm		>10 <sup>13</sup>	>10 <sup>12</sup>	>10 <sup>13</sup>
Relative permittivity	– at 100 Hz	IEC 60250	–	3,8	7,4	7,4
	– at 1 MHz	IEC 60250	–	3,4	3,8	6
Dielectric loss factor	– at 100 Hz	IEC 60250	–	0,009	0,13	0,025
	– at 1 MHz	IEC 60250	–	0,019	0,06	0,165

Physiological Properties						
Approved for use in the food industry (FDA)	–	–		Nein		Ja
Approved for use in the food industry – EU 10/2011 (only [FS] material)	–	–		Nein		Ja

Murflor®	Murflor® + Carbon (25%)	Murflor® + Bronze (60%)	Murflor® + Glass (25%)	Murinit® SP	Murpec®	Murpec® SP
----------	-------------------------	-------------------------	------------------------	-------------	---------	------------



PTFE	PTFE-C	PTFE-CuSn	PTFE-GF	PPS-SP	PEEK	PEEK-SP
natural	black	bronze	natural	dark blue	natural/black	black
2,18	2,1	3,88	2,23	1,42	1,31	1,45
-	-	-	-	0,01/0,02	0,06/0,12	0,05/0,11
-	-	-	-	0,05	0,2	0,16
-	-	-	-	0,2	0,45	0,35

26/-	15/-	14/-	16/-	-/78	115/-	-/78
280	100	120	160	3,5	17	3
750	-	-	-	4000	4300	5900
4/-/-	10/-/-	10,5/-/-	7/-/-	33/65/105	38/75/140	46/80/120
-	-	-	-	-	-	-
-	-	-	-	25	o. B.	25
154	83	104	116	4	3,5	3
-	-	-	-	160	210	215
-	-	-	-	M82	M105	M85
0,08	0,12	0,14	0,15	0,2	0,2	0,15
21	1	0,5	-	0,1	0,3	0,05

321	330	330	330	280	340	340
127	127	127	127	100	143	143
0,23	0,58	0,69	0,45	0,3	0,25	0,78
-	-	-	-	$50 \times 10^{-6}$	$50 \times 10^{-6}$	$35 \times 10^{-6}$
$160 \times 10^{-6}$	$95 \times 10^{-6}$	$90 \times 10^{-6}$	$100 \times 10^{-6}$	$60 \times 10^{-6}$	$55 \times 10^{-6}$	$40 \times 10^{-6}$
-	-	-	-	$100 \times 10^{-6}$	$130 \times 10^{-6}$	$85 \times 10^{-6}$
300	300	300	300	260	310	310
-/260	-/260	-/260	-/260	-/220	-/250	-/250
-200	-200	-200	-200	-20	-50	-20
V0/V0	V0/V0	V0/V0	V0/V0	V0/V0	V0/V0	V0/V0

20	-	-	13	24	24	-
$>10^{17}$	-	-	$>10^{16}$	$>10^{14}$	$>10^{14}$	-
$>10^{15}$	-	-	$>10^{16}$	$>10^{13}$	$>10^{13}$	-
2	-	-	2,85	3,3	3,2	-
2,1	-	-	-	3,3	3,2	-
0,0003	-	-	0,0029	0,003	0,001	-
0,0001	-	-	-	0,003	0,002	-

Ja	Nein	Nein	Nein	Ja	Ja / Ja	Nein
Ja	Nein	Nein	Nein	Ja	Ja / Nein	Nein



# CONSTANT SERVICE TEMPERATURES IN °C (for 5.000h) \*(for 20.000h)

## Comparison of Materials

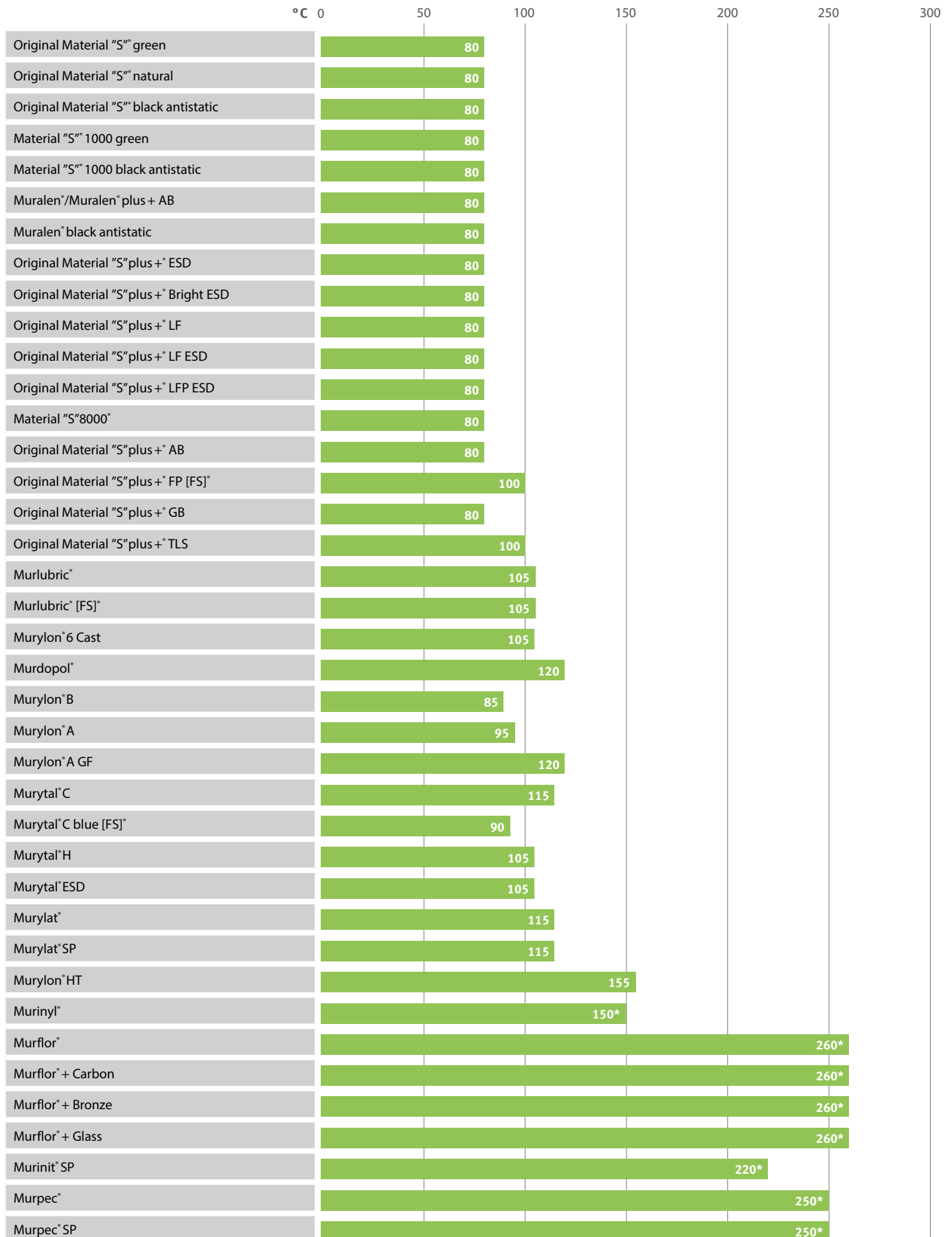





# SLIDING FRICTION COEFFICIENT

## Comparison of Materials

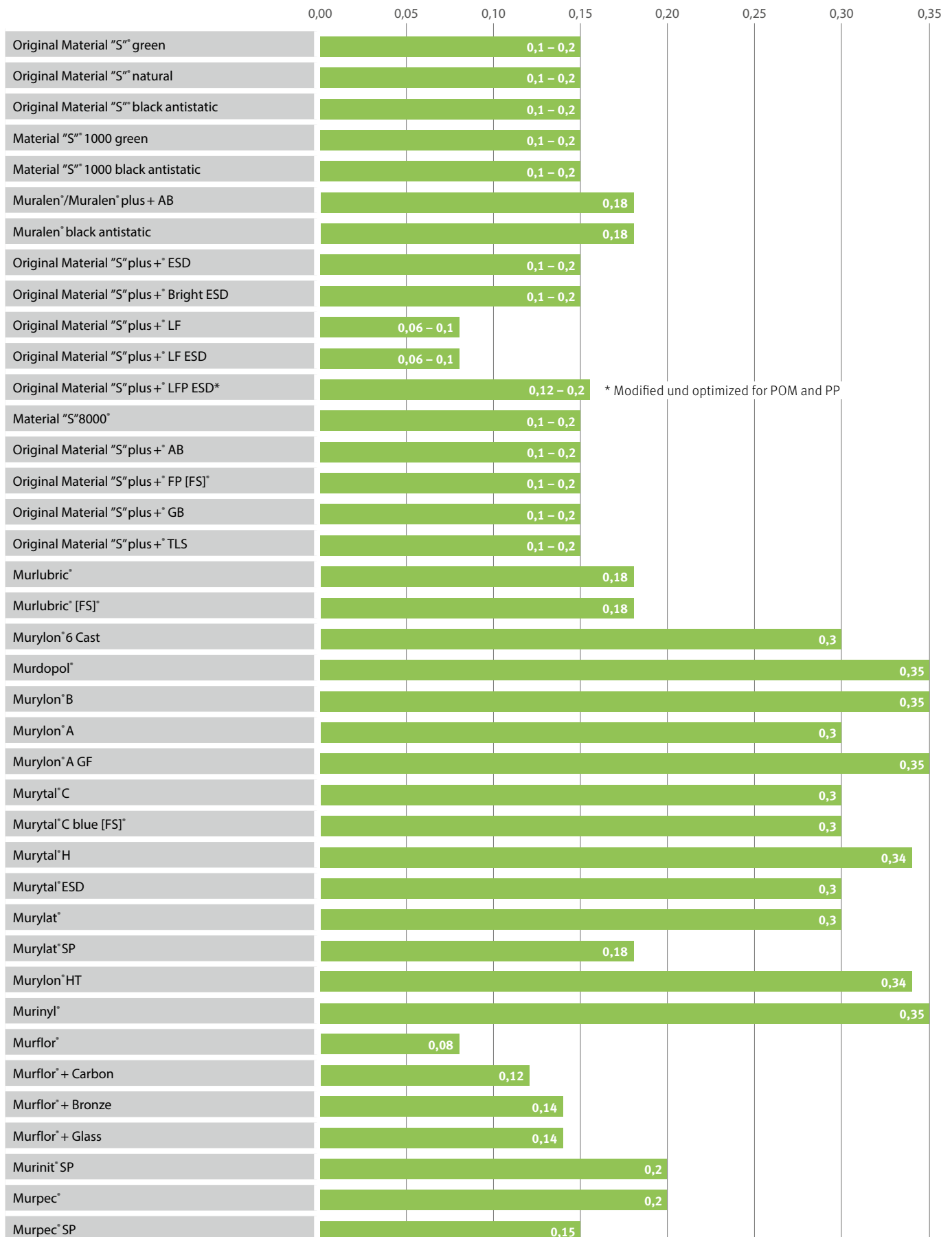



# WEAR RESISTANCE

## Comparison of Materials

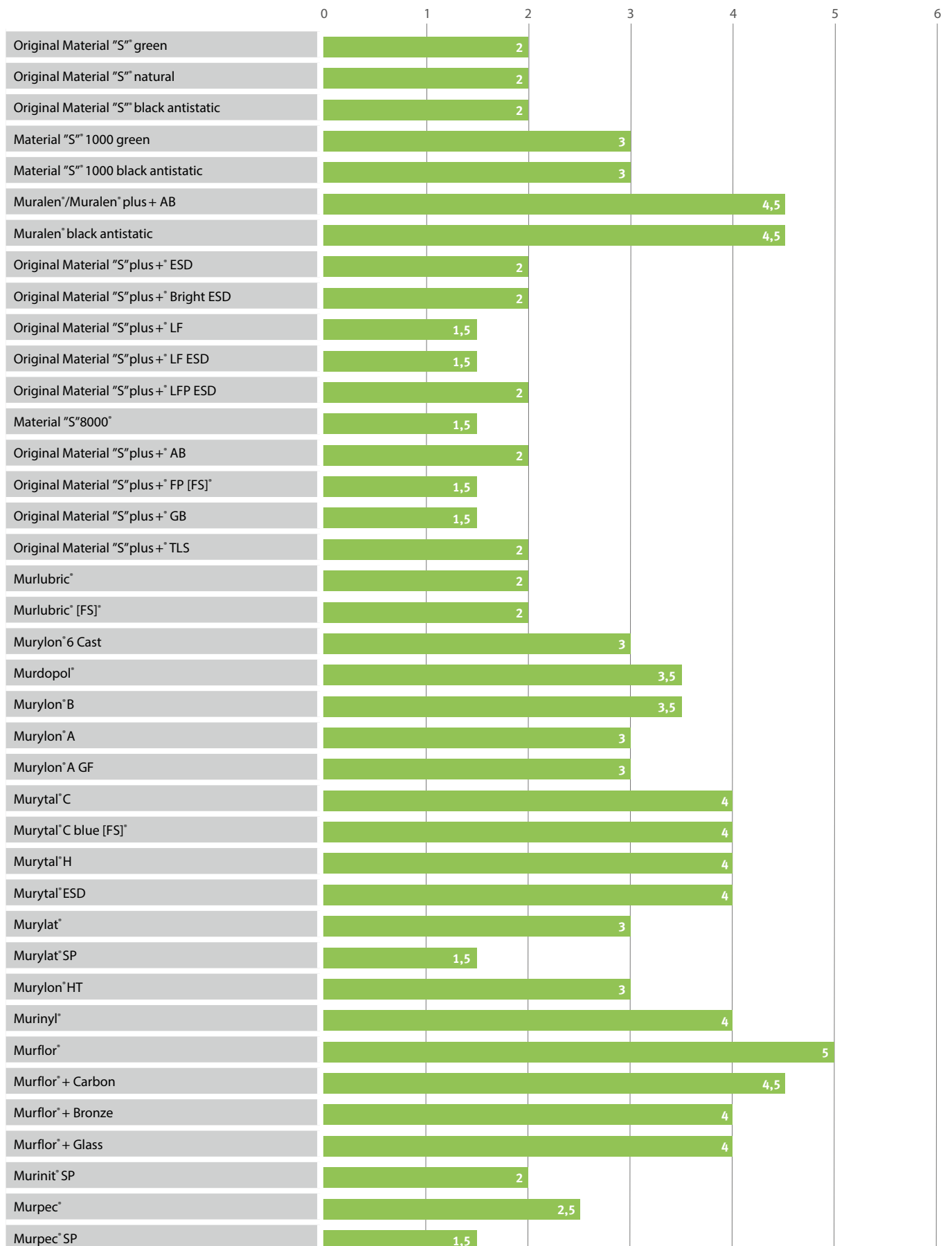

1 = excellent, 6 = less good



# UV RESISTANCE

## Comparison of Materials

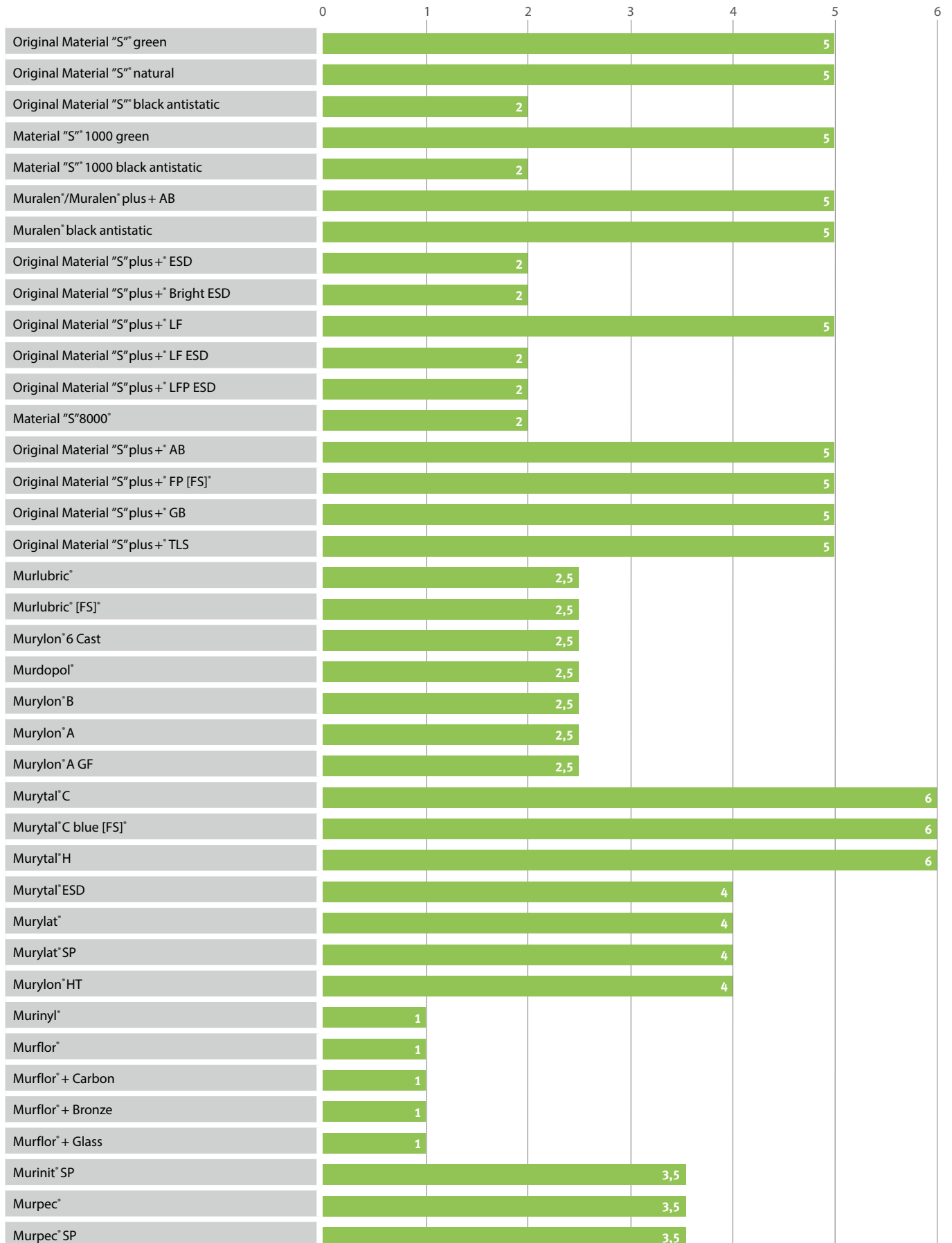

1 = excellent, 6 = less good



# COEFFICIENT OF EXPANSION

(between 23 and 60°C)

\*(between 23 and 100°C)

## Comparison of Materials

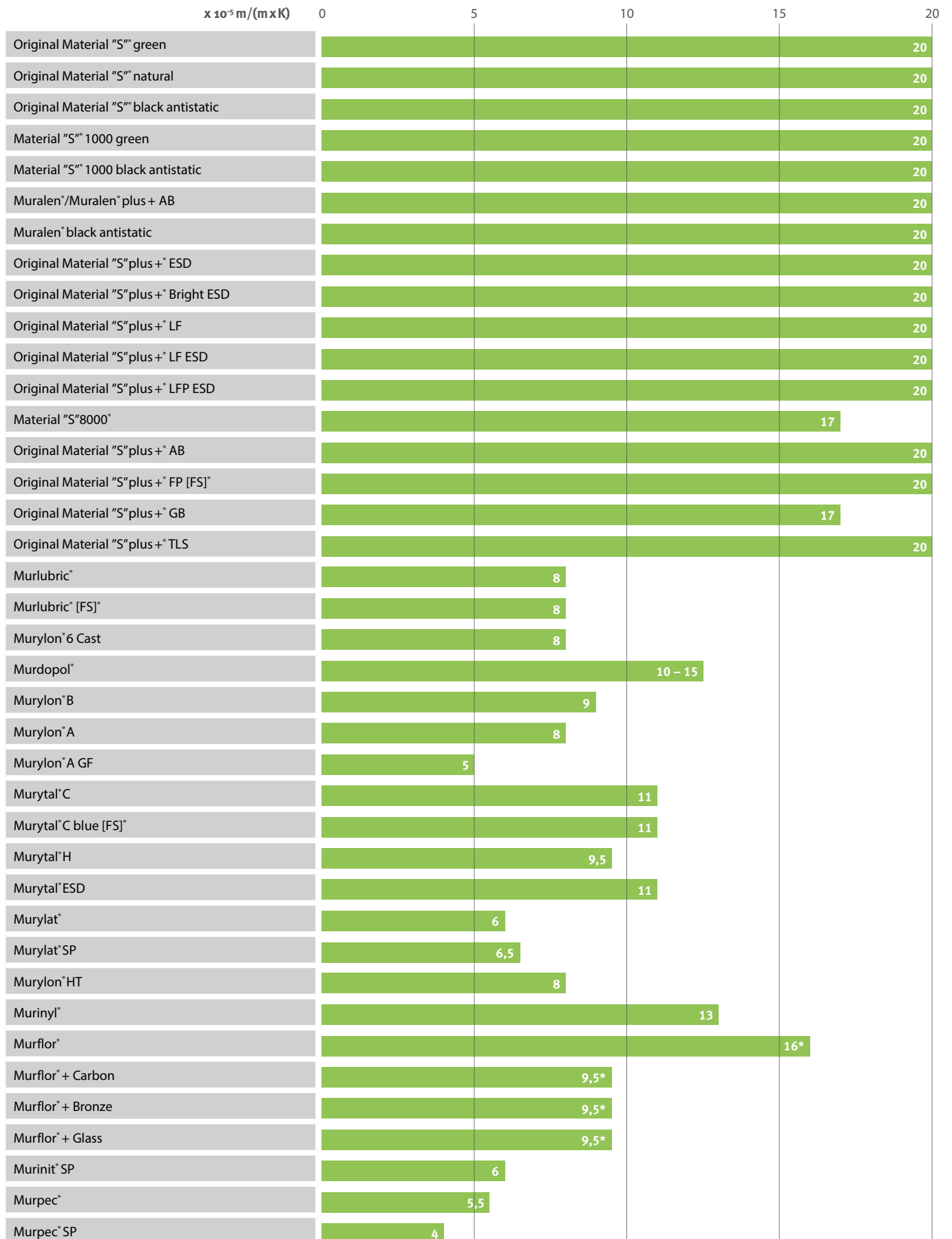

# E COEFFICIENT OF ELASTICITY

## Comparison of Materials

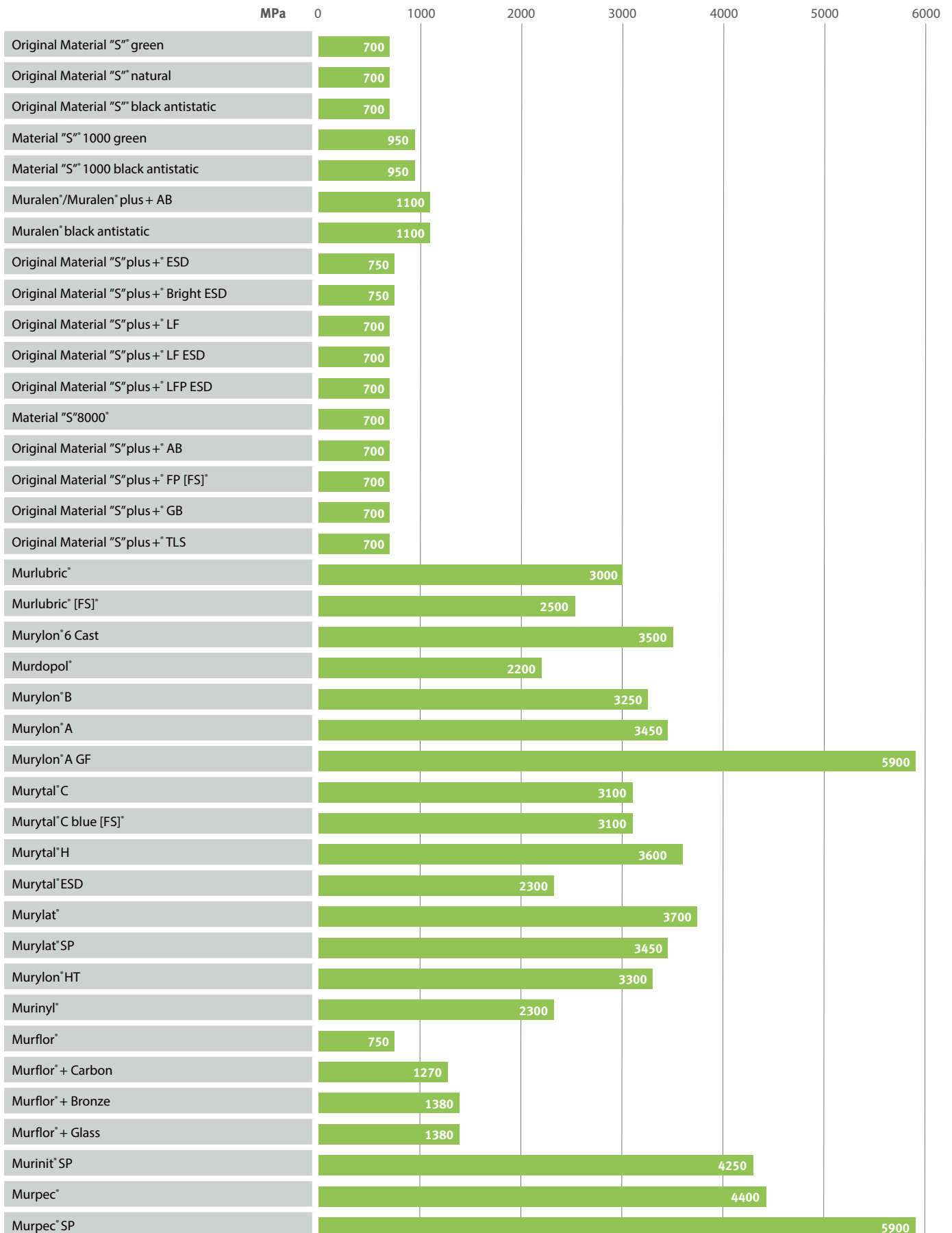

# INFORMATION ON THE BEHAVIOUR OF PLASTICS

Plastics are known for their light weight and many uses – thanks to the incorporation of additives. However, plastics often respond differently to external factors than the much more familiar material – metal.

## 1. Thermal expansion

The thermal expansion of plastics, in particular, is greater than that of metals! In the event of heat or cold, their volume on all sides of the component changes. Even when the reference temperature of 23 degrees is reached again, the plastic can retain a certain elongation or reduction, leading to dimensional differences (given by linear thermal expansion coefficients  $\alpha$ ).

## 2. Moisture absorption

The air humidity of the surrounding plays a key role particularly with polyamides (PA). When stored in water, for example, or when used at high levels of humidity, they can absorb up to 10% water. The finished parts swell up and cause dimensional differences.

## 3. Release of internal stresses

Plastic semi-finished products are produced at high pressure and at high temperature, causing high internal stresses when the parts cool down. These stresses are released in subsequent cutting, particularly with large changes of cross-section. Cutting or machining pre-treatment and tempering in a thermal furnace can help but does not fully eliminate all stresses.

## 4. Flow behaviour

Please note! Plastic can start to „flow“ under pressure or tensile load.

## 5. Machining

The elasticity of plastics is much greater than that of metal. However, there can be dimensional differences here too, dependent on the tool used.

### Rule of thumb:

As a rule of thumb, a manufacturing tolerance of 0.1 % to 0.2 % of the nominal dimension (for nominal dimensions above 50 mm) can be maintained.

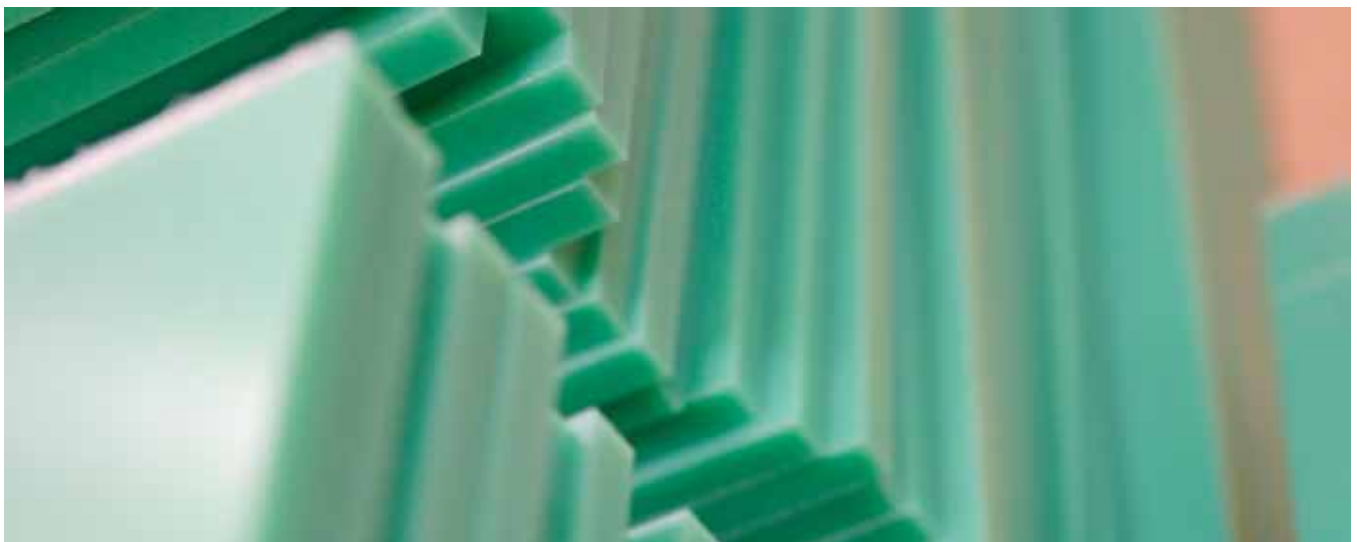



# INFORMATION ON THE BEHAVIOUR OF PLASTICS

## EXAMPLE OF A THERMAL EXPANSION CALCULATION

**FORMULA:**  $\Delta L = L \times \alpha_k \times \Delta T$

$\Delta L$  = Length change

L = Initial length

$\alpha_k$  = Coefficient of linear expansion

$\Delta T$  = Temperature difference in K with prefix

### Example

Profile made of Original Material "S"<sup>®</sup> green 1000 mm long, produced at 20°C transported at summer temperatures of 40°C

### Calculation of linear expansion::

2 mm per 10°C increase in temperature = 1004 mm

## PLEASE NOTE:

1. INCOMING GOODS INSPECTION/QUALITY ASSURANCE  
Ideally you should check Murtfeldt components at an ambient temperature of 23°C after a storage period of 24 hours.
2. DESIGN  
Please take into account the thermal expansion of the plastics in the design of components. Any expected subsequent dimensional changes will therefore not impair the intended function of the machine part.

**Phone 0049 231 20609-0**

Should you have any questions, our application engineers will be happy to advise you free of charge.

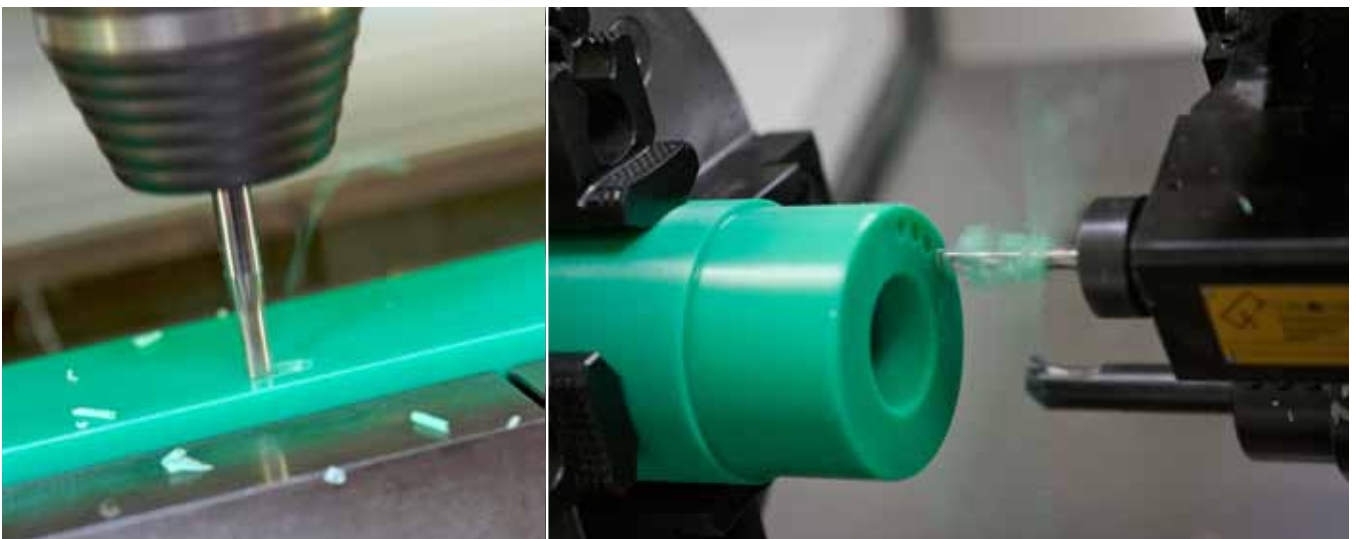

## USEFUL INFORMATION

### Order example for plastic guides

Original Material "S"<sup>®</sup> green, Type CT for chain 06B-1

Article no. **2 2 1 2 1 0 0 1 5**

Material "S"<sup>®</sup>1000 green, Type CT for chain 06B-1

Article no. **2 2 1 2 2 0 0 1 5**

### The C profile must be ordered separately:

C3, galvanized steel, length of 2000 mm

Article no. **3 5 1 0 2 0 0 0 3**

C3, stainless steel, length of 2000 mm

Article no. **3 5 1 0 2 0 1 0 3**

### Electricity: Units

Term	Unit	Symbol	Derivation from SI units
Current	Ampere	A	SI base unit
Charge	Coulomb	C	1C = 1As
Voltage	Volt	V	1V = 1W/A = 1m <sup>2</sup> kg s <sup>-3</sup> A <sup>-1</sup>
Power	Watt	W	1W = 1VA = 1m <sup>2</sup> kg s <sup>-3</sup>
Resistance	Ohm	Ω	1Ω = 1V/A = 1m <sup>2</sup> kg s <sup>-3</sup> A <sup>-2</sup>
Capacitance	Farad	F	1F = 1C/V = 1m <sup>-2</sup> kg <sup>-1</sup> s <sup>4</sup> A <sup>2</sup>
Electrical conductance	Siemens	S	1S = 1A/V = 1m <sup>-2</sup> kg <sup>-1</sup> s <sup>3</sup> A <sup>2</sup>

### Length conversion table

1 inch (in)	= 2.54cm	1 cm	= 0.3937in.
1 mil = 1/1000 in.	= 2.54 × 10 <sup>-3</sup> cm	1 mm	= 39.37mil
1 microinch	= 2.54 × 10 <sup>-6</sup> cm	1 Mikrometre	= 39.37microinch
1 foot (ft.) = 12 in.	= 30.48cm	1 cm	= 0.0328ft.
1 yard = 3 ft.	= 91.44cm	1 m	= 1.0936yd.
1 rod (rd.) = 5.5 yd.	= 5.0292m	1 m	= 0.1988rd.
1 mile (statute)	= 1.60934km	1 km	= 0.6214mile (st.)
1 mile (nautical)	= 1.853km	1 km	= 0.54mile (naut.)

### Area conversion table

1square in. (sq.in.)	= 6.4516cm <sup>2</sup>	cm <sup>2</sup>	= 0.1550sq.in.
1sq.ft. = 144 in. <sup>2</sup>	= 0.0929m <sup>2</sup>	m <sup>2</sup>	= 10.7639sq.ft.
1sq.yd. = 9 ft. <sup>2</sup>	= 0.8361m <sup>2</sup>	m <sup>2</sup>	= 1.19599sq.yd.
1sq.rd	= 25.293m <sup>2</sup>	m <sup>2</sup>	= 0.0395sq.rd.
1acre (A) = 4840sq.yd.	= 0.404687ha	a = 0.0247 acre	= 119.6sq.yd.
1sq.mile	= 2.58999km <sup>2</sup>	km <sup>2</sup>	= 0.387sq.mile
1barn	= 1 × 10 <sup>-28</sup> cm <sup>2</sup>		

### Conversion factors for units of pressure

	Pa	bar	N/mm <sup>2</sup>	kp/m <sup>2</sup>	kp/cm <sup>2</sup> (at)	atm	Torr
1 Pa (N/m <sup>2</sup> ) =	1	10 <sup>-5</sup>	10 <sup>-6</sup>	0,102	0.102 *10 <sup>-4</sup>	0.987 *10 <sup>-5</sup>	0.0075
1 bar (daN/cm <sup>2</sup> ) =	100000	1	0,1	10200	1.02	0.987	750
1 N/mm <sup>2</sup> =	10 <sup>6</sup>	10	1	1.02 *10 <sup>5</sup>	10.2	9.87	7500
1 kp/m <sup>2</sup> =	9.81	9.81 *10 <sup>-5</sup>	9,81 *10 <sup>-6</sup>	1	10 <sup>-4</sup>	0.968 *10 <sup>-4</sup>	0.0736
1 kp/cm <sup>2</sup> (1 at) =	98100	0.981	0.0981	10000	1	0.968	736
1 atm (760 Torr) =	101325	1,013	0.1013	10330	1.033	1	760
1 Torr =	133	0.00133	1.33 *10 <sup>-4</sup>	13.6	0.00132	0.00132	1

# PICTOGRAM LEGEND

Profiles – standard		Variable – optional possibilities
<b>Original Material "S"® green</b>	<b>Length of plastic guide and steel C profile in mm</b>	<b>Ex stock in Material "S"® 1000 green</b>
<b>Original Material "S"® black antistatic</b>	<b>Standard design in galvanized steel</b>	<b>In intermediate dimensions and other materials if required</b>
<b>Medium tolerances on plastic profile section</b> as per DIN ISO 2768, tolerance class m	<b>Only suitable for outer facing connecting link</b>	<b>6,000 mm steel profile length possible</b>
<b>Length tolerance</b> Plastic guide +0/+7mm Steel C profile +0/+40mm	<b>Profile section for two-part design</b>	<b>Available ex stock in 1.4301 (stainless steel)</b>
	<b>For use in explosion hazard areas</b> (manufacturer's declaration)	<b>Profile section for two-part design</b>

Features and properties of tensioning system		Profile symbols for selection tables
<b>One pre-tensioned compression spring</b> Tension distance specification in mm	<b>Steel housing</b>	<b>Arc segment profile</b>
<b>Two pre-tensioned compression springs</b> Tension distance specification in mm	<b>Plastic housing</b>	<b>Block profile</b>
<b>Three pre-tensioned compression springs</b> Tension distance specification in mm	<b>Track profile</b> for all large chains	<b>Return profile</b>
<b>Further adjustment possible:</b> Adjustment range in mm once original tension distance has been used	<b>U Profile</b> for chains up to specified overall width in mm	<b>Semi-circular profile</b>
		<b>Roller/sprocket</b>





Heßlingsweg 14 – 16  
D-44309 Dortmund  
Phone +49 231 20609-0  
Fax +49 231 251021  
[www.murtfeldt.com](http://www.murtfeldt.com)